



UL 1598

**Underwriters Laboratories Inc.**  
**Standard for Safety**

Luminaires





UL Standard for Safety for Luminaires, UL 1598

Third Edition, Dated September 17, 2008

**Summary of Topics**

***These revisions for UL 1598 are being issued to correct the edition number of the NMX-J-307/1-ANCE to the second edition. These revisions are considered to be non-substantive and not subject to UL's STP process.***

Text that has been changed in any manner or impacted by UL's electronic publishing system is marked with a vertical line in the margin.

All rights reserved. No part of this publication may be reproduced, stored in a retrieval system, or transmitted in any form by any means, electronic, mechanical photocopying, recording, or otherwise without prior permission of UL.

UL provides this Standard "as is" without warranty of any kind, either expressed or implied, including but not limited to, the implied warranties of merchantability or fitness for any purpose.

In no event will UL be liable for any special, incidental, consequential, indirect or similar damages, including loss of profits, lost savings, loss of data, or any other damages arising out of the use of or the inability to use this Standard, even if UL or an authorized UL representative has been advised of the possibility of such damage. In no event shall UL's liability for any damage ever exceed the price paid for this Standard, regardless of the form of the claim.

Users of the electronic versions of UL's Standards for Safety agree to defend, indemnify, and hold UL harmless from and against any loss, expense, liability, damage, claim, or judgment (including reasonable attorney's fees) resulting from any error or deviation introduced while purchaser is storing an electronic Standard on the purchaser's computer system.

The requirements in this Standard are now in effect, except for those paragraphs, sections, tables, figures, and/or other elements of the Standard having future effective dates as indicated in the preface. The prior text for requirements that have been revised and that have a future effective date are located after the Standard, and are preceded by a "SUPERSEDED REQUIREMENTS" notice.

The following table lists the future effective dates with the corresponding reference.

---

<b>Future Effective Date</b>	<b>References</b>
September 17, 2010	Clauses 5.10.12, 6.13.2.5, 6.14.2.9, 8.8, 9.3.1, 9.4.1.1, 9.4.2.1, 12.2.4.6, 18.6, 16.38, and 16.39.



Association of Standardization and Certification  
NMX-J-307/1-ANCE  
Second Edition



Canadian Standards Association  
C22.2 No. 250.0-08  
Third Edition



Underwriters Laboratories Inc.  
UL 1598  
Third Edition

## Luminaires

September 17, 2008

(Title Page Reprinted: January 11, 2010)



ANSI/UL 1598-2008

## **Commitment for Amendments**

This Standard is issued jointly by the Association of Standardization and Certification (ANCE), the Canadian Standards Association (CSA), and Underwriters Laboratories Inc. (UL). Comments or proposals for revisions on any part of the standard may be submitted to ANCE, CSA, or UL at any time. Revisions to this standard will be made only after processing according to the standards development procedures of ANCE, CSA, and UL. CSA and UL will issue revisions to this standard by means of a new edition or revised or additional pages bearing their date of issue. ANCE will incorporate the same revisions into a new edition of the standard bearing the same date of issue as the CSA and UL pages.

---

## **Copyright © 2008 ANCE**

Rights reserved in favor of ANCE

---

**ISBN 978-1-55436-559-3**

**© 2008**

**Canadian Standards Association**

All rights reserved. No part of this publication may be reproduced in any form whatsoever without the prior permission of the publisher.

To purchase CSA Standards and related publications, visit CSA's Online Store at **[www.ShopCSA.ca](http://www.ShopCSA.ca)** or call toll-free 1-800-463-6727 or 416-747-4044.

---

## **Copyright © 2010 Underwriters Laboratories Inc.**

UL's Standards for Safety are copyrighted by UL. Neither a printed nor electronic copy of a Standard should be altered in any way. All of UL's Standards and all copyrights, ownerships, and rights regarding those Standards shall remain the sole and exclusive property of UL.

This ANSI/UL Standard for Safety consists of the Third Edition including revisions through January 11, 2010.

The most recent designation of ANSI/UL 1598 as an American National Standard (ANSI) occurred on September 17, 2008. ANSI approval for a standard does not include the Cover Page, Transmittal Pages, Title Page (front and back), or the Preface.

Comments or proposals for revisions on any part of the Standard may be submitted to UL at any time. Proposals should be submitted via a Proposal Request in UL's On-Line Collaborative Standards Development System (CSDS) at <http://csds.ul.com>.

To purchase UL Standards, visit Comm 2000 at [http://www.comm-2000.com/help/how\\_to\\_order.aspx](http://www.comm-2000.com/help/how_to_order.aspx) or call toll-free 1-888-853-3503.

---

## CONTENTS

Preface .....	8
1 Scope .....	10
2 Reference publications .....	10
3 Definitions .....	13
4 General requirements .....	18
4.1 Components .....	18
4.2 Application of requirements .....	19
4.3 Units of measurement .....	19
5 Mechanical construction .....	29
5.1 General .....	29
5.2 Assembly and packaging .....	29
5.3 Enclosures .....	30
5.4 Barriers .....	30
5.5 Metal thickness for enclosures .....	30
5.6 Corrosion protection .....	32
5.7 Polymeric materials .....	33
5.8 Baffles .....	35
5.9 Conduit knockouts and twistouts .....	36
5.10 Mechanical joints and fastenings .....	36
5.11 Means of mounting .....	37
5.12 Movable joints .....	37
5.13 Raceway tubing .....	37
5.14 Conductor protection .....	38
5.15 Strain relief .....	38
5.16 Glass .....	39
5.17 Glass support .....	40
5.18 Thermal insulation .....	41
5.19 Continuous row mounting .....	41
5.20 Raceways .....	42
6 Electrical construction .....	42
6.1 General .....	42
6.2 Wiring devices .....	42
6.3 Lampholders .....	43
6.4 Switches .....	43
6.5 Receptacles .....	44
6.6 Fuses and fuseholders .....	45
6.7 Ballasts and transformers .....	45
6.8 Capacitors .....	49
6.9 Conductors and cords .....	51
6.10 Identification and polarity .....	58
6.11 Electrical spacings .....	59
6.12 Electrical insulation .....	60
6.13 Accessibility of live parts .....	60
6.14 Grounding and bonding .....	62
6.15 Supply connections .....	67
6.16 Wiring compartment and junction box volume for branch circuit conductors .....	69
6.17 Separation of circuits .....	71
6.18 (MEX) Wire splices and connections .....	72
7 Incandescent luminaires – supplementary requirements .....	72

7.1	General	72
7.2	Temperature test-exempt luminaires	72
7.3	Tungsten-halogen luminaires	84
8	Fluorescent luminaires – supplementary requirements	89
8.1	General	89
8.2	Ballasts	89
8.3	Supply cords and conductors	89
8.4	Lampholders	90
8.5	Temperature-test-exempt luminaires	91
8.6	Marking	92
8.7	Emergency battery packs	93
8.8	Luminaires incorporating instant-start electronic ballasts and bi-pin lampholders	93
8.9	(CAN) Branch circuit disconnects	93
8.10	(CAN) Branch circuit disconnects — Conversion kits	94
9	HID luminaires – supplementary requirements	94
9.1	General	94
9.2	Lampholders	95
9.3	Lamp containment barriers for metal halide lamps	95
9.4	Ultra-violet (UV) attenuation barriers for metal halide lamps without integral UV blocking outer glass envelopes	96
9.5	Accessibility of double-ended lamp terminals	98
9.6	Marking	98
10	Surface-mounted luminaires – supplementary requirements	99
10.1	General	99
10.2	Mounting means	99
10.3	Poles	102
10.4	Open holes and openings	103
10.5	Accessibility of supply connections	108
10.6	Electrical construction	109
10.7	Tests	111
10.8	Markings	111
11	Recessed luminaires – supplementary requirements	111
11.1	General	111
11.2	Enclosures	112
11.3	Junction boxes	112
11.4	Recessed housing	114
11.5	Thermal protectors	115
11.6	Electrical construction	118
11.7	Tests	120
11.8	Markings	123
12	Miscellaneous luminaires – supplementary requirements	126
12.1	General	126
12.2	Air-handling luminaires	126
12.3	Luminaires for use above cooking equipment	130
12.4	Elevated ambient temperature luminaires	133
12.5	Luminaire fittings	133
12.6	(CAN) Exit signs	134
13	Environmental location luminaires – supplementary requirements	134
13.1	General	134
13.2	Damp and wet location luminaires	134
13.3	Damp location luminaires	134
13.4	Wet location luminaires	135
14	Normal temperature tests	141

14.1 General .....141

14.2 Surface ceiling luminaires .....143

14.3 Surface wall luminaires .....144

14.4 Under-cabinet luminaires .....145

14.5 Type Non-IC recessed luminaires (not intended for thermal insulation contact) ....145

14.6 Type Non-IC marked spacings luminaires (not intended for thermal insulation contact) .146

14.7 Type IC recessed luminaires (intended for thermal insulation contact) .....146

14.8 Type IC inherently protected recessed luminaires (intended for thermal insulation contact) .....147

14.9 Recessed luminaires for use in poured concrete .....147

14.10 Through-wiring junction box temperature .....147

14.11 Raceway temperature .....149

14.12 (MEX) Temperature rise .....149

15 Abnormal temperature tests .....150

15.1 General .....150

15.2 Type Non-IC recessed luminaires (not intended for thermal insulation contact) ....151

15.3 Type Non-IC marked spacings incandescent and HID recessed luminaires (not intended for thermal insulation contact) .....152

15.4 Type IC incandescent recessed luminaires (intended for thermal insulation contact) .154

15.5 Abnormal overlamping operation test for incandescent luminaires with polymeric housings or enclosures .....157

16 Mechanical tests .....157

16.1 Barrier strength .....157

16.2 Metal thickness equivalency .....158

16.3 Five-inch flame .....161

16.4 Mold stress relief .....162

16.5 Wet locations .....162

16.6 Hot-wire ignition (HWI) .....170

16.7 Glow-wire end product .....170

16.8 High-current arc ignition (HAI) .....172

16.9 End-product arc resistance .....172

16.10 Polymeric support .....173

16.11 Metallized polymeric parts coating adhesion .....173

16.12 Flaming oil .....173

16.13 Conduit knockout and twistout .....174

16.14 Self-threading screw torque .....174

16.15 Loading .....175

16.16 Snap-in or tab-mounted parts pull test without conduit opening .....175

16.17 Snap-in or tab-mounted parts pull test with conduit opening .....175

16.18 Suspended-ceiling luminaires – security of clips .....176

16.19 Movable joint rotation .....176

16.20 Movable joint torsion and pull .....176

16.21 Strain relief .....176

16.22 Tempered glass impact .....177

16.23 Glass support adhesive .....177

16.24 Glass supported by friction or adhesive .....178

16.25 Horizontal burning flame .....178

16.26 Vertical burning flame .....180

16.27 Needle flame .....182

16.28 Lamp containment barrier thermal shock .....183

16.29 Polymeric lamp containment barrier melt-through .....184

16.30 Polymeric connector loading .....184

16.31 Junction box rigidity .....184

16.32	Splice inspection	185
16.33	Lampholder mounting torque	185
16.34	Lampholder pull	186
16.35	Lampholder mounting bracket stop test	186
16.36	(MEX) Thermal shock	186
16.37	(MEX) Vibration	187
16.38	Lampholder lead pull	187
16.39	Ground-screw assembly strength	187
16.40	Cable pull test	188
16.41	Polymeric impact	189
17	Electrical tests	189
17.1	Dielectric voltage-withstand	189
17.2	Bonding circuit impedance	190
17.3	Interlock switch endurance	191
17.4	Articulate probe	191
17.5	(MEX) Insulation resistance	191
18	Factory production tests	191
18.1	Dielectric voltage-withstand	191
18.2	Grounding continuity	192
18.3	Glass support	193
18.4	Strain relief	193
18.5	Polarity	193
18.6	Ground screw torque	194
18.7	Test records	194
19	Test procedures and apparatus	194
19.1	Installation and support	194
19.2	Temperature test stabilization	194
19.3	Voltage	195
19.4	Frequency	196
19.5	Ambient temperature	196
19.6	Rise-of-resistance temperature method	198
19.6	(MEX) Temperature rise	198
19.7	Thermocouples	199
19.8	Test lamps	199
19.9	Branch circuit conductor temperature probe	204
19.10	Surface ceiling temperature test apparatus	206
19.11	Surface wall temperature test apparatus	208
19.12	Surface-mounted under-cabinet luminaire test alcove	210
19.13	Temperature test boxes for Type Non-IC recessed luminaries (not intended for thermal insulation contact)	212
19.14	Temperature test box for Type Non-IC, marked spacings, recessed ceiling-mounted luminaires (not intended for thermal insulation contact)	217
19.15	Temperature test box for Type IC recessed luminaries (intended for thermal insulation contact)	224
19.16	Thermal insulation used for recessed temperature tests	227
19.17	Rain test apparatus	227
19.18	Sprinkler test apparatus	230
19.19	Bond impedance and ground continuity test apparatus	232
19.20	Dielectric voltage-withstand test apparatus	232
19.21	Impact test apparatus	232
19.22	Articulate probe	234
19.23	Conduit knockout and twistout test apparatus	236
19.24	Five-inch flame test apparatus	238

19.25 UV exposure test apparatus ..... 240

19.26 Gasket compression test apparatus ..... 240

19.27 Lampholder mounting torque test apparatus ..... 240

19.28 Glow-wire test apparatus ..... 241

19.29 Horizontal burning flame test apparatus ..... 244

19.30 Vertical burning flame test apparatus ..... 244

19.31 Needle flame test apparatus ..... 246

19.32 Plywood test box material ..... 246

19.33 (MEX) Insulation resistance test apparatus ..... 247

19.34 (MEX) Vibration test apparatus ..... 247

20 Marking ..... 249

20.1 General ..... 249

20.2 Identification and ratings ..... 250

20.3 Durability of stamped ink marking test ..... 251

20.4 Luminaire mounting and orientation ..... 251

20.5 Wiring instructions ..... 251

20.6 (MEX) Marking requirements in Mexico ..... 251

**ANNEX A (normative) Standards for Components**

A.1 Component standards ..... 262

**Annex B (CAN) (normative) Markings – French Translations**

**Annex C (MEX) (normative) Markings – Spanish translations**

**Annex D (normative) Pictograms**

**Annex E (informative) Metric Conversion Information**

**Annex F (CAN) (normative) Printed Circuit Boards**

F.1 Special terminology ..... 296

F.2 General ..... 296

F.3 Printed circuit board coatings ..... 297

    F.3.1 Dielectric strength ..... 297

    F.3.2 Adhesion ..... 298

    F.3.3 Insulation resistance test voltage ..... 299

## Preface

This is the harmonized ANCE, CSA, and UL Standard for Luminaires. It is the first edition of NMX-J-307/1-ANCE, the third edition of CSA C22.2 No. 250.0, and the third edition of UL 1598. This edition of CSA C22.2 No. 250.0 supersedes the previous editions published in 2004 and 2000. This edition of UL 1598 supersedes the previous editions published in 2004 and 2000. The CSA Standard also replaces the Technical Information Letter TIL B-78, "Interim Certification Requirements for Ballast Disconnect Means in Fluorescent Luminaires Installed on Branch Circuits with Voltages Exceeding 150-Volts-to-Ground."

The Canadian Standards Association (CSA) and Underwriters Laboratories Inc. (UL) prepared the first edition of this common standard. The efforts and support of the Canadian Lamp and Fixture Manufacturers Association (CLFMA) and the American Lighting Association (ALA) are gratefully acknowledged. Later the same organizations with the added participation of the Association of Standardization and Certification (ANCE) and the National Electrical Manufacturers Association (NEMA) expanded the document to cover requirements for Canada, Mexico, and the United States.

This Standard is considered suitable for use for conformity assessment within the stated scope of the Standard.

This Standard was reviewed by the CSA Subcommittee on Lighting Products, under the jurisdiction of the CSA Technical Committee on Consumer and Commercial Products and the CSA Strategic Steering Committee on Requirements for Electrical Safety, and has been formally approved by the CSA Technical Committee.

This Standard has been approved by the American National Standards Institute (ANSI) as an American National Standard.

**NOTE** Although the intended primary application of this Standard is stated in its Scope, it is important to note that it remains the responsibility of the users of the Standard to judge its suitability for their particular purpose.

### Level of harmonization

This standard is published as an equivalent standard for ANCE, CSA, and UL. An equivalent standard is a standard that is substantially the same in technical content, except as follows. Technical national differences are allowed for codes and governmental regulations as well as those recognized as being in accordance with NAFTA Article 905, for example, because of fundamental climatic, geographical, technological, or infrastructural factors, scientific justification, or the level of protection that the country considers appropriate. Presentation is word for word except for editorial changes.

### Interpretations

The interpretation by the standards development organization of an identical or equivalent standard is based on the literal text to determine compliance with the standard in accordance with the procedural rules of the standards development organization. If more than one interpretation of the literal text has been identified, a revision is to be proposed as soon as possible to each of the standards development organizations to more accurately reflect the intent.

**ANCE effective date**

The effective date for ANCE will be announced through the *Diario Oficial de la Federation (Official Gazette)*.

**CSA effective date**

The effective date for CSA will be announced through *CSA Informs* or a CSA certification notice.

**UL effective date**

As of September 17, 2008, all products Listed or Recognized by UL must comply with the requirements in this standard except for clauses, figures, and tables in the following list, which are effective September 17, 2010.

Clauses 5.10.12, 6.13.2.5, 6.14.2.9, 8.8, 9.3.1, 9.4.1.1, 9.4.2.1, 12.2.4.6, 18.6, 16.38, and 16.39.

Between September 17, 2008 and September 17, 2010, new product submittals to UL may be evaluated under all requirements in this standard or, if requested in writing, evaluated under presently effective requirements only. The presently effective requirements are contained in the second edition of UL 1598.

A UL effective date is one established by Underwriters Laboratories Inc. and is not part of the ANSI approved standard.

## 1 Scope

1.1 This Standard applies to luminaires for use in non-hazardous locations and that are intended for installation on branch circuits of 600 V nominal or less between conductors in accordance with the *Canadian Electrical Code, Part I (CEC)*, CSA C22.1, with the U.S. *National Electrical Code (NEC)*, ANSI/NFPA 70, and with the Mexican National Electrical Code, NOM-001-SEDE.

1.2 This Standard does not apply to luminaires covered by other standards. The luminaires not covered by this Standard include

- Amateur Movie Lights;
- Aquarium Lights;
- Cabinet Lights;
- Decorative Lighting Strings;
- Combination Fan/IR Lamps Used for Heating;
- Electric Signs;
- Exit Signs in the United States;
- Junction Boxes for Swimming Pool Fixtures;
- Lamp Adapters;
- Low-Level Path Marking and Lighting Systems in the United States;
- Low-Voltage Landscape Lighting as follows:
  - For products intended for installation in Canada, landscape lighting systems that are 30 V nominal or less; and
  - For products intended for installation in Mexico, low-voltage landscape lighting devices that are 24 V nominal or less.
  - For products intended for installation in the United States, low-voltage landscape lighting devices that are of 15 V nominal or less;
- Low Voltage Lighting Fixtures for Use in Recreational Vehicles;
- Low Voltage Marine Lighting;
- Luminaires for Hazardous Locations;
- Luminaires for Recreational Vehicles;
- Marine Navigational Lights;
- Marine-Type Fixtures;
- Portable Electric Displays;
- Portable Hand Lamps;
- Portable Luminaires;
- Portable Sun/Heat Lamps;
- Self-Ballasted Lamps and Lamp Adapters;
- Stage and Studio Luminaires;
- Submersible Luminaires;
- Swimming Pools Luminaires;
- Temporary Lighting Strings;
- Therapeutic Lamps;
- Track Lighting Systems;
- Under-cabinet Lights in Canada and Cord-connected Under-cabinet Lights in the United States; and
- Unit Equipment for Emergency Lighting.

## 2 Reference publications

For undated references to standards, such reference shall be considered to refer to the latest edition and all revisions to that edition up to the time when this Standard was approved. For dated references to standards, such reference shall be considered to refer to the dated edition all revisions published to that edition up to the time the Standard was approved.

**ANCE (Mexican National Standards)**

NMX-J-198-ANCE-2005

*Electrical Products – Lighting – Ballast for fluorescent lights – Test methods*

NMX-J-230-ANCE-2001

*Ballast Lighting – Electromagnetics and electronics for mercury vapour lights of high pressure and metallic additives – Specifications and test methods*

NMX-J-547-ANCE-2005

*Lighting – Metal halide lamps – Specifications*

NMX-J-553-ANCE-2002

*Wires and cables – Weather resistance of insulation or jacket of electrical conductors – Test method*

NMX-J-565/2-11-ANCE-2005

*Fire hazard testing – Part 2-11: Glow/hot-wire-based test methods – Glow-wire flammability test*

NMX-J-565/3-ANCE-2006

*Safety requirements – Flammability of plastic materials for parts in devices and appliances – Test methods*

NMX-J-565/6-ANCE-2007

*Safety requirements – Hot wire resistance to ignition – Test method*

NMX-J-565/7-ANCE-2007

*Safety requirements – High-current arc resistance to ignition – Test method*

NOM-001-SEDE

*Mexican National Electrical Code*

NOM-064-SCFI-2000

*Electrical appliances – Lamps for indoor and outdoor use – Safety specifications and test methods***CSA (Canadian Standards Association)**

C22.1-06

*Canadian Electrical Code, Part I (CEC)*

C22.2 No. 0.15-01 (R2006)

*Adhesive Labels*

CAN/CSA-C22.2 No. 0.17-00 (R2004)

*Evaluation of Properties of Polymeric Materials*

C22.2 No. 62-93 (R2003)

*Surface Raceway Systems*

C22.2 No. 74-96 (R2005)

*Equipment for Use With Electric Discharge Lamps*

C22.2 No. 84-05

*Incandescent Lamps*

C22.2 No. 141-02  
*Unit Equipment for Emergency Lighting*

C22.2 No. 206-M1987 (R2004)  
*Lighting Poles*

**UL (Underwriters Laboratories Inc.)**

UL 5  
*Standard for Safety Surface Metal Raceways and Fittings*

UL 723  
*Standard for Test for Surface Burning Characteristics of Building Materials*

UL 746C  
*Standard for Polymeric Materials – Use in Electrical Equipment Evaluations*

UL 935  
*Standard for Safety Fluorescent-Lamp Ballasts*

UL 969  
*Standard for Marking and Labeling Systems*

**ANSI (American National Standards Institute)**

ANSI C78.380 (2005)  
*Electric Lamps — High Intensity Discharge Lamps, Method of Designation*

**ANSI/IESNA (Illuminating Engineering Society of North America)**

ANSI/IESNA RP-27 series of standards  
*Photobiological Safety for Lamps and Lamp Systems*

**ASME (American Society of Mechanical Engineers)**

ANSI/ASME B1.20.1-1983 (R2001)  
*Pipe Threads, General Purpose (Inch)*

**ASTM (American Society for Testing and Materials)**

ASTM D 635-03  
*Standard Test Method for Rate of Burning and/or Extent and Time of Burning of Plastics in a Horizontal Position*

ASTM D 1000-99  
*Standard Test Method for Pressure-Sensitive Adhesive-Coated Tapes Used for Electrical and Electronic Applications*

ASTM D 3801-00  
*Standard Test Method for Measuring the Comparative Burning Characteristics and Resistance of Solid Plastics in a Vertical Position*

ASTM D 5048-03

*Standard Test Method for Measuring the Comparative Burning Characteristics and Resistance to Burn Through of Solid Plastics Using 125 mm Flame*

ASTM G 151-00

*Standard Practice for Exposing Nonmetallic Materials in Accelerated Test Devices that Use Laboratory Light Sources*

ASTM G 153-00ae1

*Standard Practice for Operating Enclosed Carbon Arc Light-Apparatus for Exposure of Nonmetallic Materials*

ASTM G 155-00ae1

*Standard Practice for Operating Xenon Arc Light Apparatus for Exposure of Nonmetallic Materials*

ASTM MNL 12-1993

*Manual on the Use of Thermocouples in Temperature Measurements: Fourth Edition*

### **Government of Canada**

*National Building Code of Canada, 2005*

### **NFPA (National Fire Prevention Association)**

ANSI/NFPA 70-2005

*National Electrical Code (NEC)*

NFPA 90A-1993

*Standard for Installation of Air Conditioning and Ventilating Systems*

### **NIST (National Institute of Standards and Technology)**

NIST ITS-90

*Thermocouple Database*

### **IEC (International Electrotechnical Commission)**

IEC 60695-2-10:2000

*Fire hazard testing – Part 2-10: Glowing/hot-wire based test methods – Glow-wire apparatus and common test procedure*

### **ISA (The Instrumentation, Systems, and Automation Society)**

ISA MC 96.1-1982

*Temperature Measurement Thermocouples*

## **3 Definitions**

The following definitions apply in this Standard:

**Baffle** – a part of a luminaire that allows air passage but limits the emission of flame, arcs, or molten material from exiting the enclosure.

**Ballast** – in Canada and the United States, a device that by means of reactance or resistance, singly or in combination, limits the current of a lamp to the required value for proper operation and, where necessary, provides adequate starting voltage. In the case of rapid start circuits, it provides voltage for low-voltage lamp filament heating.

**Ballast (MEX)** – in Mexico an electromagnetic, electronic, or hybrid device that, through inductances, capacitances, resistances, and/or electronic elements (transistor, thyristors, etc.), alone or in combination, limit the lamp current, and, when necessary, the starting current and voltage. The electromagnetic and hybrid ballast has the same output frequency as the mains (60 Hz). Electronic ballasts are those that have at least one frequency converter.

**Ballast, fluorescent, thermally protected** – in Canada and the United States, a ballast that complies with the Class P requirement of UL 935 or the requirements for thermally protected ballasts in CSA C22.2 No. 74.

**Ballast, fluorescent, thermally protected (MEX)** – in Mexico, a ballast that contains a thermal protector or is inherently protected.

**Ballast, reactor (simple reactance)** – a reactance-type ballast in which the lamp ballasting impedance is provided by a single coil inductor, not a transformer or inductor with additional components.

**Ballast, remote** – a ballast that is not mounted on a luminaire, or one that is mounted on the luminaire 460 mm (18 in) or more from the luminaire housing, as measured from the nearest point on the ballast to the nearest point (other than an incidental projection) on the luminaire housing. The ballast may or may not be provided with the luminaire.

**Barrier** – a part of the luminaire intended to reduce the risk of shock or injury to persons.

**Bonding** – a low impedance path obtained by permanently joining all non-current-carrying metal parts to achieve electrical continuity and having the capacity to conduct any current likely to be imposed on it.

**Canopy** – a plate or similar fitting intended to provide a cover over an outlet box.

**Canopy, drop** – a canopy that can be lowered for access to the supply connections without lowering the luminaire. The canopy does not support the luminaire.

**CEC** – *Canadian Electrical Code, Part I.*

**Cellulosic** – a paper or wood type product that is treated or processed. Examples include insulation, paper, and fiber.

**Comply with** – a term to denote that the requirements specified for the construction or material have been fulfilled by

- (a) conducting a specified test;
- (b) confirming that a specified test has been conducted on the same or similar construction or material; or
- (c) determining by an engineering evaluation that equivalent, or greater, acceptable compliance has been demonstrated.

**Conductor, insulated** – a conductor encased within material recognized as electrical insulation.

**Conductor, neutral** – the identified grounded conductor, referred to as “the neutral”.

**Decorative part**– a part of the luminaire, outside the enclosure, that has no safety function.

**Diffuser** – a device to redirect or scatter the light from a source, primarily by the process of diffuse transmission.

**Electrical spacing** – the minimum distance, measured through the air or over an insulating surface, between an uninsulated live part and ground or between uninsulated live parts of opposite polarity.

**Electric-discharge lamp** – a lamp in which the light (or radiant energy near the visible spectrum) is produced by the passage of an electric current through a vapor or gas (e.g., a fluorescent or HID lamp, such as metal halide, sodium vapor, and mercury).

**Enclosure, electrical** – a part of the luminaire intended to reduce the risk of electric shock.

**Exit sign** – a luminaire used in buildings to identify the direct path of egress for emergency purposes. It contains a legend (EXIT and/or SORTIE) and optional directional indicator(s).

**Fixture** – referenced as a luminaire in this Standard.

**Flat glass** – a glass panel, usually formed from sheet stock, the overall shape of which is essentially flat. The panel can have a slight curvature or bend, and the surface may be smooth or textured.

**Gasket** – a resilient material used between two rigid surfaces.

**Ground screw assembly** – the combination of a machine or thread forming screw and a threaded hole in a metal part of the luminaire enclosure or mounting crossbar for the purpose of securing the branch circuit equipment-grounding conductor.

**Guard** – the part of a luminaire provided primarily for the purpose of reducing the risk of injury to persons by limiting user access to components that can have a high temperature or may be damaged by impact.

**Insulation, basic** – insulation applied to live parts to provide basic protection against electric shock.

**NOTE** In Mexico, basic insulation does not necessarily include insulation used exclusively for functional purposes.

**Insulation, supplementary** – independent insulation applied in addition to basic insulation.

**Knockout** – a partially cut-out opening that is closed until the precut material is removed.

**Lamp** – a device, intended to be inserted into a lampholder, that produces light (commonly called “light bulb”).

**Lamp compartment** – a construction for test-exempt luminaires that restricts the dissipation of heat.

**Lamp containment barrier** – any part of the luminaire that surrounds the lamp to contain hot particles of the lamp in the event it ruptures.

**Lampholder** – a wiring device intended for making connection to the electrical circuits of a lamp and, in some cases, providing support.

**Lamp-supported lampholder** – a lampholder supported by the lamp that, in turn, is supported by the luminaire.

**Live part** – a conductive part without basic insulation, where there is a risk of electric shock. The neutral conductor is considered to be a live part.

**Location, damp** – an exterior or interior location that is normally or periodically subject to condensation of moisture in, on, or adjacent to, electrical equipment, and includes partially protected locations.

**Location, dry** – a location not normally subject to dampness, but may include a location subject to temporary dampness, as in the case of a building under construction, provided ventilation is adequate to prevent an accumulation of moisture.

**Location, wet** – a location in which water or other liquid can drip, splash, or flow on or against electrical equipment.

**Luminaire** – a complete lighting unit consisting of a lamp or lamps, together with the parts designed to distribute the light, to position and protect the lamps and ballast (where applicable), and to connect the lamps to the power supply.

**Luminaire, canopy type** – a luminaire intended for installation through an opening in an outdoor canopy or marquee. It is not intended for indoor use or outdoor installations that can have thermal insulation installed.

**Luminaire, convertible** – a recessed luminaire that can be converted by the installer from a Type Non-IC to a Type IC or from a Type IC to Type Non-IC recessed luminaire.

**Luminaire, cord-connected** – a luminaire that is designed to be connected to the power source by means of a cord, with or without an attachment plug, and that is not normally moved from one place to another.

**Luminaire fitting** – a luminaire subassembly, such as a reflector, ballast assembly, enclosure end plate, mounting hanger assembly, adapter plate, pole, or other part, that is shipped separately and field-assembled to one or more other luminaire fittings or to an otherwise complete luminaire.

**Luminaire, ground-mounted recessed** – a luminaire in which the supply connection or electrical components are located below ground level.

**Luminaire, ground-mounted surface** – a luminaire mounted at ground level in which the supply connection or electrical components are located above ground level.

**Luminaire, pendant** – a luminaire that is designed to be suspended below the mounting surface.

**Luminaire, recessed** – a luminaire that is designed to be either wholly or partially recessed in a mounting surface.

**Luminaire, recessed finishing section** – the portion of the luminaire that consists of the recessed housing or the lampholder, or both, that is necessary to complete the luminaire.

**Luminaire, recessed rough-in section** – the portion of the luminaire that includes all electrical parts and wiring to which the branch circuit shall be connected but may not be provided with the recessed housing or the lampholder, or both.

**Luminaire, recessed, Type IC (intended for insulation contact)** – a recessed luminaire that is designed and identified for installation in a cavity filled with thermal insulation. The luminaire may be in direct contact with combustible materials and the insulation.

**Luminaire, recessed, Type IC, inherently protected (intended for insulation contact)** – a recessed luminaire that does not require a thermal protective device and that complies with the normal temperature limits of this Standard under all conceivable operating conditions.

**Luminaire, recessed, Type Non-IC (not intended for insulation contact)** – a recessed luminaire designed for installation in a cavity that has minimum dimensions and spacings to thermal insulation and combustible material in compliance with the installation code. It is not intended to be in contact or covered with thermal insulation.

**Luminaire, recessed, Type Non-IC, marked spacings (not intended for insulation contact)** – a recessed luminaire designed to be installed in a cavity where the clearance to combustible building members and thermal insulation are specified by the manufacturer.

**Luminaire, surface** – a luminaire that is designed to be mounted directly to a wall or ceiling surface.

**Manufacturer** – (for the purposes of this Standard) the company, agency, or individual submitting the product for evaluation; the term does not necessarily refer to the actual manufacturer of the product.

**NEC** – the *National Electrical Code* of the United States.

**Nominal system voltage** – the system-designated rms voltage.

**Open hole** – an aperture in a luminaire enclosure or a recessed housing that is not covered or filled by another part.

**Opening** – an aperture in an enclosure that is covered or filled by a plug or knockout and that has the potential of becoming an open hole.

**Ordinary tools** – tools that can normally be expected to be available to the user, such as screwdrivers, hammers, nut drivers, and pliers.

**Polymeric material** – a manufactured material comprised of a polymer or a combination of polymers, in combination with additives, such as colors, stabilizers, plasticizers, anti-oxidants, lubricants, anti-static agents, fillers, and reinforcing, that possess properties useful for fabrication of functional articles.

**Power limited circuit** — see *NEC*, Section 725 and *CEC*, Section 16.

**Recessed housing** – a part of a recessed luminaire that projects into the ceiling or wall cavity and serves to close off the opening from the room side, and does not necessarily enclose conductors or similar components.

**Risk of electric shock** – in Canada and the United States, a risk of electric shock exists between any two uninsulated conductive parts of a luminaire or between an uninsulated conductive luminaire part and earth ground if the continuous current flow through a 1500  $\Omega$  resistor in parallel with a 0.15 $\mu$ F capacitor connected between the two points exceeds 5 mA rms (7 mA peak) and if the open circuit voltage exceeds 30 V rms or 42.4 V peak for dry, damp, and wet locations.

**Risk of electric shock (MEX)** – in Mexico, a risk of electric shock exists between any two uninsulated conductive parts of a luminaire or between an uninsulated conductive luminaire part and earth ground if the continuous current flow through a 1500  $\Omega$  resistor in parallel with a 0.015 $\mu$ F capacitor connected between the two points exceeds 5 mA rms (7 mA peak) and if the open circuit voltage exceeds 30 V rms or 42.4 V peak for dry, damp, and wet locations.

**Risk of fire** – a risk of fire exists between two conductive parts if  $V_{max}$ ,  $I_{max}$ , or  $VA_{max}$  exceeds Class 2 circuit limitations as defined in Section 725 of *NEC*, Section 16 of *CEC*, and Section 725 of NOM-001-SEDE.

**Splice** – the joining of conductors:

- (a) by welding or soldering their ends together and applying an insulating outer covering that serves as basic insulation; or
- (b) using wire connectors, designed and certified for that purpose.

**Strain relief device** – a knot, bushing, clamp, or equivalent device designed to prevent strain from being transmitted through a conductor or cord to a termination point inside a luminaire.

**Tap conductor** – a conductor between the luminaire and the branch circuit.

**Tempered glass** – glass that is heated to near its softening point and then rapidly cooled under rigorous control to enhance its mechanical and thermal endurance by creating a compression stress on all surfaces and edges balanced by tension stress in the core.

**Thermal shock and impact-resistant tempered glass (MEX)** – in Mexico, glass that has undergone a heat treating process to give it certain hardness or elasticity characteristics.

**Through wire** – a current-carrying branch circuit conductor that does not supply the luminaire, but passes through the luminaire wiring compartment or integral junction box.

**User maintenance** – servicing operations, such as re-lamping and cleaning, expected to be carried out by untrained persons.

**Water shield** – a structural part of a wet location luminaire, relied upon to reduce or prevent the entrance of water into a luminaire or onto current-carrying parts.

**Wire binding screw** – a screw used to secure an electrical conductor.

**Wiring diagram** – a line drawing, graphic, and/or written instructions to identify conductors and make connections to the luminaire.

**Wiring terminal** – pressure or wire binding terminals used for making wiring connections.

## 4 General requirements

### 4.1 Components

4.1.1 Except as indicated in Clause 4.1.2, a component of a product covered by this Standard shall comply with the requirements for that component. See Annex A for a list of standards covering components generally used in the products covered by this Standard. A component shall comply with the ANCE, CSA, or UL Standards as appropriate for the country where the product is to be used.

4.1.2 A component is not required to comply with a specific requirement that:

- (a) involves a feature or characteristics not needed in the application of the component in the product covered by this Standard; or
- (b) is superseded by a requirement in this Standard.

4.1.3 A component shall be used in accordance with its rating established for the intended conditions of use.

4.1.4 Specific components are accepted as being incomplete in construction features or restricted in performance capabilities. Such components are intended for use only under limited conditions, such as temperatures not exceeding specified limits, and shall be used only under those specific conditions for which they have been investigated.

## **4.2 Application of requirements**

4.2.1 The requirements of the national installation codes and other practices of Canada, Mexico, and the United States have been addressed in the requirements of this Standard.

4.2.2 A product intended to be used in Canada, Mexico, and the United States shall comply with the requirements of this Standard for all countries.

4.2.3 A product to be used only in Canada, Mexico, or the United States shall comply with the common requirements of this Standard and the applicable country-specific requirements, where so noted and summarized in Table 4.2.1.

4.2.4 Products intended for use in Mexico shall comply with those requirements listed and summarized in Table 4.2.2 (MEX).

4.2.5 A country specific requirement clause has the same clause number as the requirement, but with the suffix (CAN), (MEX), or (USA). Table 4.2.1 provides a summary of the country-specific clauses, tables, and figures.

## **4.3 Units of measurement**

4.3.1 The values given in SI (metric) units shall be normative. Any other values shall be for information purposes only. See Annex E for metric conversion multipliers.

4.3.2 Temperatures are given in degrees Celsius only.

4.3.3 Unless indicated otherwise, all voltage and current values mentioned in this Standard are root-mean-square (rms).

**Table 4.2.1**  
**Summary of country-specific requirements**

(See Clauses 4.2.3 and 4.2.5)

**4 General requirements**

Table 4.2.2 (MEX) Requirements applicable to Mexico

**5 Mechanical construction**

5.7.1.1 (MEX) Polymeric materials, minimum thickness  
 Table 5.7.1 (MEX) Minimum thickness for polymeric materials  
 5.10.3 (MEX) Self-threading or sheet-metal screws  
 5.16.2.7 (MEX) Borosilicate and tempered glass

**6 Electrical construction**

6.4.1.4 (CAN) Caution marking not required  
 6.6.3 (USA) Fuseholder not required to disconnect all ungrounded conductors  
 6.7.1.3 (USA) Screwshell bonding to ground  
 Figure 6.7.1.1 (USA) Ballast and transformer connection diagrams for United States  
 6.7.1.4 (USA) Screwshell bonding to ground  
 6.9.2 (CAN) Conductors for use in Canada  
 Table 6.9.1 (CAN) CEC conductor temperature rating  
 6.9.2 (USA) Conductors for use in United States  
 Table 6.9.2 (USA) NEC conductor temperature and voltage ratings  
 Table 6.9.3 (USA) Appliance wiring temperature and voltage ratings  
 6.9.2 (MEX) Conductors  
 6.9.3 (MEX) Conductors  
 6.9.4 (MEX) Conductors smaller than 18 AWG  
 6.11.10 (CAN) Spacings for printed circuit boards  
 6.11.10 (USA) Spacings for printed circuit boards  
 6.13.2.5 (MEX) Lampholder lead pull test – not required  
 6.14.2.4 (CAN), 6.14.2.4 (MEX) Crossbar with grounding means not required  
 6.14.3.4 (USA) Bonding conductor for parts other than ballasts with integral enclosures  
 6.15.1.5 (CAN) Branch circuit conductor temperature 75 °C  
 6.18 (MEX) Wire splices and connections

**7 Incandescent luminaires – supplementary requirements**

7.1.2 (CAN) Marking – Caution marking not required  
 7.2.5.2 (CAN) Marking – Caution marking not required  
 7.2.6.1 (CAN) Marking – Caution marking not required  
 7.3.1.2 (CAN) Marking – Caution marking not required  
 7.3.1.4 (USA) Marking – Lamp barrier marking not required  
 7.3.2.1 (CAN) Marking – Caution marking not required  
 7.3.2.3 (CAN) Marking – Caution marking not required

**8 Fluorescent luminaires – supplementary requirements**

8.3.3 (CAN) Flexible supply cords for recessed luminaires  
 8.5.2 (USA) Luminaires that are test-exempt

**9 HID luminaires – supplementary requirements**

9.4.1.1 (MEX) Luminaires for use with metal halide lamps  
 9.5.1 (CAN) Marking – Caution marking not required  
 9.5.3 (CAN) Marking – Caution marking not required

Table 4.2.1 Continued on Next Page

**Table 4.2.1 Continued**

9.6.1 (MEX)	Marking – Lamp designation
9.6.6 (CAN)	Marking – Caution marking not required
<b>10 Surface-mounted luminaires – supplementary requirements</b>	
10.2.5 (USA)	Mounting means
10.2.14 (MEX)	Safety devices to support pendant luminaires greater than 6.8 kg
10.3.13 (CAN)	Additional requirements for lighting poles
10.6.7 (USA)	Installation instructions for power supply cords not mounted in place
10.6.9 (USA)	Branch circuit conductor temperature 60 °C
10.6.9 (CAN)	Branch circuit conductor temperature 75 °C
10.6.10 (CAN)	Branch circuit conductor temperature 75 °C
10.7.3 (CAN)	Under-cabinet luminaires
10.7.4 (MEX)	Pole or arm-mounted luminaires
10.8.1 (CAN)	Marking – Not required on carton
10.8.2 (USA)	Under-cabinet marking
<b>11 Recessed luminaires – supplementary requirements</b>	
11.1.1 (MEX)	Recessed luminaire supplementary requirements
11.6.2.1 (USA)	Tap conductors 24" long
Table 11.6.2.1 (USA)	Conductors in fittings
11.6.2.2 (USA)	Flexible conduit and fittings
11.7.1.8 (USA)	Finishing sections other than by luminaire manufacturer
11.8.1.12 (USA)	Marking – vapor barrier marking not required
11.8.2.1 (CAN)	Marking – Caution marking not required
11.8.2.5 (CAN)	Marking – Caution marking not required
<b>12 Miscellaneous luminaires – supplementary requirements</b>	
12.2.2.3 (USA)	Air-handling luminaires – Material in the air path
12.2.2.5 (CAN)	Air-handling luminaires – Plastic diffusers
12.2.2.5 (USA)	Air-handling luminaires – Plastic diffusers
12.2.4.3 (USA)	Marking – without listed diffuser
12.2.4.4 (USA)	Marking – Diffuser dependent on frame, shipped separately
12.2.4.6 (MEX)	Caution marking – not required
12.2.4.7 (CAN)	Marking – Luminaires in environmental air-handling spaces
12.6 (CAN)	Exit sign luminaires
<b>14 Normal temperature test</b>	
Table 14.1.2, Item 5 (CAN)	Outlet box supply conductors for dwelling – wall mount
Table 14.1.2, Item 5 (USA)	Outlet box supply conductors for dwelling – wall mount
14.12 (MEX)	Temperature rise
<b>16 Mechanical tests</b>	
16.5.2.7 (MEX)	Insulation resistance after the rain test
16.5.5.2 (MEX)	UV exposure conditioning
16.5.12.1 (MEX)	Paint adhesion
16.5.12.2 (MEX)	Paint adhesion
16.6.1 (MEX)	Hot-wire ignition
16.7.1 (MEX)	Glow-wire end-product
16.8.1 (MEX)	High-current arc ignition
16.14.1 (MEX)	Screw torque

Table 4.2.1 Continued on Next Page

**Table 4.2.1 Continued**

Table 16.14.1 (MEX)	Screw torque
16.36 (MEX)	Thermal shock
16.37 (MEX)	Vibration
<b>17 Electrical tests</b>	
17.5 (MEX)	Insulation resistance
<b>19 Test procedures and apparatus</b>	
19.3.3.1 (MEX)	Nominal voltage
19.3.4.1 (MEX)	Test voltage
19.6 (MEX)	Temperature rise
19.7.2 (MEX)	Thermocouple gauge size
19.24.1 (MEX)	Five-inch flame test apparatus
19.30.1 (MEX)	Vertical burning flame test apparatus
19.33 (MEX)	Insulation resistance test apparatus
19.34 (MEX)	Vibration test apparatus
Figure 19.34.1 (MEX)	Vibration table
<b>20 Marking</b>	
20.2.5 (CAN)	Bilingual marking
20.2.5 (MEX)	Markings in Spanish
20.6 (MEX)	Marking requirements in Mexico
20.6.1 (MEX)	General
20.6.2 (MEX)	Luminaires
20.6.3 (MEX)	Instruction sheets
20.6.4 (MEX)	Cartons
<b>Annexes</b>	
Annex B	(CAN) Table B.1 – Markings – French translations
Annex C	(MEX) Table C.1 – Markings – Spanish translations
Annex F	(CAN) Printed circuit boards

**Table 4.2.2 (MEX)**  
**Requirements applicable to Mexico**

(See Clause 4.2.4)

**1 Scope****2 Referenced publications****3 Definitions****4 General requirements**

4.1	Components
4.2.1	Application of national installation codes
Table 4.2.1	Summary of country specific requirements
Table 4.2.2 (MEX)	Requirements specific to Mexico

**5 Mechanical construction**

5.4	Barriers
-----	----------

Table 4.2.2 (MEX) Continued on Next Page

**Table 4.2.2 (MEX) Continued**

5.5	Metal thickness for enclosures
5.5.1	Metal thickness for enclosures
Table 5.5.1	Minimum thickness of uncoated sheet metal and extruded aluminum for enclosures
5.5.2	Metal thickness for receptacle mounting
5.6	Corrosion protection
5.6.1	Corrosion protection
5.6.2	Corrosion protection not required
5.6.3	Clause 5.6.1 does not apply to
5.6.4	Vitreous enamel protection
5.7	Polymeric materials minimum thickness
5.7.1.1 (MEX)	Polymeric materials thickness
Table 5.7.1 (MEX)	Minimum thickness for polymeric material
5.9	Conduit knockouts and twistouts
5.10	Mechanical joints and fastenings
5.10.1	Method of making joint
5.10.2	Self-threading screws
5.10.3 (MEX)	Self-threading screws
5.10.4	Conductor positioning
5.10.5	Self-threading screws extending into wiring compartment
5.11	Means of mounting
5.11.1	Means of mounting
5.12	Movable joints
5.12.1	Movable joints and conductors
5.12.2	Movable joint torsion and pull tests
5.13	Raceway tubing
5.13.1	Raceway tubing
5.14	Conductor protection
5.14.1	Conductor protection
5.16.2.7 (MEX)	Borosilicate and tempered glass
5.19	Continuous row mounting
5.19.1	Provision for coupling and marking
5.19.2	Adequate space for conductors
5.20	Raceways
5.20.1	Surface mounted or recessed luminaires
5.20.2	Raceway portion of luminaires
5.20.3	Temperature test requirement
<b>6 Electrical construction</b>	
6.2	Wiring devices
6.2.1	Supplementary requirements
6.2.2	Current carrying parts
6.2.3	Wiring devices rated AC
6.2.4	Wiring devices removable by a tool
6.2.5	Attachment plug ratings
6.3	Lampholders
6.3.1	Lampholder suitability
6.3.2	Lamp-supported lampholder
6.3.3	Husk or sleeve of lampholder
6.7	Ballasts and transformers
6.7.1	General

Table 4.2.2 (MEX) Continued on Next Page

**Table 4.2.2 (MEX) Continued**

6.7.1.1	Open circuit voltage
6.7.1.2	Provided with luminaire
6.7.1.3	Grounding
6.7.1.4	Accidental contact
6.7.1.5	Thermal testing of HID ballasts
6.7.2	Luminaires with remote ballasts or transformers
6.7.2.1	Without integral leads
6.7.2.2	Thermal protection
6.7.2.3	Marking
6.7.2.4	Marking
6.9	Conductors and cords
6.9.1	Current-carrying conductors
6.9.2 (MEX)	In Mexico conductors minimum of 16 AWG
6.9.3 (MEX)	In Mexico conductors smaller than 16 AWG
6.9.4 (MEX)	In Mexico conductors smaller than 18 AWG
6.9.5	Stranded conductor or cord
6.9.6	Conductors or cords pushed back
6.9.7	Temperature rating of conductor
6.9.8	Insulated wire connector voltage rating
6.10	Identification and polarity
6.10.1	Conductor terminal intended for connection with neutral conductor
6.10.2	Insulation of a conductor intended for connection with a neutral conductor
6.10.3	Identified terminal of a wiring device
6.10.4	Polarity marking for a cord-and-plug connected luminaire
6.11	Electrical spacings
6.11.1	Minimum spacings
6.11.2	Measurement of spacings
6.11.3	Spacings at fuses and fuseholders
6.11.4	Determination of spacings
6.11.5	Spacings between uninsulated live parts
6.11.6	Spacings between field wiring terminals
6.11.7	Spacings of a branch circuit conductor terminal
6.11.8	A film-coated conductor
6.11.9	A spade or ring terminal
6.13	Accessibility of live parts
6.13.1	General
6.13.2	Accessibility of uninsulated parts
6.13.3	Accessibility of insulated parts
6.13.4	Parts accessible only during user maintenance
6.14	Grounding and bonding
6.14.1	General
6.14.2.1	Provision for grounding
6.14.2.2	Grounding means location
6.14.2.3	Location of grounding terminal
6.14.2.4 (MEX)	Provision for mounting crossbar
6.14.2.5	Grounding conductor size
6.14.2.6	Grounding conductor termination hardware
6.14.2.7	Grounding conductors for pendant luminaires
6.14.2.8	Identification of insulated grounding conductor
6.14.2.9	A screw used for luminaire grounding

Table 4.2.2 (MEX) Continued on Next Page

**Table 4.2.2 (MEX) Continued**

Table 6.14.2.1	Ground screw size
Figure 6.14.2.1	Terminal-conductor relationship
6.14.2.10	Provision for luminaire grounding conductor
6.14.2.11	Terminal plate
6.14.2.12	Terminal block
6.14.2.13	Provision for post top type luminaires
6.15.2	Conduit connections
6.15.2.1	Closure plugs
6.15.2.2	Conduit openings
Table 6.15.2.1	Dimensions for conduit openings
6.15.2.3	Throat diameters
Table 6.15.2.2	Throat diameters for conduit openings
6.15.2.4	Configurations
6.15.2.5	Conduit bushings
6.16	Wiring compartment and junction box volume for branch circuits
6.16.1	Minimum volume
6.16.2	Calculations
6.16.3	Conductor volume
6.16.4	Wiring
6.16.5	Covers
6.18 (MEX)	Wire splices and connections
6.18.1 (MEX)	Protection of wire splices
6.18.2 (MEX)	Securing of wire splices

**7 Incandescent luminaires – supplementary requirements****8 Fluorescent luminaires – supplementary requirements****9 HID luminaires – supplementary requirements**

9.3	Lamp containment barriers for metal halide lamps
9.3.1	A luminaire employing a metal halide lamp
9.3.2	Lamp containment barrier security
9.3.3	Open holes in a lamp containment barrier
9.3.4	Lamp containment barrier construction
9.3.5	Minimum thickness
9.3.6	Compliance with the thermal shock test
9.3.7	Compliance with the melt-through test
9.4.1.1 (MEX)	Luminaires for use with metal halide lamps
9.6.1 (MEX)	Marking – Lamp designation

**10 Surface-mounted luminaires – supplementary requirements**

10.2	Mounting means
10.2.11	Luminaire supported by a chain or cable
10.2.12	Flexible cord as sole support
10.2.14 (MEX)	Pendant luminaire supported by ceiling grid
10.7	Tests
10.7.1	Normal temperature test
10.7.2	Ceiling or wall-mounted luminaire testing
10.7.3	Luminaire for under-cabinet mounting
10.7.4 (MEX)	Pole or arm-mounted luminaires

**Table 4.2.2 (MEX) Continued****12 Miscellaneous luminaries – supplementary requirements****13 Environmental location of luminaries – supplementary requirements**

13.1.2	Dry, damp, and wet location marking
13.4.2	Corrosion protection
13.4.2.1	Use of materials with Inherent resistance to atmospheric corrosion
13.4.2.2	Protection of exposed parts with surfaces of ferrous metal
13.4.2.3	Exceptions to protection
13.4.2.4	Exceptions to protection
13.4.2.5	Welds in ferrous metals
13.4.2.6	Vitreous enamel protections

**14 Normal temperature tests**

14.1	General
14.1.1	Test procedures
14.1.2	Summary of test procedures in Table 14.1.1
Table 14.1.1	Recessed luminaire temperature test
14.1.3	Rated wattage of lamp used
14.1.4	Temperature limits shall not exceed those in Table 14.1.2
Table 14.1.2	Maximum temperature limits
14.2	Surface ceiling luminaires
14.2.1	Luminaire appearance
14.2.2	Test apparatus
14.2.3	Pendant mounted luminaires
14.2.4	Pendant mounted or direct mounted luminaires
14.2.5	Luminaires for a noncombustible surface
14.2.6	Noncombustible marking
14.2.7	Supply conductor temperature
14.2.8	Test lamps
14.2.9	Temperatures limits shall not exceed those in Table 14.1.2
14.3	Surface wall luminaires
14.3.1	Test apparatus
14.3.2	Thermocouple location
14.3.3	Supply conductor temperatures
14.3.4	Test lamps
14.3.5	Temperature limits shall not exceed those in Table 14.1.2
14.12 (MEX)	Temperature rise
14.12.1 (MEX)	Temperature rise test
Table 14.12.1 (MEX)	Maximum temperature
Table 14.12.2 (MEX)	Insulation of wire splices
14.12.2 (MEX)	Temperature limits
14.12.3 (MEX)	Ambient temperature
14.12.4 (MEX)	Stable temperature

**15 Abnormal temperature tests****16 Mechanical tests**

16.5.2	Rain test
16.5.2.1	Conditions for rain test

**Table 4.2.2 (MEX) Continued**

16.5.2.2	Replicable parts to be removed
16.5.2.3	Rain test apparatus
16.5.2.4	Mounting instructions
16.5.2.5	Positioning of spray heads
16.5.2.6	Test sequence
Table 16.5.2.1	Rain test operating sequence
16.5.2.7	Rain test pass criteria
16.5.2.7 (MEX)	Insulation resistance test
16.5.5.2 (MEX)	UV exposure conditioning
16.5.12.1 (MEX)	Paint adhesion test
16.5.12.2 (MEX)	Paint test criteria
16.6.1 (MEX)	Hot-wire ignition
16.7.1 (MEX)	Glow-wire end product
16.8.1 (MEX)	High-current arc ignition
16.12	Flaming oil
16.14	Self-threading screw torques
16.14.1 (MEX)	Self-threading screw torque test
Table 16.14.1 (MEX)	Screw torque
16.15	Loading
16.15.1	Supporting device support
16.15.2	More than one support
16.15.3	Test results
16.22	Tempered glass impact
16.22.1	Breakage by impact
16.22.2	Test temperature
16.22.3	Specimen weight
16.22.4	Test safety
16.22.5	Test procedures
16.22.6	Particle weight
16.24	Glass support by friction or adhesive
16.24.1	Glass load test
16.24.2	Time of test
16.36 (MEX)	Thermal shock
16.36.1 (MEX)	Curved borosilicate glass
16.36.2 (MEX)	Tempered glass
16.37 (MEX)	Vibration
16.39	Ground screw assembly strength
16.40	Cable pull
16.40.8	Aging and dielectric test method – not applicable
16.41	Polymeric impact
<b>17 Electrical tests</b>	
17.5 (MEX)	Insulation resistance
<b>18 Factory production tests</b>	
<b>19 Test procedures and apparatus</b>	
19.1	Installation and support
19.1.1	Install luminaire to manufacturer's instructions
19.1.2	Adjust luminaire to produce maximum temperature

Table 4.2.2 (MEX) Continued on Next Page

**Table 4.2.2 (MEX) Continued**

19.1.3	Luminaire mounted to floor
19.1.4	Pole mounted luminaires
19.2	Temperature test stabilization
19.2.1	Temperature test normal and abnormal
19.2.2	Temperature measured by thermocouples
19.2.3	Ballast and transformer coils measured by thermocouple
19.2.4	Temperatures measured after stabilization
19.3.3.1 (MEX)	Nominal voltages for Mexico (incandescent)
19.3.4.1 (MEX)	Nominal voltages for Mexico (HID)
19.4	Frequency
19.4.1	Frequency sensitive equipment
19.5	Ambient temperature
19.5.1	Ambient temperature
19.5.2	Ambient temperature measured by thermocouple
19.5.3	Thermocouple immersed in mineral oil
19.5.4	Thermocouple container
19.5.5	Testing at elevated temperatures
19.6	Temperature rise
19.6.1 (MEX)	Method for temperature rise test
19.6.2 (MEX)	Measuring cold resistance
19.6.3 (MEX)	Connect load and energize
19.6.4 (MEX)	Measuring hot resistance
19.6.5 (MEX)	Time to measure hot resistance
19.6.6 (MEX)	Graph hot resistance values
19.6.7 (MEX)	Rise of resistance formula
19.7	Thermocouples
19.7.1	Temperatures to be measured by thermocouples
19.7.2	Thermocouple gauge size
19.7.2 (MEX)	Thermocouple gauge size
19.7.3	Referee temperature methods
19.7.4	Method of affixing thermocouple
19.7.5	Location of thermocouple for through wiring
19.33 (MEX)	Insulation resistance test apparatus
19.34 (MEX)	Vibration test apparatus
Figure 19.34.1 (MEX)	Vibration table

**20 Marking**

20.2.5 (MEX)	Markings in Spanish
20.6 (MEX)	Marking requirements for Mexico
20.6.1 (MEX)	General
20.6.2 (MEX)	Luminaires
20.6.3 (MEX)	Instruction sheets
20.6.4 (MEX)	Cartons

**Annexes**

Annex A	Standards for components
Annex C (MEX)	Markings – Spanish translations
Table C.1 (MEX)	Markings – Spanish translations

## 5 Mechanical construction

### 5.1 General

5.1.1 The requirements in Clause 5 shall be used in conjunction with the applicable supplementary requirements in this Standard.

5.1.2 A part removed during user maintenance shall be:

(a) designed to prevent replacement in a position that would affect the intended operation of the luminaire; or

(b) marked to indicate proper replacement, in accordance with Table 20.1.1, Item 1.33.

5.1.3 There shall be no sharp edges, burrs, or method of construction that can damage electrical insulation or reduce electrical spacings.

### 5.2 Assembly and packaging

5.2.1 All splices and electrical connections shall be completed at the factory, unless packaging requires partial disassembly. Only assembly and electrical connections that can be accomplished with ordinary tools or tools supplied with the luminaire shall be completed at the installation site.

5.2.2 A luminaire that requires partial assembly in the field shall be provided with assembly instructions as specified in Table 20.1.1, Item 1.33.

5.2.3 All the parts required to complete a luminaire shall be shipped together, or shipped separately and marked in accordance with Table 20.1.1, Item 1.8.

5.2.4 Parts such as decorative glassware may be shipped separately and do not require identification.

5.2.5 An unassembled luminaire with accessible non-current-carrying parts that can be energized after the luminaire is installed shall be provided with means for fastening and bonding those parts. The use of screws or snap-in or tab-mounted parts shall meet the intent of this requirement.

5.2.6 The number of conductors shall not exceed 5 when using a twist-on wire connector for field wire connection.

5.2.7 Conductors intended for field connection shall have matching identification by color, number, letter, or other acceptable means.

5.2.8 A field connection between conductors of adjoining sections shall be accessible for inspection without the disconnection of any portion of the wiring.

### 5.3 Enclosures

5.3.1 A luminaire enclosure shall perform the following functions:

- (a) reduce the risk of contact with live parts;
- (b) enclose electrical parts and components that can involve a risk of fire;
- (c) protect internal parts from mechanical damage; and
- (d) protect internal parts from the environment.

5.3.2 All splices, open coil devices, capacitors, leads or terminals for field connection of supply wires, and other arcing live parts shall be provided with an enclosure.

### 5.4 Barriers

5.4.1 A barrier shall be constructed of one of the following:

- (a) ferrous or nonferrous metal at least 0.41 mm (0.016 in) thick;
- (b) glass or ceramic at least 3 mm (0.118 in) thick;
- (c) impregnated glass fiber sleeving at least 0.25 mm (0.010 in) thick that is rated for the temperature involved;
- (d) vulcanized fiber at least 0.71 mm (0.028 in) thick; or
- (e) a polymeric material that complies with Clause 5.7.1.6.

5.4.2 A barrier, other than of polymeric material, may be of a thickness less than that specified in Clause 5.4.1 if it complies with the barrier strength test of Clause 16.1.

### 5.5 Metal thickness for enclosures

5.5.1 The thickness of an enclosure material constructed of:

- (a) sheet metal and extruded aluminum shall be in accordance with Table 5.5.1 or shall comply with the metal thickness equivalency test of Clause 16.2; and
- (b) cast metal shall be in accordance with Table 5.5.2 or shall comply with the metal thickness equivalency test of Clause 16.2.

**Table 5.5.1**  
**Minimum thickness of uncoated sheet metal and extruded aluminum for enclosures**

(See Clauses 5.5.1, 11.3.5, 11.3.7, 11.3.11, 12.3.2.2, and 16.2.5.1.1, and Table 5.5.2.)

Specific construction		Steel				Copper, brass, aluminum sheet, and extruded aluminum			
		Unreinforced		Reinforced		Unreinforced		Reinforced	
		mm	(in)	mm	(in)	mm	(in)	mm	(in)
At opening for conduit connection		0.66	(0.026)	0.66	(0.026)	0.81	(0.032)	0.81	(0.032)
Length more than 660 mm (26 in)	No electrical component support	0.51	(0.020)	0.41	(0.016)	0.56	(0.022)	0.43	(0.017)
	Electrical component support	0.66	(0.026)	0.51	(0.020)	0.71	(0.028)	0.56	(0.022)
Length not more than 660 mm (26 in)	No electrical component support	0.41	(0.016)	0.33	(0.013)	0.51	(0.020)	0.41	(0.016)
	Electrical component support	0.51	(0.020)	0.41	(0.016)	0.64	(0.025)	0.51	(0.020)
Length not more than 380 mm (15 in)	No electrical component support	0.41	(0.016)	0.33	(0.013)	0.51	(0.020)	0.41	(0.016)
	Electrical component support	0.41	(0.016)	0.41	(0.016)	0.51	(0.020)	0.51	(0.020)

**NOTES**

- (1) "Reinforced" refers to a form of construction that provides equivalent mechanical strength.
- (2) "No electrical component support" refers to the minimum thickness required for mounting of non-electrical parts.
- (3) Examples of acceptable methods of reinforcement are
  - (a) a single piece of sheet metal that is formed to result in a maximum internal angle of 120 degrees;
  - (b) 13 × 13 mm (0.5 × 0.5 in) 90 degrees formed from sheet steel, 0.81 mm (0.032 in) minimum thickness, used to divide a surface into small sections and, unless along the greater dimension, are additionally secured to the adjacent sides of the enclosure;
  - (c) flat steel bars, 9.5 mm (0.375 in) wide minimum, 3.2 mm (0.125 in) thick minimum, used and secured as in (b); and
  - (d) curved, ribbed, or flanged surfaces. A surface is considered to be flanged if the two opposite sides are bent 13 mm (0.5 in) or wider at right angles to the surface.
- (4) For coated or finished metals, the minimum thickness is considered to be obtained if the overall thickness exceeds that required in this table by at least 0.013 mm (0.0005 in) for each side coated or finished.
- (5) "Length" refers to the longest straight line that can be drawn on any unreinforced flat section.

**Table 5.5.2**  
**Minimum thickness of cast metal for enclosures**

(See Clauses 5.5.1, 11.3.7, and 11.3.11.)

Material	Unreinforced		Reinforced	
	mm	(in)	mm	(in)
Cast metal	3.2	(0.126)	2.4	(0.094)
Cast malleable iron	2.4	(0.094)	1.6	(0.063)
Permanent mold – cast aluminum	2.4	(0.094)	1.6	(0.063)
Die-cast metal	2.0	(0.079)	1.2	(0.047)

NOTE Reinforced dimensions are acceptable at the root of threads, for a surface that is curved or otherwise reinforced, and for a surface of such shape or size, or both, that the strength contemplated is provided. Areas for breakouts or similar reasons, may have thinner sections providing the strength of structure is not affected, but in no case be thinner than permitted for sheet metal. See Clause 5.5.1 and Table 5.5.1.

5.5.2 The thickness of a metal surface for mounting a convenience receptacle of the snap-in type shall comply with the receptacle manufacturer's metal thickness specification but shall not be less than 0.51 mm (0.020 in).

## 5.6 Corrosion protection

5.6.1 All ferrous metal parts, including hinges, bolts, and fasteners, exposed after assembly shall be protected against corrosion by painting, coating, or plating. Copper, aluminum, alloys of copper and aluminum, stainless steel, and similar materials having inherent resistance to atmospheric corrosion are not required to have additional corrosion protection.

5.6.2 Edges, punched holes, and spot welds in prefinished steel, enclosed steel pipe, and hanger locations for painting or plating in ferrous metals do not require any corrosion protection.

5.6.3 The requirements of Clause 5.6.1 shall not apply to the following:

- (a) bearings, sliding surfaces of a hinge or shaft, hinge pins, and similar parts located on the exterior of enclosures where such protection is not practicable; and
- (b) decorative parts.

5.6.4 Vitreous enamels may be used as a protective coating for ferrous sheet metal having a minimum thickness of 0.6 mm (0.025 in).

## 5.7 Polymeric materials

### 5.7.1 General

5.7.1.1 Polymeric materials shall comply with the applicable requirements of Clauses 5.7.1.2 to 5.7.1.7.

5.7.1.1 (MEX) In Mexico, polymeric materials shall have minimum thickness in accordance with Table 5.7.1 (MEX).

**Table 5.7.1 (MEX)**  
**Minimum thickness for polymeric materials**

(See Clause 5.7.1.1 (MEX).)

Specific construction		Polymeric sheet			
		Un-reinforced		Reinforced	
		mm	(in)	mm	(in)
At opening for conduit connection		1.016	(0.040)	1.016	(0.040)
Length more than 660 mm	No electrical component support	0.81	(0.032)	0.81	(0.032)
	Electrical component support	1.016	(0.040)	1.016	(0.040)
Length larger than 380 mm and up to 660 mm	No electrical component support	0.81	(0.032)	–	–
	Electrical component support	0.81	(0.032)	–	–
Length not more than 380 mm	No electrical component support	0.71	(0.028)	–	–
	Electrical component support	0.71	(0.028)	–	–

NOTES

(1) "Reinforced" refers to a form of construction that provides equivalent mechanical strength.

(2) "No electrical component support" refers to the minimum thickness required for mounting of non-electrical parts.

(3) Examples of acceptable methods of reinforcement are curved, ribbed, and flanged surfaces.

(4) "Length" refers to the longest straight line that can be drawn on any un-reinforced flat section.

5.7.1.2 An enclosure of polymeric material where all live parts are insulated or permanently spaced more than 0.8 mm (0.032 in) from the enclosure shall:

- (a) have a minimum 5VA flammability rating or comply with the five-inch flame test of Clause 16.3;
- (b) have a temperature rating equal to or greater than its maximum operating temperature in the luminaire;
- (c) comply with the polymeric impact test of Clause 16.41 for the parts that can be subject to impact after installation;
- (d) comply with the mold stress-relief test of Clause 16.4 for molded or formed thermoplastic material;
- (e) comply with the abnormal overlamping operation test in Clause 15.5; and

(f) be resistant to UV radiation where the material is exposed to the sun or to fluorescent or unjacketed metal halide light sources. The material shall be UV rated, tested in accordance with the UV exposure test of Clause 16.5.5, or comply with the exposure to UV light test of UL 746C.

5.7.1.3 An enclosure of polymeric material where any uninsulated live parts are located within 0.8 mm (0.032 in) of the enclosure shall comply with Clause 5.7.1.2 and shall:

(a) have a minimum hot-wire ignition rating (HWI) of 15 s or comply with the hot-wire ignition test of Clause 16.6 or the glow-wire end product test of Clause 16.7; and

(b) have a minimum high-current arc resistance to ignition rating (HAI) of 15 arcs or comply with the high-current arc ignition test of Clause 16.8 or the end-product arc resistance test of Clause 16.9.

5.7.1.4 An enclosure of polymeric material where arcing parts, such as unenclosed switch contacts, are located:

(a) more than 13 mm (0.5 in) from the enclosure shall comply with Clause 5.7.1.2;

(b) within 13 mm (0.5 in) of the enclosure shall comply with Clause 5.7.1.2 and the hot-wire ignition test of Clause 16.6 or the glow-wire end product test of Clause 16.7.

5.7.1.5 A polymeric part used to suspend another part shall:

(a) have a minimum HB flammability rating or comply with the horizontal burning flame test of Clause 16.25;

(b) have a temperature rating equal to or greater than the highest temperature measured on the part during the normal temperature test of Clause 14; and

(c) comply with the polymeric support test of Clause 16.10 when the suspended part weighs more than 0.9 kg (2 lb).

5.7.1.6 A polymeric material used as a barrier shall:

(a) have a minimum HB flammability rating or comply with the horizontal burning flame test of Clause 16.25;

(b) have a temperature rating equal to or greater than its maximum operating temperature in the luminaire;

(c) for molded or formed thermoplastic parts, comply with the mold stress-relief test of Clause 16.4; and

(d) comply with the barrier strength test of Clause 16.1.

5.7.1.7 A polymeric material that can affect the integrity of a grounding or bonding means shall:

- (a) have a minimum HB flammability rating or comply with the horizontal burning flame test of Clause 16.25;
- (b) have a temperature rating equal to or greater than its maximum operating temperature in the luminaire; and
- (c) in the case of thermoplastic parts, also comply with the mold stress-relief test of Clause 16.4 followed by the bonding circuit impedance test of Clause 17.2.

5.7.2 Metallized polymeric parts

5.7.2.1 Metallized polymeric parts coated with an electrically conductive material shall comply with the metallized polymeric parts coating adhesion test of Clause 16.11 if peeling of the conductive material from the polymeric parts can result in the risk of electric shock, fire, or operating temperature limits being exceeded.

5.7.2.2 The metallized parts that are accessible during user maintenance or component replacement without the use of tools and can involve the risk of shock shall be bonded to ground in accordance with Clause 6.14.3.

## 5.8 Baffles

5.8.1 A baffle shall:

- (a) be made of metal that complies with the appropriate requirements of Clause 5.5; or
- (b) be made of nonmetallic material that complies with the five-inch flame test of Clause 16.3 or has a minimum 5VA flammability rating; and
- (c) if made of perforated material, have one of the following constructions:
  - (1) a galvanized steel screen, or the equivalent, having a 14 x 14 mesh per square inch and wire with a minimum diameter of 0.46 mm (0.018 in);
  - (2) a perforated metal plate, having evenly distributed openings that are not more than 11 per cm<sup>2</sup> (71 per in<sup>2</sup>) and that have a maximum dimension of 1.6 mm (0.063 in); or
  - (3) a perforated panel that complies with the flaming oil test of Clause 16.12.

## 5.9 Conduit knockouts and twistouts

5.9.1 A conduit knockout or twistout shall be secured in place so it can be removed without distorting the enclosure but it remains in place during normal handling and shall comply with the conduit knockout and twistout test of Clause 16.13.

## 5.10 Mechanical joints and fastenings

5.10.1 The method of making a joint shall provide strength and rigidity and prevent turning that can result in movement of conductors or wiring devices after the assembly is completed.

5.10.2 Self-threading screws, including sheet-metal screws, used to secure electrical or enclosure component parts in place or together, shall comply with the self-threading screw torque test in Clause 16.14, when the screw threads into nonferrous metal or polymeric material.

5.10.3 A self-threading or sheet metal screw used for mounting or supporting a part that weighs more than 3.4 kg (7.5 lb) per screw shall comply with the self-threading screw torque test in Clause 16.14.

5.10.3 (MEX) In Mexico, a self-threading or sheet-metal screw used for mounting or supporting a part shall comply with the self-threading screw torque test of Clause 16.14.1 (MEX).

5.10.4 If threads of sheet-metal or self-tapping screws extend into a wiring compartment for a distance of more than 5 mm (0.2 in), the conductors shall be reliably positioned away from the projecting screws, or the conductors shall be sufficiently loose to prevent damage to the insulation.

5.10.5 Frictional contact between parts alone shall not be acceptable as means of preventing turning. Turning may be prevented by the use of a suitable lockwasher properly applied, a locknut seated against another nut, or an equivalent threaded assembly, or by some other equivalent method such as swaging or suitable adhesive. An additional means of holding is not required if the joint consists of a full tapered pipe thread.

5.10.6 A sheet metal nut for bolts larger than 6.4 mm (0.250 in) in diameter may be used to prevent turning or loosening if it is not depended upon for mechanical strength.

5.10.7 Sheet-metal nuts fabricated of heat-treated steel may be used:

- (a) for assembly;
- (b) to prevent turning of threaded tubing no larger than 1/4 IPS; or
- (c) on bolts or studs that are no larger than 6.4 mm (0.250 in) in diameter.

5.10.8 When used as a supporting device, unthreaded tubing joints shall comply with the loading test of Clause 16.15.

5.10.9 Enclosure parts shall be secured by positive mechanical means, such as screws, welding, or interference fit.

5.10.10 Enclosure parts may be secured by frictional contact alone under the following conditions:

- (a) the part does not have a knockout or conduit opening and complies with the snap-in or tab-mounted parts pull test without conduit opening of Clause 16.16; or
- (b) the part has a knockout or conduit opening and complies with the snap-in or tab-mounted parts pull tests with conduit opening of Clause 16.17.

5.10.11 Snap-in and tab-mounted parts that are secured together by interference fit alone and that have a knockout or conduit opening shall comply with the snap-in and tab-mounted parts test with conduit opening of Clause 16.17.

5.10.12 Decorative parts of a luminaire secured by friction alone or an adhesive alone shall comply with the loading test in Clause 16.15.

### **5.11 Means of mounting**

5.11.1 A luminaire shall have means for mounting, and if special hardware is required, the hardware shall be provided and shall comply with the loading test of Clause 16.15.

### **5.12 Movable joints**

5.12.1 A movable joint, such as a swivel joint or telescoping arm, containing conductors shall be constructed so that movement of the joint will not result in damage to the insulation of conductors. Rotation shall be limited to 370 degrees, or the movable joint shall comply with the movable joint endurance test of Clause 16.19.

5.12.2 A movable joint containing conductors shall comply with the movable joint torsion and pull tests of Clause 16.20 and shall remain intact and operable.

### **5.13 Raceway tubing**

5.13.1 Tubing shall be free from kinks or cracks, and if it is:

- (a) unthreaded metal tubing, it shall be at least 0.5 mm (0.020 in) thick;
- (b) threaded metal tubing, it shall be at least 1.0 mm (0.040 in) thick; or
- (c) metal tubing with rolled threads, it shall be at least 0.5 mm (0.020 in) thick.

## 5.14 Conductor protection

5.14.1 Conductors that pass over edges or through openings in metal shall be secured from contacting the edges or be protected from cutting and abrasion. For sheet metal less than 1.1 mm (0.042 in) thick, protection shall be provided by one of the following methods:

- (a) rolling the edge of the metal not less than 120 degrees;
- (b) a bushing or grommet of a material other than rubber at least 1.2 mm (0.047 in) thick; or
- (c) glass sleeving at least 0.25 mm (0.010 in) thick.

## 5.15 Strain relief

### 5.15.1 General

5.15.1.1 A strain-relief shall be provided for a flexible cord or conductor that can be subjected to pulling, pushing, flexing, or twisting after the luminaire has been installed.

5.15.1.2 A strain-relief device, including a bushing with an integral strain-relief means, shall be designed to limit the holding pressure without damaging the cord jacket or conductor insulation.

### 5.15.2 Flexible cord

5.15.2.1 A strain relief for a flexible cord shall comply with the 15.9 kg (35 lb) strain-relief test of Clause 16.21.1.

5.15.2.2 A strain relief shall be provided at both ends of a flexible cord when the cord supports a luminaire or luminaire part.

5.15.2.3 A strain relief shall be provided at only one end of a flexible cord under the following conditions:

- (a) the cord is attached directly to a wiring device, such as an attachment plug, by the wiring device manufacturer; or
- (b) comply with the strain-relief test of Clause 16.21.1.

5.15.2.4 A strain relief shall not be required at the canopy end of a cord-pendant luminaire if instructions, in accordance with Table 20.1.1, Item 1.33, are furnished with the luminaire to show the method of strain relief that shall be applied in the field, such as a knot in the cord.

5.15.2.5 A cord-equipped luminaire without an attachment plug shall be provided with one of the following:

- (a) a strain-relief device for use in a standard conduit opening; or
- (b) instructions to identify the strain relief to be used, in accordance with Table 20.1.1, Item 1.33.

5.15.3 Conductors

5.15.3.1 The strain relief for a conductor shall comply with the pull test of Clause 16.21.2.

**5.16 Glass**

5.16.1 General

5.16.1.1 Edges of glass accessible during normal use or maintenance shall be seamed, swiped, fire-polished, or similarly treated to eliminate sharpness.

5.16.2 Minimum thickness

5.16.2.1 The minimum thickness and exposed area of glass used as an enclosure shall be in accordance with Table 5.16.2.1.

**Table 5.16.2.1**  
**Thickness of glass panels**  
 (See Clauses 5.16.2.1 to 5.16.2.5.)

Exposed area of glass		Minimum thickness of glass			
		Flat glass		Curved glass	
cm <sup>2</sup>	(in <sup>2</sup> )	mm	(in)	mm	(in)
0 – 968	(0 – 150)	2.11	(0.083)	2.11	(0.083)
969 – 3226	(150 – 500)	2.54	(0.100)	2.11	(0.083)
3227 – 7097	(500 – 1100)	3.56	(0.140)	2.54	(0.100)
7098 – 9316	(1100 – 1444)	3.56	(0.140)	2.54	(0.100)

5.16.2.2 The minimum thickness and exposed area of flat glass panels, smooth or otherwise, shall be in accordance with Table 5.16.2.1.

5.16.2.3 The minimum thickness and exposed area of glass that is curved or bent, or of globes of any shape shall be in accordance with Table 5.16.2.1, unless the exposed area is less than 1774 cm<sup>2</sup> (275 in<sup>2</sup>).

5.16.2.4 Untempered glass that is not in accordance with the minimum thickness shown in Table 5.16.2.1 shall provide equivalent mechanical strength.

5.16.2.5 Tempered glass that is not in accordance with the minimum thickness and exposed area shown in Table 5.16.2.1 shall comply with the tempered glass impact test of Clause 16.22.

5.16.2.6 The minimum thickness of fluted, ribbed, or patterned glass shall be measured from a valley of one side to the other flat side, or between valleys on opposite sides.

5.16.2.7 (MEX) In Mexico, borosilicate and tempered glass shall comply with the thermal shock tests of Clause 16.36 (MEX).

## 5.17 Glass support

5.17.1 Glass shall be secured in place and shall not be subjected to undue strain that can result in breakage or release during normal use or maintenance.

5.17.2 Glass mounted in a frame that is required to be opened or removed for maintenance shall be secured to the frame.

5.17.3 Clips that are used to secure a glass panel to the frame shall overlap the glass at least 5 mm (0.20 in).

5.17.4 An adhesive material used as the sole support of glassware shall comply with the adhesive support test of Clause 16.23.

5.17.5 A channel or frame for holding glass diffusers shall be:

- (a) steel at least 0.4 mm (0.016 in) thick;
- (b) nonferrous metal at least 0.5 mm (0.020 in) thick; or
- (c) polymeric material at least 1.5 mm (0.059 in) thick.

5.17.6 Glass globes, glass panels, or decorative glass parts shall be secured by one or more of the following means:

- (a) a circular fitter with at least three supports;
- (b) a threaded stud and nut;
- (c) a threaded glass part and associated fitter;
- (d) a frictional contact assembly that complies with the glass support test of Clause 16.24;
- (e) an adhesive that complies with Clause 5.17.4;
- (f) its own weight in a frame or fitter that is not hinged; and
- (g) a straight rod with a stop or a hook through a hole in the glass.

## 5.18 Thermal insulation

5.18.1 Thermal insulation shall be fire-resistant material, such as glass fiber, inorganic material, or polymeric material.

5.18.2 A polymeric thermal insulation material shall:

- (a) have a temperature rating equal to or greater than the operating temperature in the luminaire; and
- (b) have a minimum HB flammability rating, or comply with the horizontal burning flame test of Clause 16.25.

5.18.3 Thermal insulation shall be reliably secured in place. It shall be attached to the luminaire in the correct position by at least one of the following means:

- (a) staples or bolts;
- (b) adhesive applied to at least one-third of the surface of the insulation;
- (c) parts of the luminaire that do not have to be removed for installation. A supply conductor projecting through the insulation is not acceptable for securing the insulation in place; and
- (d) other means if investigated and found to be mechanically equivalent.

5.18.4 Thermal insulation shall not be located within 6.4 mm (0.25 in) of any opening for the connection of conduit unless the insulation is attached to a cover or other part that will be removed when conduit is being attached to the luminaire.

5.18.5 Glass fiber thermal insulation provided as an integral part of the luminaire shall have a minimum density of 9.6 kg/m<sup>3</sup> (0.6 lb/ft<sup>3</sup>).

## 5.19 Continuous row mounting

5.19.1 A luminaire intended for continuous row mounting shall have provision for a coupling method and be marked in accordance with Table 20.1.1, Item 2.16.

5.19.2 A luminaire intended for continuous row mounting shall have adequate space for at least four 12 AWG branch circuit conductors.

## 5.20 Raceways

5.20.1 The requirements in Clause 5.20 shall apply to surface-mounted or recessed luminaires intended to serve as a raceway for conductors of a circuit other than the conductors of the branch-circuit supplying the luminaire.

5.20.2 The raceway portion of a luminaire shall comply with the applicable requirements of UL 5 or CSA C22.2 No. 62.

5.20.3 The luminaire shall comply with the temperature test of Clause 14.11 and be marked as suitable for use as a raceway, in accordance with Table 20.1.1, Item 1.7.

## 6 Electrical construction

### 6.1 General

6.1.1 The requirements in Clause 6 shall be used in conjunction with the applicable supplementary requirements in this Standard.

6.1.2 Current-carrying parts shall be copper, copper alloy, nickel alloy, or stainless steel, unless otherwise specified in this Standard.

### 6.2 Wiring devices

6.2.1 A wiring device shall be rated for the temperatures, locations, voltage, and current encountered during normal operation.

6.2.2 A luminaire incorporating a wiring device rated for ac use shall be marked with the frequency or for ac use only, in accordance with Table 20.1.1, Item 1.4 or 3.7.

6.2.3 A wiring device shall be prevented from any turning that can apply tension to conductor connections, result in damage to the conductor, or otherwise adversely affect the assembly. Friction alone between the mating parts of the assembly shall not be acceptable as a means to prevent turning.

6.2.4 Parts of wiring devices that are removable from outside the enclosure without the use of ordinary tools shall not result in access to live parts within the enclosure.

6.2.5 The rating of an attachment plug assembled to a flexible cord for connection to a branch circuit shall comply with Table 6.2.1.

**Table 6.2.1**  
**Attachment plug ratings for cord-connected luminaires**

(See Clause 6.2.5)

Maximum luminaire input rating in amperes	Minimum attachment plug rating in amperes
12	15
16	20
24	30
40	50

### 6.3 Lampholders

6.3.1 A lampholder of a luminaire shall be suitable for the application.

6.3.2 A lamp-supported lampholder shall be provided with stranded conductors.

6.3.3 A husk or sleeve made of treated cellulosic fiber, provided to electrically insulate the terminals and screwshell of a lampholder, shall be at least 0.8 mm (0.032 in) thick and shall be positively retained. If the wire terminals of the lampholder are accessible with the husk or sleeve removed, they shall be additionally enclosed in accordance with Clause 5.3.

6.3.4 The screwshell of a lampholder directly supplied by the branch circuit shall be connected to the neutral grounded conductor.

### 6.4 Switches

#### 6.4.1 General

6.4.1.1 A switch shall have a minimum ampere rating equal to the total load current it controls multiplied by the load factor shown in Table 6.4.1.1.

6.4.1.2 A switch shall disconnect all of the ungrounded conductors of a supply circuit simultaneously, except as specified in Clause 6.4.1.4.

6.4.1.3 A single-pole switch shall not be connected in the neutral grounded conductor.

6.4.1.4 When a single-pole photocontrol switch is used on a line-to-line supply, the luminaire shall be marked with a caution to disconnect the power before servicing, in accordance with Table 20.1.1, Items 3.18 and 3.6.

6.4.1.4 (CAN) In Canada, the caution marking of Table 20.1.1, Item 3.18, shall not be required.

6.4.1.5 A luminaire provided with a receptacle for a photocontrol shall be:

(a) shipped with the control or shorting plug; or

(b) marked to require the installation of the control or plug, in accordance with Table 20.1.1, Item 1.20.

**Table 6.4.1.1**  
**Switch rating load factor**

(See Clause 6.4.1.1.)

Type of load	Special use switches				General use switches
	L-rated (ac only)	T-rated (ac/dc)	Ampere rated (ac only)	Ampere rated (ac/dc)	Ampere rated (ac only)
Tungsten filament	1	1	3	3	1
Inductive	1	1	2	2	1
Receptacle	1	1	3	3	1

#### 6.4.2 Interlock switches

6.4.2.1 An interlock switch shall be rated for the load it controls or shall comply with Clauses 6.4.2.2 to 6.4.2.4.

6.4.2.2 A polymeric switch enclosure shall:

(a) have a minimum V-2 flammability rating, or shall comply with the vertical burning flame test of Clause 16.26 or the needle flame test of Clause 16.27; and

(b) have a temperature rating suitable for the temperature attained during the normal temperature test of Clause 14.

6.4.2.3 Current-carrying parts shall be copper, copper alloy, or stainless steel, except that stainless steel shall not be used for quick-connect terminals, solder terminals, and arcing parts.

6.4.2.4 An interlock switch shall comply with the interlock switch endurance test of Clause 17.3.

### 6.5 Receptacles

6.5.1 A convenience receptacle in a luminaire shall be a grounding type and marked for maximum load in accordance with Table 20.1.1, Item 3.3 or 3.4.

6.5.2 A convenience receptacle shall not be provided in a ground-mounted recessed or ceiling-mounted luminaire.

6.5.3 A luminaire may be provided with a maximum of one duplex or two single convenience receptacles.

## 6.6 Fuses and fuseholders

6.6.1 A replaceable fuse shall be of the type that requires mounting in a fuseholder.

6.6.2 The fuse identification and ampere rating shall be marked on or adjacent to the fuseholder as specified in Table 20.1.1, Item 3.5.

6.6.3 A fuseholder shall disconnect all ungrounded conductors of the supply circuit simultaneously during fuse replacement.

6.6.3 (USA) In the United States, the fuseholder is not required to disconnect all ungrounded conductors during fuse replacement.

6.6.4 A fuse shall not be connected in the neutral grounded conductor.

## 6.7 Ballasts and transformers

### 6.7.1 General

6.7.1.1 A luminaire incorporating a ballast or transformer having an open circuit voltage of more than 1000 V shall be marked not for use in dwellings, in accordance with Table 20.1.1, Item 2.5.

6.7.1.2 A ballast or transformer required to operate lamps of the type and wattage for which the luminaire was designed shall be provided with the luminaire and shall be wired in accordance with the diagram or instructions on or with the ballast. For luminaires designed for use with remote ballasts, see also Clause 6.7.2.

6.7.1.3 When a luminaire is intended to be connected to the line and neutral grounded conductors of a branch circuit, as shown in Figure 6.7.1.1, and is provided with:

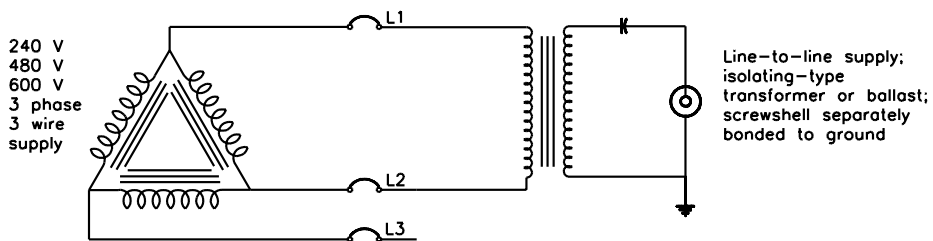
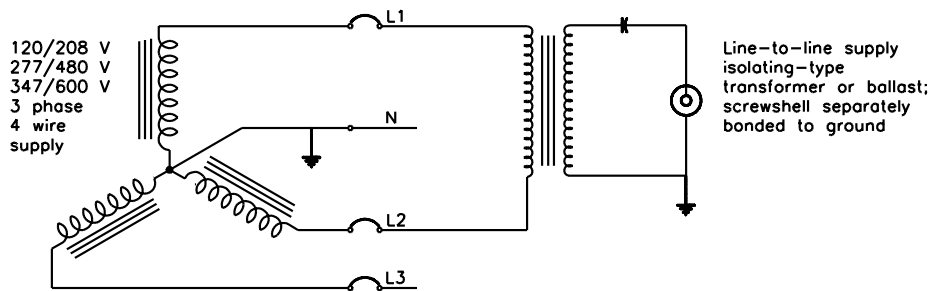
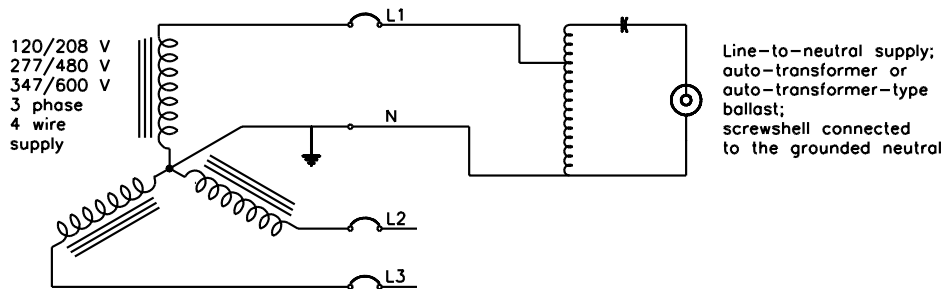
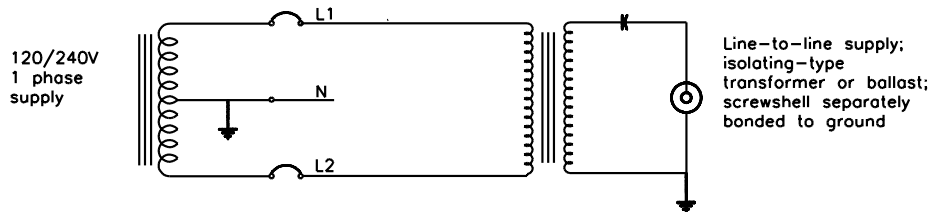
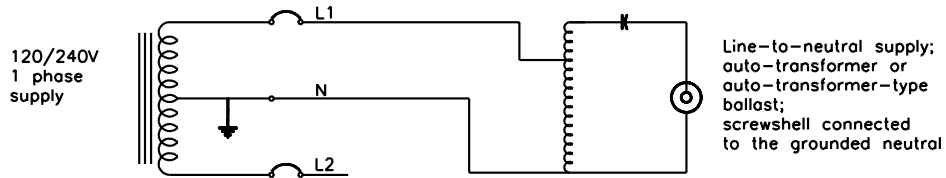
- (a) an auto-transformer or an auto-transformer-type ballast, the screwshell of the lampholder shall be connected to the neutral grounded conductor, unless provision is made to protect against accidental contact with the lamp screwbase during insertion or removal of the lamp; or
- (b) an isolating-type transformer or ballast, the screwshell of the lampholder shall be separately bonded to ground, unless provision is made to protect against accidental contact with the lamp screwbase during insertion or removal of the lamp.

6.7.1.3 (USA) In the United States, when a luminaire intended to be connected to the line and neutral grounded conductors of a branch circuit, as shown in Figure 6.7.1.1 (USA), and provided with:

- (a) an auto-transformer or an auto-transformer-type ballast, the screwshell of the lampholder shall be connected to the neutral grounded conductor, unless provision is made to protect against accidental contact with the lamp screwbase during insertion or removal of the lamp; or
- (b) an isolating-type transformer or ballast, the screwshell of the lampholder shall not be required to be separately bonded to ground.

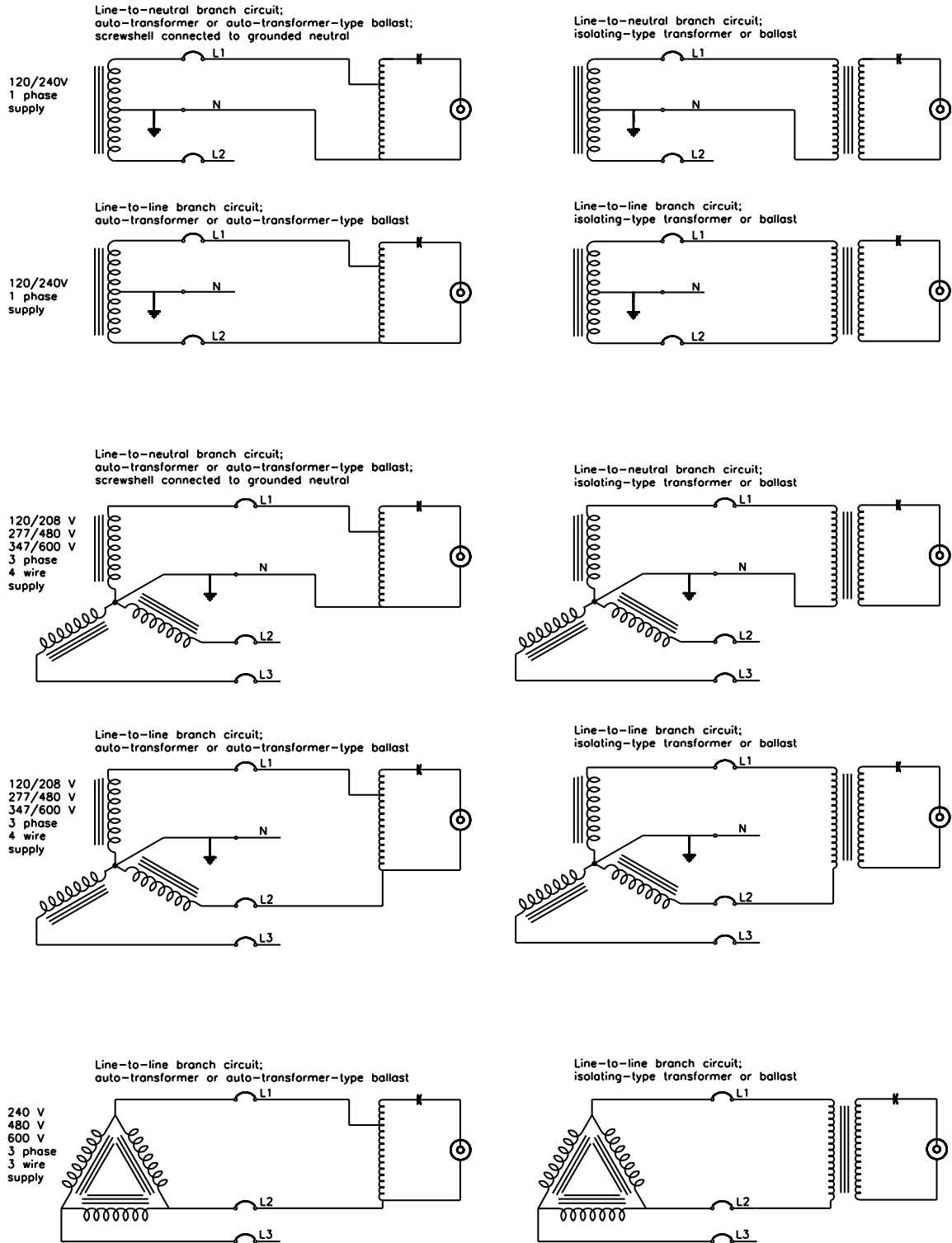
**Figure 6.7.1.1**  
**Ballast and transformer connection diagrams**

(See Clauses 6.7.1.3 and 6.7.1.4.)



**Figure 6.7.1.1 (USA)**  
**Ballast and transformer connection diagrams for United States**

(See Clauses 6.7.1.3 (USA) and 6.7.1.4 (USA).)



6.7.1.4 When a luminaire intended to be connected to the line-to-line conductors of a branch circuit, as shown in Figure 6.7.1.1, and is provided with:

- (a) an auto-transformer or auto-transformer-type ballast, provision shall be made to protect against accidental contact with the lamp screwbase during insertion or removal of the lamp; or
- (b) an isolating-type transformer or ballast, the screwshell of the lampholder shall be separately bonded to ground, unless provision is made to protect against accidental contact with the lamp screwbase during insertion or removal of the lamp.

6.7.1.4 (USA) In the United States, when a luminaire intended to be connected to the line-to-line conductors of a branch circuit, as shown in Figure 6.7.1.1 (USA), and provided with:

- (a) an auto-transformer or auto-transformer-type ballast, provision may be made to protect against accidental contact with the lamp screwbase during insertion or removal of the lamp; or
- (b) an isolating-type transformer or ballast, the screwshell of the lampholder shall not be required to be separately bonded to ground.

6.7.1.5 Allowing the thermal test results of one HID ballast to represent other HID ballasts shall be acceptable, with the following exceptions:

- (a) a metal halide or mercury vapor type shall not represent a high-pressure sodium type.
- (b) a high pressure sodium type shall not represent a metal halide or mercury vapor type.
- (c) a lower wattage shall not represent a higher wattage type.
- (d) a ballast with one class insulation system shall not represent a ballast with a different class insulation system.
- (e) for a ballast of other than the enclosed and potted type with a Class 105 insulation system, a ballast with a bench-test temperature shall not represent a ballast with a higher bench-test temperature.
- (f) a ballast that is not thermally protected shall not represent a ballast whose thermal protector:
  - (1) is buried within the ballast and has a temperature rating of less than the rating of the ballast system; or
  - (2) is located on the ballast core or under the wrap of an open coil and has a temperature rating of less than 90 °C for a Class 105 system, 110 °C for a Class 130 system, or 150 °C for a Class 180 system.

## 6.7.2 Luminaires with remote ballasts or transformers

6.7.2.1 A luminaire designed for use with a remote ballast or transformer and not provided with integral leads shall be provided with a means for terminating the ballast or transformer leads inside the luminaire.

6.7.2.2 A luminaire designed for use with a remotely mounted ballast or transformer shall be thermally protected if it is of incandescent or HID type and is intended for recessed mounting.

6.7.2.3 A luminaire designed for use with a remote ballast or transformer shall be marked with the watts and lamp type in accordance with Table 20.1.1, Item 1.41.

6.7.2.4 A luminaire designed for use with a remote ballast or transformer and required to be connected to secondary circuit conductors rated higher than 60 °C shall be marked to indicate the minimum acceptable temperature rating of the secondary conductors in accordance with Table 20.1.1, Item 1.1.

## 6.8 Capacitors

6.8.1 A capacitor, other than the type specified in Clause 6.8.2, shall be rated for the appropriate voltage and the maximum available fault current (AFC) to which it can be subjected, as follows:

- (a) a value of 10 000 A minimum when connected directly across the branch circuit;
- (b) a value of 200 A minimum when connected in series with a ballast coil; or
- (c) the maximum current available to the capacitor under capacitor short-circuit condition, as determined by investigation.

6.8.2 A dry metallized-film capacitor operating at a maximum of 330 V shall not be required to have a maximum available fault current rating.

6.8.3 A luminaire incorporating a capacitor as a component separate from the ballast shall:

- (a) have a maximum rating of 0.06 µF and a maximum operating potential of 500 V peak; or
- (b) provide means to discharge the capacitor within 1 min after removal of the capacitor voltage, in accordance with Clauses 6.8.4 to 6.8.6.

6.8.4 The means to discharge the capacitor may consist of a bleeder resistor or a closed loop of the circuit that is not opened by lamp removal or operation of a switch, fuse, or similar device.

6.8.5 The voltage across the capacitor terminals at the end of 1 minute shall be reduced to a value of 50 V or less, and the energy stored shall be less than 20 J, as determined by the equation:

$$J = 5 \times 10^{-7} CV^2$$

where:

J = the energy stored, J

C = the capacitor rating, µF

V = the capacitor peak voltage, V

6.8.6 The maximum value of a bleeder resistor shall be determined by the equation:

$$R = \frac{K}{C}$$

where:

R = the resistance value, MΩ

K = the resistor factor determined from Table 6.8.1

C = the capacitor rating, μF

**Table 6.8.1**  
**Bleeder resistor factor (K)**

(See Clause 6.8.6.)

Capacitor voltage		Factor (K)
RMS volts	Peak volts	
0 – 70	0 – 100	85
71 – 78	101 – 110	76
79 – 85	111 – 120	70
86 – 92	121 – 130	63
93 – 99	131 – 140	55
100 – 106	141 – 150	54
107 – 120	151 – 170	50
121 – 141	171 – 200	44
142 – 169	201 – 240	39
170 – 197	241 – 280	35
198 – 230	281 – 325	32
231 – 265	326 – 375	30
266 – 318	376 – 450	27
319 – 353	451 – 500	26
354 – 495	501 – 700	23
496 – 707	701 – 1000	19

NOTE For a transformer-type ballast, the voltage value to be applied according to this table is the rms voltage rating of the capacitor as specified on the ballast.

6.8.7 An oil-filled capacitor shall be provided with an expansion spacing between any luminaire part and the capacitor terminals in accordance with Clause 6.8.8, unless marked otherwise on the capacitor.

6.8.8 In addition to the electrical spacing required in Clause 6.11, the minimum expansion spacing perpendicular to the capacitor terminal shall be:

- (a) 11 mm (0.44 in) for a maximum of 300 V; or
- (b) 13 mm (0.50 in) for a voltage more than 300 V.

## 6.9 Conductors and cords

6.9.1 Current-carrying conductors shall be copper, copper alloy, or nickel alloy.

6.9.2 (CAN) In Canada, conductors shall be minimum 18 AWG, except as specified in Clause 6.9.3, and shall be rated for the voltage, current, temperature, and condition of service to which they will be subjected, in accordance with Table 6.9.1 (CAN).

**Table 6.9.1 (CAN)**  
**CEC conditions of use and conductor temperature ratings for flexible cords and equipment wires**

(See Clauses 6.9.2 (CAN), 6.13.3.2, and 6.13.3.3.)

Location	Usage	Description	Type	Rating, Volts	Temp.. °C	Notes
Dry	Not Hard Usage	Equipment Wire	GTF	600	125	1

Table 6.9.1 (CAN) Continued

Location	Usage	Description	Type	Rating, Volts	Temp., °C	Notes	
Dry or Damp	Not Hard Usage	Flexible Cord Equipment Wire	HPN	300	90	2	
			SPT-1	300	60		
			SPT-1	300	105		
			SPT-2	300	60		
			SPT-2	300	105		
			SV	300	60		
			SVO	300	60		
			SVT	300	60		
			SVT	300	105		
			CL751	300	75		1
			CL901	600	90		
			CL1051	300	105		
			CL1251	600	125		
			CL1251-R3	600	150		
			CL1502	600	150		
			REW (0.015)	300	105		
			REW (0.030)	600	105		
			SEW-1	300	200		
	SEWF-1	300	150				
	SEW-2	600	200				
	SEWF-2	600	150				
	TEW	600	105	1 & 2			
	TEWN	600	105	1 & 2			
	TR-32	600	105	1			
	TRB-32	600	105	1			
	TR-64	600	105	1			
	TRB-64	600	105	1			
	For Hard Usage	Flexible Cord	HSJO	300	90	2	
			SJ	300	60		
			SJO	300	60		
SJT			300	60			
SJT			300	105			
SPT-3			300	60			
For Extra Hard Usage	Flexible Cord	S	600	60	2		
		SO	600	60			
		ST	600	60			
		ST	600	105			
Dry or Damp or Wet	Not for Hard Usage	Flexible Cord	CXWT	300	60		
			CXWT	600	60		
			PXWT	300	60		
	For Hard Usage	Flexible Cord	SJOW	300	60		
			SJTW	300	60		
			SJTW	300	105		
	For Extra Hard Usage	Flexible Cord	SOW	600	60		
			STW	600	60		
			STW	600	105		
NOTES							
(1) A voltage of 1 000 V is permitted when the current is limited by a transformer, reactor, or resistor.							

Table 6.9.1 (CAN) Continued on Next Page

**Table 6.9.1 (CAN) Continued**

Location	Usage	Description	Type	Rating, Volts	Temp.. °C	Notes
(2) Temperature rating is limited to 60 °C when exposed to oil.						
(3) A temperature rating of 250 °C is permitted when the conductor is nickel or nickel-plated copper.						

6.9.2 (USA) In the United States, conductors shall be minimum 18 AWG, except as specified in Clause 6.9.3, and shall be rated for the voltage, current, temperature, and condition of service to which they will be subjected, in accordance with Tables 6.9.2 (USA) and 6.9.3 (USA).

**Table 6.9.2 (USA)**  
**NEC temperature and voltage ratings of flexible cords and equipment wire**

(See Clauses 6.9.2 (USA), 6.13.3.2, and 6.13.3.3.)

Location	Usage	Description	Type	Rating, V	Temp.. °C	Notes
Dry		Equipment wire				
			FEPW	600	75	
			PFAH	600	250	
			RH	600	75	
			RHH	600	90	
			T	600	60	
			TFE	600	250	
			THHN	600	90	
			THHW	600	90	
			Z	600	90	2
ZW	600	90	2			
Dry	Not hard usage	Flexible cord	C	300	60	
			PD	300	60	

Table 6.9.2 (USA) Continued

Location	Usage	Description	Type	Rating, V	Temp., °C	Notes			
Dry or damp		Equipment wire							
						FFH-1	300	75	
						FFH-2	600	75	
						KF-2	600	200	
						KFF-1	300	200	
						KFF-2	600	200	
						HF	600	150	
						HF-1	300	200	
						HFF	600	150	
						PAF	600	250	
						PAFF	600	150	
						PF	600	200	
						PFF	600	150	
						PGF	600	200	
						PGFF	600	150	
						PTF	600	250	
						PTFF	600	150	
						RFH-1	300	75	
						RFH-2	600	75	
						RFHH-2	600	90	2
						RHH	600	90	2
						RHH-3	600	90	2
						SF-1	300	200	
						SF-2	600	200	
						SFF-1	300	150	
						SFF-2	600	150	
						TF	600	60	
						TFF	600	60	
						THHN	600	90	2
						XHHW	600	90	2
						XF	300	150	
			XFF	300	150				
			Z	600	90	2			
			ZF	600	150				
			ZFF	600	150				
			ZHF	600	200				
			ZW	600	90	2			
Dry or damp	Not hard usage	Flexible cord	HPW	300	90	2			
	Extra-hard usage		S	600	60				
			S	600	75	1			
			SE	600	60				
			SE	600	75	1			

Table 6.9.2 (USA) Continued on Next Page

**Table 6.9.2 (USA) Continued**

Location	Usage	Description	Type	Rating, V	Temp., °C	Notes
	Hard usage		SJ	300	75	1
			SJE	300	75	1
			SJO	300	60	
			SJO	300	75	1
			SJOO	300	60	
			SJOO	300	75	1
			SJT	300	60	
			SJT	300	75	1
			SJT	300	90	1,2
			SJT	300	105	1,2
			SJTO	300	60	
			SJTOO	300	60	
	Not hard usage		SP-1	300	60	
			SP-2	300	60	
			SPE-1	300	60	
			SPE-1	300	75	1
			SPE-1	300	90	1,2
			SPE-1	300	105	1,2
			SPE-2	300	60	
			SPE-2	300	75	1
			SPE-2	300	90	1,2
			SPE-2	300	105	1,2
	Extra-hard usage		SO	600	60	
			SO	600	75	1
			SO	600	90	1,2
			SOO	600	60	
			SOO	600	75	1
			SOO	600	90	1,2
	Not hard usage		SPT-1	300	60	
			SPT-1	300	75	1
			SPT-1	300	90	1,2
			SPT-1	300	105	1,2
			SPT-2	300	60	
			SPT-2	300	90	1,2
			SPT-2	300	105	1,2
	Extra-hard usage		ST	600	60	
			ST	600	75	1
			ST	600	90	1,2
			ST	600	105	1,2
			STO	600	60	
			STOO	600	60	

Table 6.9.2 (USA) Continued

Location	Usage	Description	Type	Rating, V	Temp., °C	Notes
	Not hard usage		SV	300	60	
			SVE	300	60	
			SVO	300	60	
			SVO	300	90	1,2
			SVOO	300	60	
			SVOO	300	90	1,2
			SVT	300	60	
			SVT	300	75	1
			SVT	300	90	1,2
			SVT	300	105	1,2
			SVTO	300	60	
			SVTOO	300	60	
Dry, damp, or wet		Wire	RHW	600	75	
			RUW	600	60	
			THW	600	75	
			THWN	600	75	
			TW	600	60	
			XHHW	600	75	
			ZW	600	75	
Dry, damp, or wet	Same as specified for cord type under dry or damp	Flexible cord	Any if marked as specified in Note 3	As marked on cord	As marked on cord	2,3

NOTES:

(1) The insulation temperature rating is marked on the surface of the flexible cord.

(2) See Clause 6.9.7 for increasing the insulation temperature rating using sleeving.

(3) Flexible cord that is suitable for use in a wet location is surface marked with a "W" or "Water Resistant".

Table 6.9.3 (USA)

## Appliance wiring material insulation type, voltage, and temperature ratings for United States

(See Clauses 6.9.2 (USA) and 6.13.3.3.)

Types of insulation	Minimum thickness of insulation							
	300 volts			600 volts				
	Without braid		With added impregnated braid cover	Without braid		With added impregnated braid or nylon cover [min 0.1 mm (0.004 in)]		
mm	(in)	mm	(in)	mm	(in)	mm	(in)	
Thermoplastic	0.33	(0.013)	0.33	(0.013)	0.69	(0.027)	0.38	(0.015)
Thermoset	0.33	(0.013)	0.33	(0.013)	0.69	(0.027)	0.69	(0.027)
Rubber	0.69	(0.027)	0.33	(0.013)	1.02	(0.040)	0.69	(0.027)
Neoprene	0.69	(0.027)	0.33	(0.013)	1.07	(0.042)	0.69	(0.027)
Silicone rubber	–	–	0.33	(0.013)	–	–	0.69	(0.027)
Fluoro-plastic*	0.30	(0.012)	–	–	0.46	(0.018)	–	–

\*Polytetrafluoroethylene or fluorinated ethylene propylene.

NOTE The temperature marking of appliance-wiring material or miscellaneous wire consists of:

(1) colored threads;

(2) durable, continuous (unbroken), straight, longitudinal stripes printed in indelible ink on the surface of the insulation; or

(3) durable and legible indelible ink printing (or legible indent printing) of words, stating the temperature in degrees Celsius on (or in) the surface of the insulation.

Table 6.9.3 (USA) Continued on Next Page

**Table 6.9.3 (USA) Continued**

Types of insulation	Minimum thickness of insulation			
	300 volts		600 volts	
	Without braid	With added impregnated braid cover	Without braid	With added impregnated braid or nylon cover [min 0.1 mm (0.004 in)]
	mm (in)	mm (in)	mm (in)	mm (in)
The number and color of the threads or stripes are as follows: one green for 75 °C; one red for 90 °C; one yellow for 105 °C; one blue for 125 °C; one brown for 150 °C; one black for 200 °C; two black for 250 °C. If a stripe or thread is used to identify the temperature of an 80 °C thermoplastic-insulated wire (the identification is not required), the stripe or thread is green.				

6.9.2 (MEX) In Mexico, conductors shall be a minimum of 16 AWG (1.307 mm<sup>2</sup>) and shall be rated for the voltage, current, temperature, and conditions of service.

6.9.3 Conductors of a size smaller than 18 AWG may be used under the following conditions:

- (a) where they are completely enclosed;
- (b) where they are not subject to movement under normal use; and
- (c) in the secondary of a transformer, or in a circuit using solid-state devices.

6.9.3 (MEX) In Mexico, conductors of a size smaller than 16 AWG, but not smaller than 18 AWG, shall be permitted to be used where the current does not exceed 6 A.

6.9.4 Conductors of a size smaller than 24 AWG (0.21 mm<sup>2</sup>) may be used under the following conditions:

- (a) the conductors are in Class 2 power limited circuits only;
- (b) the current carrying capacity of the conductor is not exceeded and is sufficient to carry the continuous normal load current without any temperature related issues; and
- (c) the construction complies with Item (1) or (2), as follows:
  - (1) the conductors shall have an insulation rating not less than the voltage on the conductor and be stranded if accessible during use or maintenance, or inaccessible but subject to movement during maintenance, or
  - (2) the luminaire shall be provided with a barrier to prevent contact with wiring that is not connected to a Class 2 circuit. The width of an opening between a barrier and adjacent parts shall not exceed the diameter of the Class 2 circuit wire. This dimension shall be measured between the barrier and the enclosure walls, components, or the like that serve as part of the compartment for the Class 2 wiring.

6.9.4 (MEX) In Mexico, conductors of a size smaller than 18 AWG (0.82 mm<sup>2</sup>) but not smaller than 24 AWG (0.21mm<sup>2</sup>) may be used in the secondary of a transformer, ballast, or in a circuit using solid-state devices but they shall not be used in the power supply line.

6.9.5 A conductor or cord that can be flexed because of an adjustable, movable, or flexible part of a luminaire shall be of the stranded type and shall be secured so it will not be cut or abraded under conditions of intended use, including relamping, servicing, and inspection of supply connections.

6.9.6 In a luminaire construction that allows the conductor or cord to be pushed back into the luminaire, the temperature rating of the conductor or cord shall be suitable for the operating temperature of any component it can contact.

6.9.7 An insulated conductor, including each insulated conductor of a cord, that is rated for 90 °C, 105 °C, or 125 °C shall be considered as rated for 150 °C if each conductor is individually provided with supplemental insulation consisting of snugly fitting woven glass fiber sleeving having at least a 0.25 mm (0.010 in) wall thickness or at least two layers of glass fiber tape that provide a total thickness of at least 0.25 mm (0.010 in).

6.9.8 An insulated wire connector having a voltage rating less than that required for the application may be used if the splice, including the connector, is additionally covered with insulation rated for the voltage difference between the required voltage and the rated voltage of the connector.

## **6.10 Identification and polarity**

6.10.1 A conductor terminal intended for the connection of the neutral conductor of the branch circuit shall be substantially white in color or be marked neutral adjacent to the terminal in accordance with Table 20.1.1, Item 1.5.

6.10.2 The insulation on a conductor intended for connection to the neutral conductor of the branch circuit shall be identified by one of the following means:

- (a) be colored white or grey;
- (b) be of any color except green, with a continuous white tracer throughout its length;
- (c) be identified at the point where connected to the branch circuit by white paint, tape, ink, or permanent tag; or
- (d) be provided with one or more raised longitudinal ridges, if a parallel conductor flexible cord.

6.10.3 The identified terminal of a wiring device shall be connected to the neutral conductor of the branch circuit.

6.10.4 A cord-and-plug-connected luminaire equipped with a polarized two-pole, two-wire parallel blade attachment plug shall be marked for proper polarity in accordance with Table 20.1.1, Item 4.5.

## 6.11 Electrical spacings

6.11.1 The minimum spacings shall be not less than those shown in Table 6.11.1 between:

- (a) uninsulated live parts of different potential; and
- (b) uninsulated live parts and non-current-carrying metal parts.

**Table 6.11.1**  
**Minimum spacings – clearance through air and creepage distances for uninsulated live parts**

(See Clauses 6.11.1, 6.11.6, and 6.11.9.)

Voltage range, V rms	Voltage range, V peak	Minimum spacing clearance through air		Minimum spacing creepage distance	
		mm	(in)	mm	(in)
0 – 50	0 – 71	1.6	(0.063)	1.6	(0.063)
51 – 150	72 – 212	3.2	(0.125)	6.4	(0.250)
151 – 300	213 – 423	6.4	(0.250)	9.5	(0.375)
301 – 600	424 – 846	9.5	(0.375)	9.5	(0.375)
601 – 2000	847 – 2828	9.5	(0.375)	12.7	(0.500)

6.11.2 Spacings shall be measured with all fittings installed as intended, whether or not they are furnished with the luminaire. Parts that can be rotated after installation shall be moved to a position that minimizes the spacing being measured.

6.11.3 The spacings at fuses and fuseholders shall be measured with the fuses in place and with the fuses removed. The fuses shall be those with the maximum standard dimensions.

6.11.4 The spacing shall be determined using the voltage measured between the electrical parts, other than lamp igniters, operating under normal operation with the luminaire connected to a power supply of rated voltage and frequency.

6.11.5 The spacing between uninsulated live parts of different circuits involving different voltages shall be not less than that required for the circuit of the higher voltage.

6.11.6 The spacings between field wiring terminals of different potential and between the terminals and a grounded non-current-carrying part shall be not less than 3.2 mm (0.125 in) through air and 6.4 mm (0.250 in) over surface or as indicated in Table 6.11.1, whichever is greater.

6.11.7 The spacings of a branch circuit conductor terminal shall be measured with the conductor installed. The size of the conductor shall be suitable for the luminaire current rating but shall not be smaller than 14 AWG.

6.11.8 For the purposes of measuring spacings, a film-coated conductor shall be considered an uninsulated part.

6.11.9 A spade or ring terminal shall be prevented from turning by a reliable restraint such as a shoulder or boss, if by turning the spacing is reduced below the value shown in Table 6.11.1.

6.11.10 (CAN) In Canada, spacings for printed circuit boards shall comply with Annex F.

6.11.10 (USA) In the United States, spacings for printed circuit boards shall comply with applicable component and end product standards.

## 6.12 Electrical insulation

6.12.1 Electrical insulation, including that used in component wiring devices, shall be of material that is suitable for the particular application. The acceptability of insulating material shall include consideration of the following:

- (a) mechanical strength;
- (b) dielectric voltage-withstand;
- (c) insulation resistance;
- (d) heat-resistant and moisture-resistant properties;
- (e) degree of enclosure protection;
- (f) other factors, such as arcing and aging, that have a bearing on the risk of fire and electric shock under conditions of actual use; and
- (g) flammability rating (it shall be at least HB).

## 6.13 Accessibility of live parts

### 6.13.1 General

6.13.1.1 Accessibility of a live part shall be determined by the articulate probe test of Clause 17.4 during user maintenance and normal operation.

### 6.13.2 Accessibility of uninsulated parts

6.13.2.1 Uninsulated current-carrying parts specified in Clauses 6.13.2.2 to 6.13.2.4 may be accessible during user maintenance and normal operation. Contact with all other uninsulated current-carrying parts shall be prevented by an enclosure or barrier.

6.13.2.2 Electrical connections that are in the recess of a wiring device and that are covered with an electrical insulating material as shown in Table 14.1.2, Item 19, are considered to be inaccessible. The depth of the recess shall be at least 0.8 mm (0.032 in).

6.13.2.3 The live parts of a lampholder or starter holder that make the electrical connection to the lamp or starter may be accessible.

6.13.2.4 An uninsulated live part in the secondary circuit of an isolating transformer may be accessible if the maximum open circuit secondary voltage is 30 V rms or 42.4 V peak.

6.13.2.5 The lampholder leads of a wall mounted luminaire that are accessible from below or behind the lampholder with the luminaire fully assembled in accordance with the manufacturer's instructions shall comply with the lampholder lead pull test in Clause 16.38. Accessibility shall be determined by the articulated probe test of Clause 17.4.

6.13.2.5 (MEX) In Mexico, the lampholder lead pull test is not required.

### 6.13.3 Accessibility of insulated parts

6.13.3.1 Insulated current-carrying parts specified in Clauses 6.13.3.2 and 6.13.3.3 may be accessible during user maintenance and normal operation. Contact with all other insulated current-carrying parts shall be prevented by an enclosure or barrier.

6.13.3.2 The following conductors specified in Table 6.9.1 (CAN) or 6.9.2 (USA) shall be permitted to be used without additional mechanical protection:

- (a) flexible cord with insulation thickness equal to or greater than Type SPT-2;
- (b) flexible cord with insulation thickness equal to or greater than Type SPT-1, routed through the chain of a chain pendant luminaire; or
- (c) other conductors of minimum insulation thickness 0.80 mm (0.032 in), routed through the chain of a chain pendant luminaire.

6.13.3.3 Flexible cords, equipment wire, and 600 V rated appliance wiring material specified in Tables 6.9.1 (CAN), 6.9.2 (USA), and 6.9.3 (USA) may be accessible if:

- (a) visible for the entire accessible length;
- (b) routed, where practicable, to a structural part of the luminaire;
- (c) secured at least every 75 mm (3 in) if stranded wire or every 100 mm (4 in) if solid wire, where practicable, to a structural part of the luminaire, or threaded through chain links of the luminaire; and
- (d) in compliance with Item (1) or (2), as follows:

- (1) accessible for no more than 100 mm (4 in) and not containing any splices; or
- (2) enclosed in a minimum 0.25 mm (0.010 in) thick glass fiber or thermoplastic sleeving and factory-made splices using insulated crimp-type connectors are enclosed in a minimum 0.25 mm (0.010 in) thick glass fiber or thermoplastic sleeving.

#### 6.13.4 Parts accessible only during user maintenance

6.13.4.1 The following insulated current-carrying parts may be accessible to incidental contact only during user maintenance that requires an enclosure part to be removed or opened to accomplish the operation:

- (a) the terminals of electrical components, if insulated with material that is mechanically secured in place; and
- (b) any wiring or factory-made splices employing machine-applied twist-on wire connectors or other types of insulated wire connectors that are acceptable, if not disturbed during user maintenance.

### 6.14 Grounding and bonding

#### 6.14.1 General

6.14.1.1 Non-current-carrying metal parts and metallized polymeric parts that are accessible during user maintenance or component replacement without the use of tools and that can involve the risk of shock shall be bonded to ground and shall comply with the bond impedance test of Clause 17.2. A luminaire with non-current carrying parts bonded to ground shall have the resistance of the bonding circuit tested in accordance with Clause 17.2.1. If the resistance exceeds 0.10  $\Omega$ , the bonding circuit shall be tested as specified in Clause 17.2.3.

6.14.1.2 The following parts are not required to be bonded to ground:

- (a) the links of a metal chain used to support a pendant luminaire;
- (b) accessible non-current-carrying metal parts of luminaire components (for example, lampholders and switches) that are isolated from live parts; or
- (c) decorative parts, metal guards, and metal shades that do not enclose live parts.

6.14.1.3 An individual grounding conductor of a chain-and-canopy suspended luminaire shall be interwoven through the chain from the luminaire to the canopy. Installation instructions shall be provided in accordance with Table 20.1.1, Item 1.33.

## 6.14.2 Provision for grounding

6.14.2.1 A luminaire that requires grounding in accordance with Clause 6.14.1.1 shall be provided with a grounding means to provide connection to the branch circuit ground.

6.14.2.2 The grounding means shall be in the same location as the power supply connection means and shall be a pigtail lead grounding conductor, a pressure terminal connector, a wire binding screw, or the equivalent.

6.14.2.3 A grounding terminal shall not be located on a removable part, unless the removal of the part during user maintenance does not interrupt the bonding continuity.

6.14.2.4 A luminaire required to be grounded in accordance with Clause 6.14.1.1 and designed for mounting over an outlet box, but not incorporating a means to terminate the branch circuit grounding conductor, shall be provided with a mounting crossbar that has a grounding termination means.

6.14.2.4 (CAN) In Canada, a mounting crossbar shall not be required to have a grounding termination.

6.14.2.4 (MEX) In Mexico, a mounting crossbar shall not be required to have a grounding termination.

6.14.2.5 A grounding conductor shall not be smaller than the gauge of wire used for the luminaire supply conductors and in no case less than 18 AWG.

6.14.2.6 A grounding conductor shall not be terminated by hardware that is likely to be removed during replacement of any luminaire components.

6.14.2.7 The grounding conductor of a pendant luminaire may be terminated by hardware that is also used to secure a lampholder or lampholder bracket when that is the only available termination point.

6.14.2.8 An insulated grounding conductor shall be identified by one of the following:

- (a) green;
- (b) green with a yellow stripe; or
- (c) green with a yellow tracer.

6.14.2.9 A screw provided for luminaire grounding shall:

- (a) not be used for any other purpose;
- (b) be limited to conductors of size 10 AWG or smaller;
- (c) comply with Table 6.14.2.1;
- (d) have a cupped washer or similar provision, or the area around the screw shall be provided with two raised areas in accordance with Figure 6.14.2.1;
- (e) have a green-colored head, or the area directly adjacent to the screw shall be marked in accordance with Table 20.1.1, Item 4.4;
- (f) be a machine or thread-forming screw; and

(g) be capable of withstanding 1.6 N·m (14 lb-in) of tightening torque. Compliance is determined by the ground-screw assembly strength test in Clause 16.39.

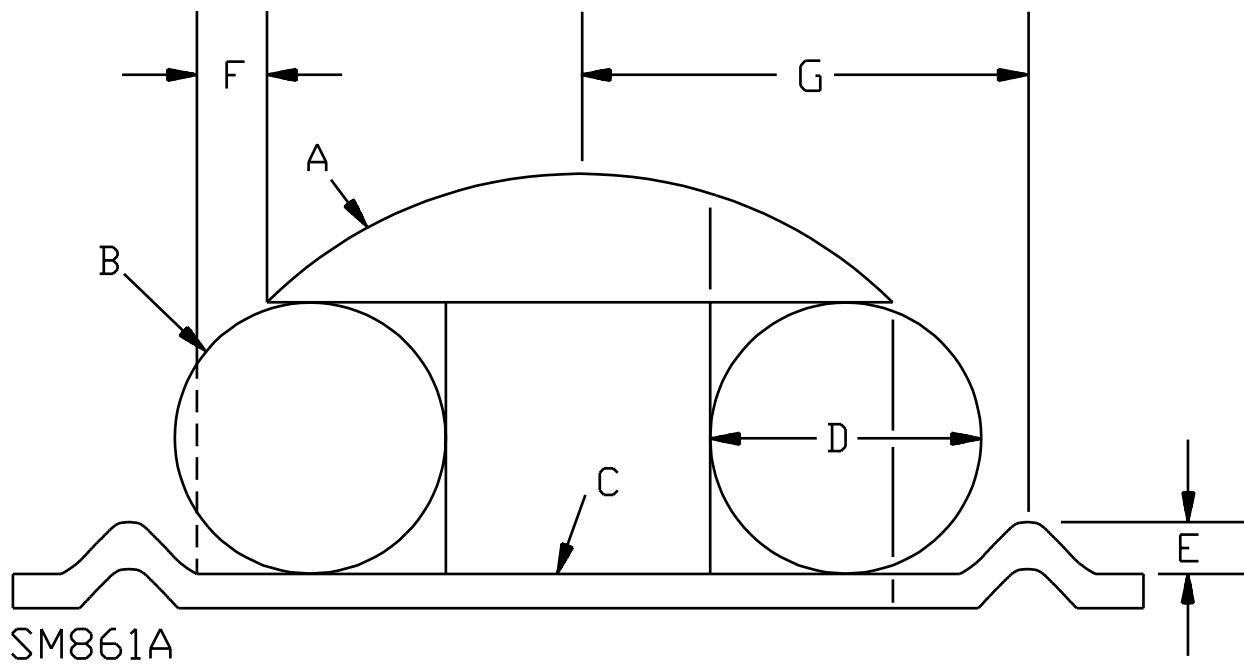
**Table 6.14.2.1**  
**Ground screw size**

(See Clause 6.14.2.9.)

Screw size		Wire size (AWG)
M3.5	(No. 6)	18 – 14
M4	(No. 8)	18 – 12
M5	(No. 10)	18 – 10

**Figure 6.14.2.1**  
**Terminal-conductor relationship**

(See Clause 6.14.2.9.)



Legend:

A – wire binding screw

B – conductor

C – terminal plate

D – maximum conductor diameter, but not less than 2 mm (0.08 in)

E – minimum height of raised areas = 1 mm (0.04 in)

F – the horizontal dimension from the edge of the screwhead to the inside edge of the raised area = 0 to 1/4 D

G – the horizontal dimension from the center of the raised area to the center of the screwhead = minimum 3.2 mm (0.125 in)

6.14.2.10 A luminaire grounding conductor may be secured to a snap-fit lampholder if the bonding between the lampholder and the luminaire complies with the bonding circuit impedance test of Clause 17.2.

6.14.2.11 A terminal plate intended for use with a wire binding screw shall be of metal and shall provide a minimum of two full threads engagement with the screw.

6.14.2.12 A pressure- or screw-type terminal block shall be suitable for the conductors involved, and grounding termination shall be marked with a grounding symbol or abbreviation in accordance with Table 20.1.1, Item 4.4.

6.14.2.13 A post top type luminaire that is intended to be conductively connected to a grounded pole or post and that does not comply with Clause 6.14.2.1 shall be provided with installation instructions in accordance with Table 20.1.1, Item 1.33.

### 6.14.3 Bonding

6.14.3.1 A bonding means shall consist of one of the following:

- (a) a pigtail lead bonding conductor of at least 18 AWG;
- (b) a terminal;
- (c) a welded, soldered, or brazed joint;
- (d) a screw, rivet, or welded stud;
- (e) a pressure terminal connector;
- (f) an assembly of bolt, nut, and lockwasher or starwasher, or other compressive fastener that complies with the bonding circuit impedance test of Clause 17.2; or
- (g) an equivalent conductive path that complies with the bonding circuit impedance test of Clause 17.2.

6.14.3.2 The bonding of a conductive part that is coated with vitreous enamel, paint, or similar coatings can require treatment of the part, such as masking, removal of the coating at points of connection, or the use of fastening means that penetrate the surface coating. If special treatment is required or if grounding continuity is not obvious, acceptability shall be determined by the bonding circuit impedance test of Clause 17.2.

6.14.3.3 The continuity of the grounding system shall not rely on the dimensional stability of thermoplastic material unless the material has a temperature rating equal to or greater than the maximum operating temperature of the material in the luminaire and complies with the mold stress-relief test of Clause 16.4, followed by the bonding circuit impedance test of Clause 17.2.

6.14.3.4 A luminaire part shall be provided with a 18 AWG or larger stranded bonding conductor if the part:

- (a) is required to be bonded to ground in accordance with Clause 6.14.1.1; and
- (b) is likely to be removed from the remainder of the luminaire during user maintenance and supports a live part.

6.14.3.4 (USA) In the United States, a luminaire part shall be provided with a 18 AWG or larger stranded bonding conductor if the part:

- (a) is required to be bonded to ground in accordance with Clause 6.14.1.1; and
- (b) is likely to be removed from the remainder of the luminaire during user maintenance and supports a live part, other than a ballast with an integral enclosure.

6.14.3.5 A bonding conductor shall be secured by one of the following methods:

- (a) a machine screw and nut;
- (b) a screw that threads into metal, with at least two full threads engaging;
- (c) rivets; or
- (d) equivalent means as determined by investigation.

6.14.3.6 The bonding conductor shall not be smaller than the gauge of wire used for the luminaire supply conductors and in no case less than 18 AWG.

6.14.3.7 A chain shall not be considered an effective bonding means.

## **6.15 Supply connections**

### **6.15.1 Power supply connections**

6.15.1.1 A luminaire shall be provided with a means of connection to a single branch circuit and shall have one or more of the following:

- (a) conductors, when mounted on or over an outlet box;
- (b) provision for connection of conduit as specified in Clause 6.15.2;
- (c) a length of a flexible cord;
- (d) tap conductors as specified in Clause 11.6.2;
- (e) a pressure or screw terminal block;
- (f) provision for a proprietary wiring system, and be marked in accordance with Table 20.1.1, Item 1.12, or installation instructions in accordance with Table 20.1.1, Item 1.33; or
- (g) provision for connection of cable.

6.15.1.2 The supply connection and grounding connection shall be accessible for inspection after installation as specified in Clause 10.5 or 11.6.1, as applicable.

6.15.1.3 A luminaire shipped with an unconnected cord shall be provided with a strain-relief device and a wiring diagram with assembly instructions in accordance with Table 20.1.1, Item 1.33.

6.15.1.4 A luminaire marked for branch circuit conductors rated more than 90 °C shall be marked not for use in dwellings, in accordance with Table 20.1.1, Item 2.5.

6.15.1.5 A luminaire that requires branch circuit conductors rated higher than 60 °C, as determined during the normal temperature tests in Clause 14, or that complies with the temperature-test-exempt requirements of Clause 7.2 shall be marked with the minimum temperature rating of the branch circuit conductors in accordance with Table 20.1.1, Item 1.1.

6.15.1.5 (CAN) In Canada, a luminaire that requires branch circuit conductors rated higher than 75 °C, as determined during the normal temperature tests in Clause 14, or that complies with the temperature-test-exempt requirements of Clause 7.2 shall be marked for the temperature rating of the branch circuit conductors in accordance with Table 20.1.1, Item 1.1.

6.15.1.6 A luminaire intended to be mounted on or over an outlet box shall be provided with supply conductors long enough to extend 150 mm (6 in) into the outlet box.

6.15.1.7 A post or pole mounted luminaire shall be provided with supply conductors extending 150 mm (6 in) beyond the field wiring compartment.

## 6.15.2 Conduit connections

6.15.2.1 A luminaire provided with a means of conduit connection shall be shipped with provision to close all but one of the conduit openings. Closure plugs may be packaged separately with the luminaire.

6.15.2.2 The dimensions for the unthreaded opening and the minimum unobstructed diameter of the flat surface surrounding the back of an opening for conduit shall comply with the values shown in Table 6.15.2.1.

**Table 6.15.2.1**  
**Dimensions for conduit openings**

(See Clauses 6.15.2.2 and 6.15.2.5.)

Nominal trade size of conduit	Unthreaded opening diameter		Minimum diameter of flat surface	
	mm	(in)	mm	(in)
1/2	22.2	(0.875)	28.09	(1.11)
3/4	28.2	(1.109)	34.04	(1.34)
1	34.9	(1.375)	42.85	(1.69)
1-1/4	44.0	(1.734)	55.07	(2.17)
	Tolerance			
	+0.81	+(0.032)		
	-0.38	-(0.015)		

6.15.2.3 The unthreaded part of a hole and the back edge of an opening not threaded all the way through shall be smooth and well rounded for protection of the conductors. The unthreaded throat diameter shall have a minimum internal diameter as shown in Table 6.15.2.2.

**Table 6.15.2.2**  
**Throat diameters for conduit openings**

(See Clause 6.15.2.3.)

Nominal trade size of conduit	Minimum throat diameter		Maximum throat diameter	
	mm	(in)	mm	(in)
1/2	13.4	(0.528)	15.8	(0.622)
3/4	17.7	(0.697)	20.8	(0.819)
1	22.4	(0.882)	26.7	(1.051)
1-1/4	29.7	(1.169)	35.1	(1.382)

6.15.2.4 A threaded opening shall have one of the following configurations:

- (a) when tapped all the way through, the opening shall have at least 3.5 threads but no more than 5 threads; or
- (b) when not tapped all the way through, the opening shall have at least 5 threads.

6.15.2.5 The minimum unobstructed diameter surrounding the back of an opening threaded all the way through shall comply with the minimum diameter of flat surfaces as shown in Table 6.15.2.1, to accommodate the conduit bushing.

## 6.16 Wiring compartment and junction box volume for branch circuit conductors

6.16.1 The minimum volume of a field wiring compartment or junction box for branch circuit connections shall be determined as follows:

- (a) by calculating the required minimum volume in accordance with Clauses 6.16.2 and 6.16.3; or
- (b) by providing a representative sample for engineering evaluation in accordance with Clauses 6.16.4 and 6.16.5.

6.16.2 The calculation shall include the following:

- (a) branch circuit conductors entering the luminaire;
- (b) branch circuit conductors leaving the luminaire;
- (c) insulated grounding conductors;
- (d) insulated bonding conductors;
- (e) ballast conductors;
- (f) lampholder conductors;
- (g) through wire conductors;
- (h) control device conductors; and

- (i) other accessory conductors.

6.16.3 Table 6.16.1 shall be used to determine the conductor volume for the calculation, and the following conditions shall apply:

- (a) the volume of a wiring compartment or junction box with only one conduit or cable entry shall be calculated using two 12 AWG branch circuit conductors and one 12 AWG insulated grounding conductor;
- (b) the volume of a wiring compartment or junction box with more than one conduit or cable entry shall be calculated using two 12 AWG branch circuit conductors entering, two 12 AWG branch circuit conductors leaving, and two 12 AWG insulated grounding conductors;
- (c) where the luminaire requires branch circuit conductors larger than 12 AWG, the input ampere rating shall determine the conductor size; and
- (d) uninsulated grounding or bonding conductors integral to the luminaire shall not be counted.

**Table 6.16.1**  
**Conductor volume for determination of the minimum wiring compartment or junction box volume**

(See Clause 6.16.3.)

Wire size, AWG	Conductor volume	
	cm <sup>3</sup>	(in <sup>3</sup> )
18	8.2	(0.5)
16	9.8	(0.6)
14	12.3	(0.75)
12	16.4	(1.0)
10	27.9	(1.7)

6.16.4 A sample of the wiring compartment or junction box provided for engineering evaluation shall be wired as intended, and the following shall apply:

- (a) conductors entering, leaving, or residing in the wiring compartment or junction box shall extend at least 150 mm (6 in) inside;
- (b) wire connectors of the appropriate type and size shall be used;
- (c) a wiring compartment or junction box with only one conduit or cable entry shall be wired with at least two 12 AWG branch circuit conductors and one 12 AWG insulated grounding conductor;
- (d) a wiring compartment or junction box with more than one conduit or cable entry shall be wired with at least two 12 AWG branch circuit conductors entering, two 12 AWG branch circuit conductors leaving, and two 12 AWG insulated grounding conductors;
- (e) the required number of insulated or uninsulated bonding conductors shall be installed;
- (f) all conductors for lampholder, ballasts, control devices, and other accessories intended to be provided with the luminaire shall be installed; and

(g) through-wiring branch circuit conductors as determined by the luminaire marking are installed using wire connectors of the appropriate type and size.

6.16.5 The covers shall be installed as intended without damage to the conductors, wire connectors, and other accessories.

## **6.17 Separation of circuits**

### **6.17.1 Factory installed wiring**

6.17.1.1 Factory-installed power limited wiring and branch circuit wiring that come in random contact within the luminaire shall have insulation rated for the maximum voltage that exists in any of the circuits.

### **6.17.2 Field-installed wiring**

6.17.2.1 Luminaires designed for the field installation of power limited circuits shall be provided with a means of segregating or separating the field-installed power limited circuit wiring from the branch circuit wiring within the luminaire.

6.17.2.2 Power limited circuit wiring and the branch circuit wiring in the same wiring compartment shall be permanently separated a minimum 6.4 mm (0.250 in) by:

- (a) separate entries for field-installed branch circuit wiring and power limited wiring, and
- (b) reliable routing of the conductors within the luminaire; or
- (c) barriers that comply with Clauses 6.17.2.3 and 6.17.2.4.

6.17.2.3 A barrier used to separate power limited wiring from branch circuit wiring in a field wiring compartment shall be made of:

- (a) minimum 0.4 mm (0.016 in) thick metal bonded to other grounded parts of the luminaire;
- (b) minimum 0.7 mm (0.028 in) vulcanized fiber; or
- (c) minimum 0.7 mm (0.028 in) molded polymeric material with a temperature rating suitable for the temperature involved.

6.17.2.4 The width of an opening between a barrier and adjacent parts of the luminaire that separate power limited wiring from branch circuit wiring shall not exceed 1.6 mm (0.063 in). This dimension shall be measured between the barrier and the enclosure walls, components, or the like that serve as part of the compartment.

## 6.18 (MEX) Wire splices and connections

6.18.1 (MEX) In Mexico, every wire splice shall be protected with glass, marble, ceramic material, or polymeric composition and shall also be accessible for maintenance and inspection.

6.18.2 (MEX) In Mexico, a wire splice shall be mechanically and electrically secure and shall be soldered unless a suitable connector is used that has insulation with a maximum operating temperature in accordance with Table 14.12.2 (MEX).

## 7 Incandescent luminaires – supplementary requirements

### 7.1 General

7.1.1 The requirements in Clause 7 are supplementary to other applicable requirements in this Standard.

7.1.2 A luminaire shall be marked, in a location visible during relamping, with a caution, the maximum lamp wattage, and the lamp type, in accordance with Table 20.1.1, Items 3.17 and 3.1.

7.1.2 (CAN) In Canada, the caution marking of Table 20.1.1, Item 3.17, is not required.

7.1.3 More than one lamp wattage and lamp type, as applicable, may be included in the lamp replacement marking if sufficient testing is conducted to confirm that the temperature requirements are met.

7.1.4 An incandescent luminaire intended for connection to other than a nominal 120 V circuit shall be marked with the input line voltage in accordance with Table 20.1.1, Item 1.4.

### 7.2 Temperature test-exempt luminaires

#### 7.2.1 General

7.2.1.1 An incandescent luminaire that complies with Clause 7.2 is exempt from the normal temperature tests of Clause 14 but shall comply with all other applicable test requirements and the factory production tests of Clause 18.

7.2.1.2 The following incandescent luminaires are not temperature test exempt:

- (a) recessed luminaires;
- (b) luminaires intended for mounting in environmental air-handling spaces, recreational vehicles, or exhaust ducts and hoods;
- (c) luminaires intended for operation in elevated ambient temperature;
- (d) luminaires provided with polymeric enclosures, barriers, water shields, or structural parts;
- (e) luminaires employing tungsten-halogen lamps;
- (f) luminaires employing a lamp compartment having more lampholders than the number permitted in Table 7.2.1.1 or a lamp wattage greater than permitted in Table 7.2.1.2; and
- (g) wet location luminaires with gaskets or bushings.

7.2.1.3 The maximum number of lampholders and wattage of lamps shall be in accordance with Tables 7.2.1.1 and 7.2.1.2.

7.2.1.4 The lamp compartment of a pendant ceiling-mounted, surface wall-mounted, pole-mounted, or post-mounted luminaire shall be defined by one of the lamp compartment definitions shown in Figure 7.2.1.1.

**Table 7.2.1.1**  
**Maximum number of lampholders permitted in a lamp compartment**

(See Clauses 7.2.1.2 and 7.2.1.3.)

Luminaire type	Lampholder type	Lamp compartment			
		Exposed	Ventilated	Partially enclosed	Enclosed
Pendant ceiling-mounted	Candelabra	No limit	No limit	3	3
	Intermediate Medium	No limit	3	3	3
Surface ceiling-mounted	Candelabra	Note (1)	N/A	2	1
	Intermediate Medium	Note (1)	N/A	2	1
Surface ceiling-mounted, bullet shade	Candelabra	N/A	N/A	Note (2)	N/A
	Intermediate Medium	N/A	N/A	Note (2)	N/A
Surface wall-mounted	Candelabra	No limit	No limit	3	3
	Intermediate Medium	No limit	3	3	3
Pole-mounted and post mounted	Candelabra	No limit	No limit	3	3
	Intermediate Medium	No limit	3	3	3

NOTES  
 (1) If the lamp is in a vertical, base-up position, one lampholder or a single row of multiple lampholders is permitted, spaced 150 mm (6 in) center-to-center.  
 If the lamp is in a horizontal position, two lampholders maximum are permitted.  
 (2) Multiple lampholders are permitted, each with a bullet shade.  
 N/A Not applicable.

**Table 7.2.1.2**  
**Maximum lamp wattage permitted in a lamp compartment**

(See Clauses 7.2.1.2 and 7.2.1.3.)

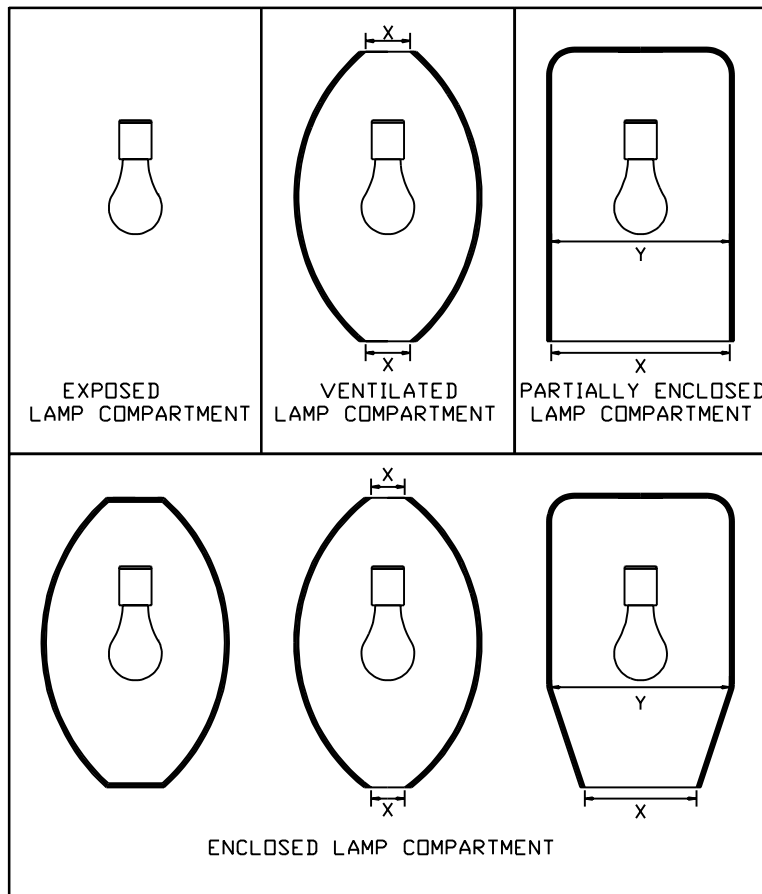
Luminaire type	Lampholder type	Lamp compartment			
		Exposed	Ventilated	Partially enclosed	Enclosed
Pendant ceiling-mounted	Candelabra	60 W per lamp	60 W per lamp	60 W per lamp	60 W per lamp
	Intermediate	40 W per lamp	40 W per lamp	40 W per lamp	40 W per lamp
	Medium	300 W per lamp	450 W per compartment	450 W per compartment	450 W per compartment
Surface ceiling-mounted	Candelabra	40 W per lamp	N/A	40 W per lamp	40 W per lamp
	Intermediate	40 W per Lamp	N/A	40 W per Lamp	40 W per Lamp
	Medium	60 W per lamp	N/A	60 W per lamp	60 W per lamp
Surface ceiling-mounted, bullet shade	Candelabra	N/A	N/A	60 W per lamp	N/A
	Intermediate	N/A	N/A	Note (1)	N/A
	Medium	N/A	N/A	Note (1)	N/A

Table 7.2.1.2 Continued on Next Page

Table 7.2.1.2 Continued

Luminaire type	Lampholder type	Lamp compartment			
		Exposed	Ventilated	Partially enclosed	Enclosed
Surface wall-mounted	Candelabra	60 W per lamp	60 W per lamp	60 W per lamp	60 W per lamp
	Intermediate	40 W per lamp	40 W per lamp	40 W per lamp	40 W per lamp
	Medium	300 W per lamp	450 W per compartment	450 W per compartment	450 W per compartment
Pole-mounted and post-mounted	Candelabra	60 W per lamp	60 W per lamp	60 W per lamp	60 W per lamp
	Intermediate	40 W per lamp	40 W per lamp	40 W per lamp	40 W per lamp
	Medium	300 W per lamp	450 W per compartment	450 W per compartment	450 W per compartment
NOTE Maximum 150 W reflector type, or 100 W for any other type.					
N/A Not applicable.					

**Figure 7.2.1.1**  
**Temperature-test-exempt lamp compartment definitions**  
 (See Clause 7.2.1.4.)



S3818A

Legend:

X is an open area.

Y is the maximum horizontal inside cross-sectional area of the lamp compartment.

EXPOSED LAMP COMPARTMENT has no enclosure or barrier to restrict the flow of air or heat radiation.

VENTILATED LAMP COMPARTMENT has an open area, X, above and below the lamp. Each area, X, is at least 19.3 cm<sup>2</sup> (3 in<sup>2</sup>) for each lamp in the compartment.

PARTIALLY ENCLOSED LAMP COMPARTMENT has an open area, X, above or below the lamp that is at least equal to the maximum horizontal cross-sectional area of the compartment, Y.

ENCLOSED LAMP COMPARTMENT has no ventilation openings and no open area, X, that is less than 19.3 cm<sup>2</sup> (3 in<sup>2</sup>) for each lamp in the lamp compartment or that is less than the maximum cross-sectional area of the compartment, Y.

7.2.1.5 The lamp compartment of a surface ceiling-mounted luminaire shall comply with the requirements of Clause 7.2.5.

7.2.1.6 The dimensions described in Clause 7.2.2 and 7.2.3 shall be measured using the following screwbase lamps:

- (a) medium base, 60 W A19;
- (b) intermediate base, 25 W T8; or
- (c) candelabra base, G16-1/2.

7.2.2 Conductors integral to the luminaire

7.2.2.1 A conductor spaced:

- (a) 50 mm (2 in) or less from a lamp or lampholder shall have a minimum insulation rating of 150 °C, unless otherwise specified in Clause 7.2.2.2 or 7.2.2.3, in which case the lowest conductor insulation rating specified may be used; or
- (b) more than 50 mm (2 in) from a lamp or lampholder shall have a minimum insulation rating of 60 °C.

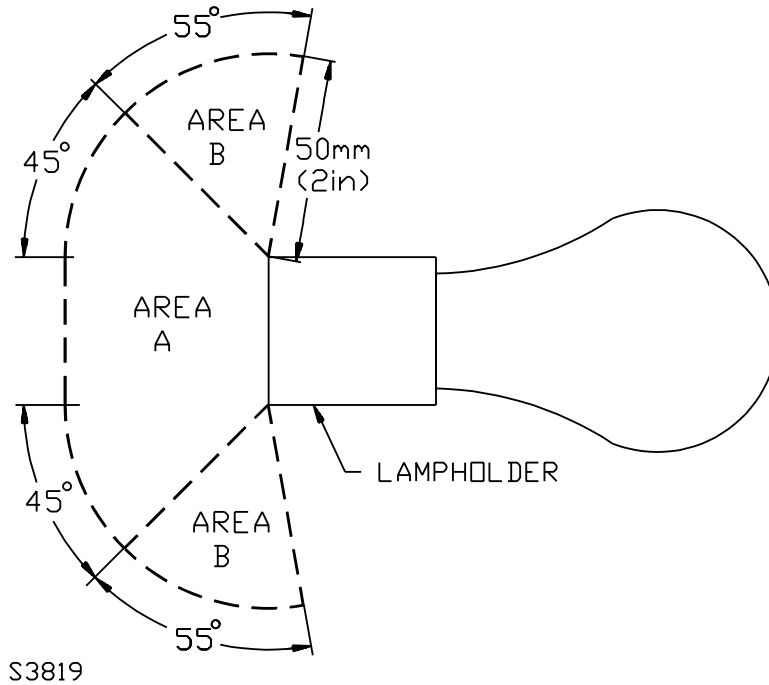
7.2.2.2 A conductor shall have an minimum insulation temperature rating of 75 °C when there is a solid metal barrier between the conductor and the lamp or lampholder and the barrier is spaced a minimum of:

- (a) 38 mm (1.5 in) from the lamp or lampholder; or
- (b) 25 mm (1 in) from the lamp or lampholder, and the conductor is secured to prevent contact with the barrier.

7.2.2.3 A conductor located in areas A or B as shown in Figure 7.2.2.1 shall be rated as shown in Table 7.2.2.1.

**Figure 7.2.2.1**  
**Area for minimum temperature rating of conductors**

(See Clauses 7.2.2.3 and 7.2.3.6.)



**Table 7.2.2.1**  
**Minimum temperature rating of conductor in °C**

(See Clauses 7.2.2.3 and 7.2.3.6.)

Lamp compartment	Position of lamp base	Areas in Figure 7.2.2.1			
		Area A		Area B	
		Total lamp compartment, W		Total lamp compartment, W	
		60 W or less	61 to 450 W	60 W or less	61 to 450 W
Exposed	Base down vertical ±44 degrees	60	60	60	60
	Any other base position	75	75	75	75
Ventilated	Base down vertical ±44 degrees	60	75	75	75
	Any other base position	90	105	90	105
Partially enclosed	Base down vertical ±29 degrees	60	75	75	90
	Base horizontal +61 degrees, -15 degrees	75	90	90	105
	Any other position	90	105	105	150
Enclosed	Base down vertical ±44 degrees	75	90	75	90
	Any other base position	105	150	150	150

### 7.2.3 Branch circuit conductor insulation temperature ratings

7.2.3.1 A luminaire shall be marked with a minimum branch circuit temperature rating equal to or greater than the lowest insulation temperature rating permitted in Clauses 7.2.3.2 to 7.2.3.6 for any type luminaire. Clause 7.2.3.6 applies to wall-mounted luminaires only.

7.2.3.2 A luminaire construction that permits a branch circuit conductor, assumed to be 150 mm (6 in) long, measured from the center of the outlet box face or luminaire conduit connection point, to come within 50 mm (2 in) of a lamp or lampholder shall be marked for branch circuit conductors with a minimum insulation temperature rating of 150 °C in accordance with Table 20.1.1, Item 1.1, and not for use in dwellings in accordance with Item 2.5, unless otherwise specified in Clauses 7.2.3.3, 7.2.3.4, or 7.2.3.5.

7.2.3.3 A luminaire construction that prevents the branch circuit conductors, assumed to be 150 mm (6 in) long, measured from the center of the outlet box face or luminaire conduit connection point, from coming within 50 mm (2 in) of a lamp or lampholder shall be permitted to be connected to branch circuit conductors with a minimum insulation temperature rating of 60 °C in accordance with Table 20.1.1, Item 1.1, unless otherwise specified in Clause 7.2.3.4 or 7.2.3.5.

7.2.3.4 A luminaire that provides a solid metal barrier between any lamp or lampholder and any branch circuit conductor, assumed to be 150 mm (6 in) long, measured from the center of the outlet box face or conduit connection point, shall be marked for branch circuit conductors with a minimum insulation temperature rating of 75 °C in accordance with Table 20.1.1, Item 1.1, provided that the barrier is spaced a minimum of:

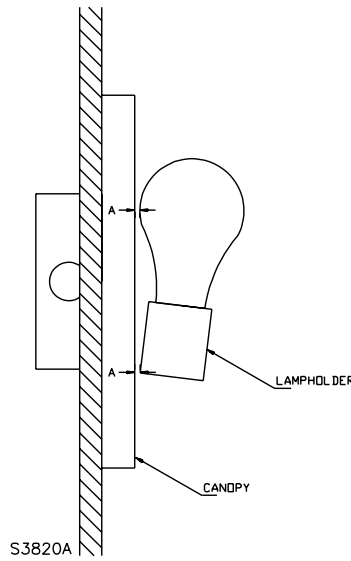
- (a) 38 mm (1.5 in) from the lamp or lampholder; or
- (b) 25 mm (1 in) from the lamp or lampholder, and the conductor is routed to prevent contact with the barrier.

7.2.3.5 A luminaire that permits a branch circuit conductor to be located in areas A or B as shown in Figure 7.2.2.1 shall be marked in accordance with Table 20.1.1, Item 1.1, with the appropriate insulation temperature rating as specified in Table 7.2.2.1.

7.2.3.6 A wall-mounted luminaire shall have the outside surface of the canopy located at least 3.2 mm (0.125 in) from the lamp envelope and lampholder (see dimension A of Figure 7.2.3.1) and shall be marked to indicate the branch circuit temperature rating in accordance with Table 7.2.3.1 and be in accordance with marking requirements of Clause 10.6.9 (USA) and 10.6.9 (CAN).

**Figure 7.2.3.1**  
**Minimum lamp spacings for wall-mounted luminaires**

(See Clauses 7.2.3.6 and 7.2.5.7.)



Note: Dimension A is minimum 3.2 mm (0.125 in).

**Table 7.2.3.1**  
**Minimum temperature ratings of branch circuit conductors for wall-mounted luminaires**

(See Clause 7.2.3.6.)

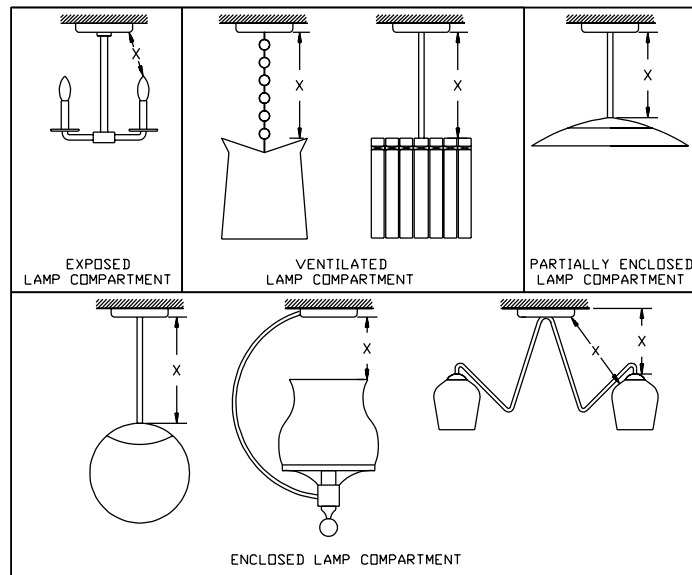
Lamp compartment	Maximum lamp compartment wattage	Allowable branch circuit temperature, °C
Exposed	150	60
Ventilated	100	60
	200	75
	300	90
Partially enclosed	75	75
	100	90
Enclosed	60	75
	75	90

## 7.2.4 Pendant ceiling-mounted luminaires

7.2.4.1 A free air space (see dimension X of Figure 7.2.4.1) of at least 100 mm (4 in) shall exist between a lamp or lamp compartment of a pendant luminaire and the ceiling or canopy it is mounted to when the luminaire is installed as intended. A pendant luminaire with a free air space less than 100 mm (4 in) shall comply with the requirements for a surface ceiling-mounted luminaire of Clause 7.2.5 to be considered test exempt.

**Figure 7.2.4.1**  
Temperature-test-exempt pendant luminaires

(See Clause 7.2.4.1.)



Note: Dimension X is minimum 100 mm (4 in)

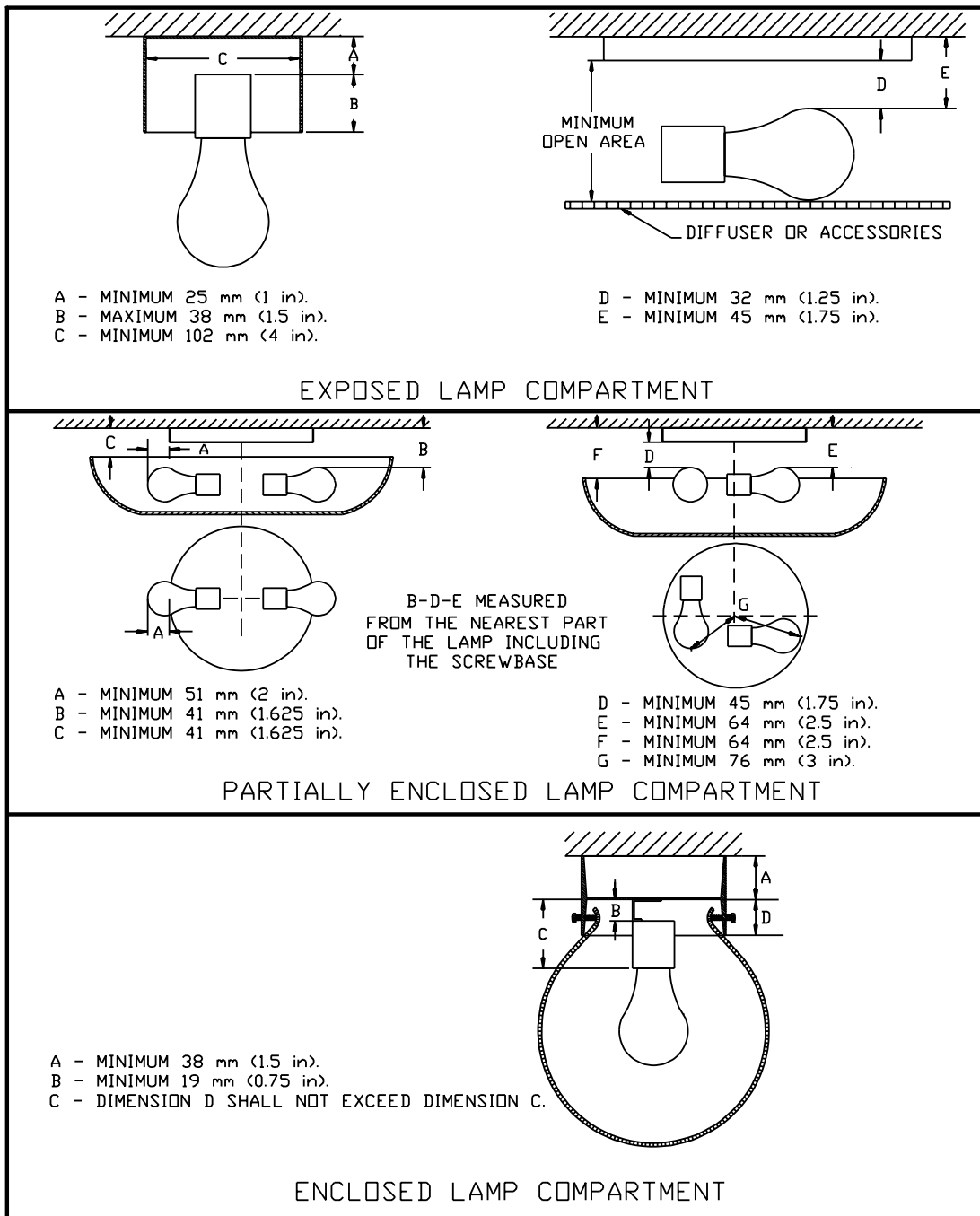
S3821

## 7.2.5 Surface ceiling-mounted luminaires

7.2.5.1 The general design and dimensions of a surface ceiling-mounted luminaire shall be as shown in Figure 7.2.5.1.

**Figure 7.2.5.1**  
**Temperature-test-exempt surface ceiling-mounted luminaires**

(See Clauses 7.2.5.1, 7.2.5.2, 7.2.5.3, 7.2.5.4, 7.2.5.5, and 7.2.5.7)



S3822

NOTE Dimensions measured using lamps in accordance with Clause 7.2.5.7.

7.2.5.2 The luminaires shown in Figure 7.2.5.1 shall be marked either caution, maximum 40 W for intermediate and candelabra base lamps, or caution, maximum 60 W for medium base lamps, in accordance with Table 20.1.1, Items 3.17 and 3.1.

7.2.5.2 (CAN) In Canada, the caution marking of Table 20.1.1, Item 3.17, shall not be required.

7.2.5.3 An exposed lamp compartment luminaire as shown in Figure 7.2.5.1 shall have no provision such as threaded canopies, clips, or thumbscrews to attach husks, diffusers, globes, shades, or other parts that can entrap heat.

7.2.5.4 A partially enclosed lamp compartment as shown in Figure 7.2.5.1 shall be exposed at the top, with no glassware or other material partially or completely enclosing the area above the lamps.

7.2.5.5 A luminaire shown in Figure 7.2.5.1 shall be provided with thermal insulation that completely closes off the opening to the outlet box at the ceiling line. The thermal insulation shall comply with Clause 5.18.5.

7.2.5.6 A conductor integral to a surface ceiling-mounted luminaire shall be rated at least 150 °C.

7.2.5.7 The dimensions described in Figures 7.2.3.1 and 7.2.5.1 shall be measured using the following screwbase lamps:

- (a) medium base, 60 W A19;
- (b) intermediate base, 25 W T8; or
- (c) candelabra base, G16-1/2.

#### 7.2.6 Surface ceiling-mounted luminaires – bullet shade

7.2.6.1 A luminaire shown in Figure 7.2.6.1 is considered to include a partially enclosed lamp compartment and shall be marked caution, maximum 150 W when used with a reflector-type lamp, or caution, maximum 100 W for other lamp types, in accordance with Table 20.1.1, Items 3.17 and 3.1.

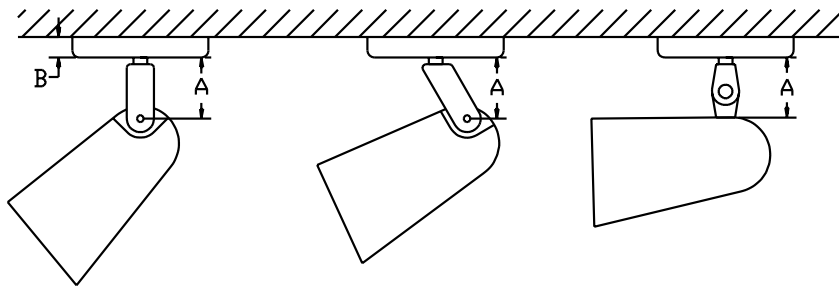
7.2.6.1 (CAN) In Canada, the caution marking of Table 20.1.1, Item 3.17, shall not be required.

7.2.6.2 A luminaire shown in Figure 7.2.6.1 shall be provided with a mechanical means to prevent it from being aimed at or directed above the horizontal towards the ceiling or canopy, and the back of the shade shall have no open holes.

7.2.6.3 A luminaire shown in Figure 7.2.6.1 shall be provided with thermal insulation that completely closes off the opening to the outlet box at the ceiling line. The thermal insulation shall comply with Clause 5.18.5.

**Figure 7.2.6.1**  
**Temperature-test-exempt bullet shade luminaires**

(See Clauses 7.2.6.1 to 7.2.6.3.)



**Notes:**

- A – Minimum 25 mm (1 in) from bottom of canopy to point where swivel joint enters shade.
- B – Minimum 19 mm (0.75 in).

S3823

### 7.2.7 Surface wall-mounted luminaires

7.2.7.1 A luminaire that appears to be made so that it can be mounted either to a ceiling or wall and that does not comply with the requirements of Clause 7.2.5 or 7.2.6 shall be marked for wall mounting only, in accordance with Table 20.1.1, Item 2.10.

7.2.7.2 A luminaire construction that permanently spaces the lamp or lampholder 50 mm (2 in) or more from the back plane of the luminaire canopy or from the edge of the outlet box on which it is mounted may have a minimum branch circuit conductor insulation temperature rating of 60 °C when the luminaire is marked to push the conductors into the outlet box, in accordance with Table 20.1.1, Item 1.25.

## 7.3 Tungsten-halogen luminaires

### 7.3.1 Lamp containment barriers

7.3.1.1 A luminaire employing tungsten-halogen lamps as the primary light source shall be provided with a lamp containment barrier that will contain major particles resulting from a ruptured lamp, unless:

- (a) the lamp manufacturer declares on the lamp package that the lamp is suitable for use in an open luminaire; or
- (b) the luminaire is intended to be used with a lamp provided with an integral outer lamp envelope, and the lamp manufacturer does not provide a caution requiring an additional lamp containment barrier.

7.3.1.2 A luminaire employing a tungsten-halogen lamp that does not require an additional lamp containment barrier may be provided with a lamp containment barrier or shall be:

- (a) marked with a caution, the maximum lamp wattage, and the type of shielded lamp, in accordance with Table 20.1.1, Items 3.1, 3.17 and 3.2; or
- (b) marked with a caution, the maximum lamp wattage, the type of shielded lamp, and the lamp replacement requirements in accordance with Table 20.1.1, Items 3.1, 3.17, and 3.20. Additionally, the luminaire may be marked with the symbol shown in Figure D.4, if the luminaire is provided with instructions in accordance with Table 20.1.1, Item 1.33, that explain that the symbol on the lamp package is an indication that the lamp does not require additional shielding.

7.3.1.2 (CAN) In Canada, the caution marking of Table 20.1.1, Item 3.17, shall not be required.

7.3.1.3 A lamp containment barrier shall be secured in position by one of the following methods:

- (a) mechanical means that produces an interference fit;
- (b) physical fit; or
- (c) other similar means.

7.3.1.4 A luminaire with a removable lamp containment barrier that is required to be removed during user maintenance shall be marked to keep the barrier in place, in accordance with Table 20.1.1, Item 3.12.

7.3.1.4 (USA) In the United States, the barrier marking of Table 20.1.1, Item 3.12, is not required.

7.3.1.5 Open holes in a lamp containment barrier that are located at points where particles from a ruptured lamp are likely to drop and rest or that provide a direct line of sight to the filament from the outside the luminaire shall not permit the passage of a 3.3 mm (0.130 in) diameter rod.

7.3.1.6 A lamp containment barrier shall be constructed of the following materials:

- (a) ceramic;
- (b) glass in accordance with Clause 7.3.1.7;
- (c) metal screen;

- (d) metal having minimum thickness of 0.41 mm (0.016 in); or
- (e) polymeric material in compliance with Clause 7.3.1.8.

7.3.1.7 The part of a glass containment barrier where particles from a ruptured lamp are likely to drop and rest shall have a minimum thickness of:

- (a) 2.4 mm (0.095 in) for luminaires rated less than 100 W; and
- (b) 3.0 mm (0.118 in) for luminaires rated for 100 W or more.

7.3.1.8 A polymeric lamp containment barrier, where particles from a ruptured lamp are likely to drop and rest, shall comply with the lamp containment barrier melt-through test of Clause 16.29 or the five-inch flame test of Clause 16.3.

### 7.3.2 Accessibility of double-ended lamp terminals

7.3.2.1 Lamp terminals of a double-ended tungsten-halogen lamp shall not be accessible during relamping unless:

- (a) all ungrounded circuit conductors are disconnected by an interlock switch before the parts become accessible; or
- (b) the supply circuit has one grounded conductor, and the lamp terminals can only make initial contact with the grounded lampholder terminal; or
- (c) the supply circuit has one grounded conductor, and in order to be fully installed the lamp is required to be inserted into the grounded lampholder terminal first. The luminaire shall be marked adjacent to the lampholder connected to the grounded (neutral) supply connection with a caution and to indicate insertion of the lamp in this lampholder first, in accordance with Table 20.1.1, Items 3.18 and 3.10.

7.3.2.1 (CAN) In Canada, the caution marking of Table 20.1.1, Item 3.18, shall not be required.

7.3.2.2 An interlock switch shall comply with the interlock switch endurance test of Clause 17.3.

7.3.2.3 A luminaire employing a double-ended tungsten-halogen lamp without an interlock switch shall be marked with a caution and to disconnect power before servicing in accordance with Table 20.1.1, Items 3.18 and 3.6.

7.3.2.3 (CAN) In Canada, the caution marking of Table 20.1.1, Item 3.18, shall not be required.

7.3.2.4 A disconnect switch provided on a luminaire shall disconnect all ungrounded supply conductors, and the OFF position shall be marked on or adjacent to the switch.

### 7.3.3 Tungsten-halogen lamp voltage incompatibility

7.3.3.1 The requirements in Clause 7.3.3 apply to a luminaire employing a tungsten-halogen lamp as the primary light source, and are not intended to cover auxiliary light sources within the same luminaire. These requirements shall not apply to photographic equipment with internal tungsten-halogen lamps.


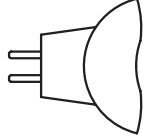
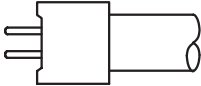
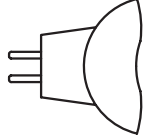

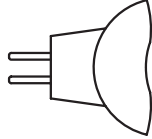
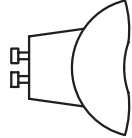
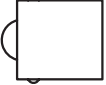
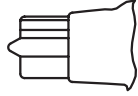
7.3.3.2 The lampholder voltage for a luminaire employing a lamp with a lamp base configuration shown in Table 7.3.3.1 shall be 30 V rms, 42.4 V peak, or less, regardless of the nominal luminaire input voltage.

7.3.3.3 The lampholder voltage for a luminaire employing a lamp with a lamp base configuration shown in Table 7.3.3.2 shall be a nominal operating voltage of 120 V.

7.3.3.4 An adapter shall not be provided to convert a luminaire employing a lamp with a lamp base configuration shown in Table 7.3.3.2 (for use at a nominal operating voltage of 120 V) to accommodate a lamp with a lamp base configuration shown in Table 7.3.3.1 (for use at 30 V rms, 42.4 V peak, or less) unless the adapter is provided with an integral, isolated, step-down transformer or voltage converter.

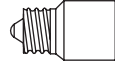







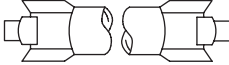
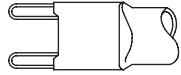
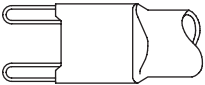
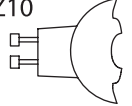
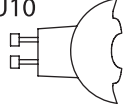
**Table 7.3.3.1**  
**Lamp base configuration, 30 V rms, 42.4 V peak, or less**

(See Clauses 7.3.3.2 and 7.3.3.4.)

Description	Lamp Base	Lamp Base Physical Shape
Bipin C-C 4 mm (0.157 in)	G4	
Bipin C-C 4 mm (0.157 in)	GU4	
Bipin C-C 5.3 mm (0.209 in)	G5.3	
Bipin C-C 5.3 mm (0.209 in)	GU5.3 GX5.3 GY5.3	
Bipin C-C 6.35 mm (0.250 in)	G6.35 GX6.35 GY6.35	
Bipin C-C 6.35 mm (0.250 in)	GZ6.35	
Bipin C-C 7 mm (0.275 in) Twist and Lock	GU7	
Single Contact Bayonet Candelabra	BA15S	
Wedge	W2.1 x 9.5d	

**Table 7.3.3.2**  
**Lamp base configurations, 120 V nominal**

(See Clauses 7.3.3.3 and 7.3.3.4.)

Description	Lamp Base	Lamp Base Physical Shape	
Mini-Can Screw	E11		
Candelabra	E12		
Intermediate	E17		
Medium	E26/24		
Medium Skirted	E26/50X39		
Trilite	E26d		
Mogul	E39		
Double-ended	R7S		
Double-ended	RX7S		
Bi-pin C – C 8 mm (0.315 in)	G8		
Bi-pin C – C 9 mm (0.354 in)	G9		
Bi-pin C – C 10 mm (0.394 in) Twist and lock	GZ10 GU10		

SM1385N

## 8 Fluorescent luminaires – supplementary requirements

### 8.1 General

8.1.1 The requirements in Clause 8 are supplementary to other applicable requirements in this Standard.

### 8.2 Ballasts

8.2.1 A fluorescent luminaire shall use a thermally protected ballast, except that a non-thermally protected simple reactance ballast may be used:

- (a) with straight tubular lamps; or
- (b) when the luminaire is marked for outdoor use only, in accordance with Table 20.1.1, Item 2.4.

8.2.2 A luminaire designed for use with a remotely mounted ballast shall meet the following requirements:

- (a) it shall be provided with means for connection of the ballast using one of the power supply connections described in Clause 6.15.
- (b) it shall not employ single-pins type lampholders.

### 8.3 Supply cords and conductors

8.3.1 When the supply cord of a luminaire permits the cord to be pushed back into the enclosure, resulting in a spacing between the cord and the ballast of less than 76 mm (3 in), the supply cord shall be rated for at least 90 °C or for the temperature of any component it can contact, whichever is greater.

8.3.2 Conductors shall have a minimum temperature rating in accordance with Table 8.3.1 or the temperature measured during the normal temperature test of Clause 14.

**Table 8.3.1**  
**Minimum temperature rating of conductors**

(See Clauses 8.3.2 and 8.5.2.)

Position of conductors relative to ballasts	Temperature °C
Permanently spaced a minimum of 76 mm (3 in) from any ballast	60
Less than 76 mm (3 in) from, but not in contact with, any ballast except at the point of entry to the ballast	80
In contact with any ballast or spaced less than 76 mm (3 in) and provided with an outer braid	75
In contact with any ballast or spaced less than 76 mm (3 in)	90

8.3.3 A recessed fluorescent luminaire shall not be provided with flexible cord for connection to the supply.

8.3.3 (CAN) In Canada, the supply cord of a cord- and plug-connected recessed fluorescent luminaire intended for installation in an accessible suspended ceiling shall be:

- (a) a hard-usage type for a system voltage up to 300 V, or an extra-hard-usage type for a system voltage up to 600 V;
- (b) no longer than 3 m (10 ft);
- (c) fitted with an attachment plug; and
- (d) of a minimum temperature rating of 90 °C.

## 8.4 Lampholders

8.4.1 Lampholders shall be of a type and voltage rating suitable for the lamp and ballast intended to be used.

8.4.2 Lampholders of the bipin, miniature, medium, or mogul size shall have a voltage rating greater than the output voltage or voltage to ground, if marked on the ballast.

8.4.3 The voltage rating of lampholders intended for use with a simple reactance ballast shall be greater than the supply voltage.

8.4.4 Circuit-interrupting-type lampholders required by the ballast marking shall be connected in accordance with the ballast wiring diagram.

8.4.5 Lampholders of the single pin, slimline type shall have the circuit-interrupting mechanism in the stationary lampholder.

8.4.6 Lampholders of the circuit-interrupting type shall be connected in the line side of the ballast and have a voltage rating greater than the supply voltage.

8.4.7 The lampholders connected to the high voltage ballast conductors shall be rated:

- (a) 600 V minimum; or
- (b) 250 V and provided with a supplementary insulation consisting of 0.4 mm (0.016 in) thick material of fiber or phenolic composition; or
- (c) 250 V and provided with a 2 mm (0.078 in) permanent air space between the back of the lampholder and the metal of the luminaire.

8.4.8 Lampholders intended for use with HO (800 mA) and VHO (1500 mA) lamps shall be the recessed double contact type.

## 8.5 Temperature-test-exempt luminaires

8.5.1 A luminaire that complies with the applicable requirements of Clause 8.5 is exempt from the normal temperature test of Clause 14 and the abnormal temperature test of Clause 15.

8.5.2 The following constructions are not temperature test exempt:

- (a) Type IC recessed luminaires;
- (b) luminaires intended for mounting in non-residential exhaust ducts and hoods above cooking equipment;
- (c) luminaires intended for operation in elevated ambient temperature;
- (d) luminaires provided with polymeric enclosures or water shields with a mechanical temperature rating less than 105 °C;
- (e) luminaires marked for through wiring that do not comply with Clause 8.5.3;
- (f) luminaires employing more than one ballast spaced less than 25 mm (1 in) end to end or 100 mm (4 in) side to side;
- (g) luminaires with wire whose insulation temperature rating does not comply with Table 8.3.1;
- (h) luminaires provided with a non-thermally-protected ballast, rated for use with single-ended fluorescent lamps;
- (i) wet locations luminaires with gaskets or bushings;
- (j) luminaires provided with a thermally protected ballast located less than 75 mm (3 in) from a knockout or other power supply entry, unless the luminaire is marked for 90 °C supply conductors in accordance with Table 20.1.1, Item 1.1; and
- (k) luminaires employing single-ended fluorescent lamps.

8.5.2 (USA) In the United States, luminaires employing single-ended fluorescent lamps and thermally protected ballasts shall be temperature test exempt.

8.5.3 A luminaire intended for use with through wiring is temperature test exempt under the following conditions:

- (a) the wiring compartment is at least 13 mm (0.5 in) from the recessed housing; and
- (b) there are no other heat-producing components mounted on or in the wiring compartment.

## 8.6 Marking

8.6.1 Instead of the current rating in amperes, as required by Clause 20.2.3, a luminaire employing:

- (a) a high-power-factor, reactor-type ballast or ballasts for bipin lamps (preheat or rapid start types) may be marked in accordance with Table 20.1.1, Item 1.27;
- (b) a low-power-factor, reactor-type ballast or ballasts for bipin lamps may be marked in accordance with Table 20.1.1, Item 1.28; or
- (c) single-pin lamps (instant start type) and high-power-factor ballast or ballasts may be marked in accordance with Table 20.1.1, Item 1.29, using the multiplying factors shown in Table 8.6.1.

**Table 8.6.1**  
**Multiplying factors for ballasts**

(See Clause 8.6.1.)

Maximum ballast output current in milliamperes	Minimum acceptable multiplying factor
120 or less	0.6
121 – 200	0.8
210 – 300	1.2
301 – 460	1.5

8.6.2 A luminaire intended for use with an adapter plate and shipped without the adapter shall be marked to indicate the plate, in accordance with Table 20.1.1, Items 4.1 and 4.2.

8.6.3 A luminaire designed for use with a remote ballast shall be marked to indicate that the intended ballast is thermally protected, in accordance with Table 20.1.1, Item 1.30.

8.6.4 A luminaire designed for use with single-ended, compact fluorescent lamps and having non-thermally protected ballasts shall be marked to indicate the lamps intended, in accordance with Table 20.1.1, Item 3.21.

8.6.5 A luminaire designed for use with germicidal lamps shall be marked to warn the user of the dangers of exposure of the eye and bare skin to UV radiation, in accordance with Table 20.1.1, Items 3.19 and 4.7.

## 8.7 Emergency battery packs

8.7.1 A luminaire provided with a factory-installed listed or certified emergency battery pack shall be:

- (a) installed in accordance with the installation instructions marked on or provided with the pack; and
- (b) marked to indicate emergency backup in accordance with Table 20.1.1, Item 1.42.

## 8.8 Luminaires incorporating instant-start electronic ballasts and bi-pin lampholders

8.8.1 A luminaire with instant-start ballast(s), incorporating bi-pin lampholders shall:

- (a) be constructed with a ballast(s) identified as Type CC, or
- (b) be constructed with lampholders intended for use with instant-start electronic ballasts in accordance with Clause 4.1. Lampholders marked with a circle "I" comply with these requirements.

## 8.9 (CAN) Branch circuit disconnects

8.9.1 (CAN) In Canada, each fluorescent luminaire provided with ballasts intended for installation on branch circuits with voltages exceeding 150 volts to ground, including multi-voltage ballasts such as 120-277 V, shall be provided with one or more installed disconnect means that:

- (a) complies with Clause 8.9.2 (CAN);
- (b) simultaneously opens all circuit conductors between the branch circuit conductors and one or more ballast(s); and
- (c) are marked according to their specific locations, with the marking located and worded according to (i) or (ii), as follows:
  - (i) when the disconnect means is installed inside the luminaire, the marking shall be located adjacent to such means and shall be worded in accordance with Table 20.1.1, Item 3.24.
  - (ii) when the disconnect means is installed outside the luminaire and not accessible from the room side, the marking shall be located adjacent to the ballast and shall be worded in accordance with Table 20.1.1, Item 3.25.

8.9.2 (CAN) In Canada, an acceptable disconnect means shall consist of one or more of the following:

- (a) a mating connector with a current-interrupting rating and voltage rating suitable for the ballast(s) employed in the luminaire;
- (b) a multi-pole switch that opens all circuit conductors simultaneously and is rated in accordance with Clause 6.4.1.1;
- (c) a wiring harness that is considered suitable for this application;
- (d) a cord set or power supply cord; or

- (e) a ballast provided with an integral disconnect means that complies with Clause 8.9.2 (CAN) (a), and with Clause 6.13.1.1 with regard to the accessibility of live parts.

8.9.3 (CAN) In Canada, each fluorescent luminaire intended to be installed on branch circuits with voltages exceeding 150 volts to ground and designed for use with remote ballasts, including multi-voltage ballasts such as 120-277 V, shall be provided with a disconnect means that complies with Clause 8.9.2 (CAN), at the ballast location.

8.9.4 (CAN) In Canada, luminaires complying with Clause 8.7 are not required to be provided with disconnect means when marked in accordance with Table 20.1.1, Items 3.27 and 3.28.

## **8.10 (CAN) Branch circuit disconnects — Conversion kits**

8.10.1 (CAN) In Canada, a retrofit conversion kit designed to provide a disconnect means for currently installed fluorescent luminaires shall include:

- (a) a disconnect means that complies with Clause 8.9.2 (CAN);
- (b) instructions that comply with Clause 8.10.2 (CAN);
- (c) twist-on or push-in wire connectors, if supplied as components of the conversion kit, rated for a minimum 600 V; and
- (d) a separate pressure-sensitive label, to be installed during retrofit, that complies with Clause 8.9.1 (CAN) (c).

8.10.2 (CAN) In Canada, each conversion kit shall include the following markings on the smallest packaging unit:

- (a) a heading, in accordance with Table 20.1.1, Item 1.44;
- (b) a caution in accordance with Table 20.1.1, Item 3.26;
- (c) instructions for the intended application and complete details if designed for a specific luminaire or ballast(s) type; and
- (d) instructions regarding the installation of the label required in Clause 8.10.1 (CAN) (d).

## **9 HID luminaires – supplementary requirements**

### **9.1 General**

9.1.1 The requirements in Clause 9 are supplementary to other applicable requirements in this Standard.

## 9.2 Lampholders

9.2.1 A lampholder intended to be used with a lamp that requires high-voltage starting pulses shall have a pulse rating suitable for the lamp starting voltage.

9.2.2 The insulation on the lampholder conductors and the conductors of the output circuit of a ballast that requires high-voltage starting pulses shall be rated a minimum of 600 V.

## 9.3 Lamp containment barriers for metal halide lamps

9.3.1 A luminaire employing a metal halide lamp shall be provided with a lamp containment barrier that can contain major particles resulting from a ruptured lamp, unless:

(a) the luminaire is intended for use with only a Type-O thick-glass parabolic reflector (PAR) lamp. The luminaire shall be marked with a caution, the lamp wattage and an ANSI designation in accordance with Table 20.1.1, Items 3.17, 3.8, and 3.9. The lamp designation in the marking specified in Item 3.8 shall include “/O” following the lamp ANSI electrical code designation to indicate the need to re-lamp with a metal halide Type-O lamp (e.g., M90/O); or

(b) the luminaire is provided with a means that only allows the use of a lamp that is a metal halide Type-O. The luminaire shall be marked with the lamp wattage and an ANSI designation in accordance with Table 20.1.1, Item 3.8. The lamp designation in the marking specified in Item 3.8 shall include “/O” following the lamp ANSI electrical code designation to indicate the need to relamp with a metal halide Type-O lamp (e.g. M155/O).

9.3.2 A lamp containment barrier shall be secured in position.

9.3.3 Open holes in a lamp containment barrier that are located at points where particles from a ruptured lamp are likely to drop and rest or that provide a direct line of sight to the arc tube from outside the luminaire shall not permit the passage of a 3.3 mm (0.130 in) diameter rod.

9.3.4 A lamp containment barrier shall be constructed of the following material:

- (a) ceramic;
- (b) glass;
- (c) metal screen;
- (d) metal having a minimum thickness of 0.41 mm (0.016 in); or
- (e) polymeric material.

9.3.5 The part of a glass containment barrier where particles from a ruptured lamp are likely to drop and rest shall be minimum 3.0 mm (0.118 in) thick.

9.3.6 If the part of a glass containment barrier where particles from a ruptured lamp are likely to drop and rest is not borosilicate or tempered glass, it shall comply with the lamp containment barrier thermal shock test of Clause 16.28.

9.3.7 The part of a polymeric containment barrier where particles from a ruptured lamp are likely to drop and rest shall comply with the lamp containment barrier melt-through test of Clause 16.29 or the five-inch flame test of Clause 16.3.

#### **9.4 Ultra-violet (UV) attenuation barriers for metal halide lamps without integral UV blocking outer glass envelopes**

##### 9.4.1 General

9.4.1.1 A luminaire intended to be used with a metal halide lamp shall:

- (a) be provided with an UV attenuation barrier in accordance with Clauses 9.4.1.2 to 9.4.1.4;
- (b) use a metal halide lamp with a quartz outer envelope that is marked with an ANSI lamp code that includes an "E" or "O" (e.g., M130/E) and be provided with a marking instructing the user to use only a metal halide lamp that is marked with the ANSI lamp code that includes an "E" or "O," identifying it as complying with ANSI C78.380, in accordance with Table 20.1.1, Item 3.22; or
- (c) use a metal halide lamp with a glass outer envelope and marked with an ANSI lamp code that includes an "E" or "O" or "S" (e.g., M135/O), identifying it as complying with ANSI C78.380. The lamp replacement marking shall also include the ANSI lamp code "E" or "O" or "S" as part of the lamp designation in accordance with Table 20.1.1, Item 3.8.

9.4.1.1 (MEX) In Mexico, a luminaire intended to be used with a metal halide lamp shall:

- (a) be provided with an UV attenuation barrier in accordance with Clauses 9.4.1.2 to 9.4.1.4;
- (b) use a metal halide lamp with a quartz outer envelope that is marked with an ANSI lamp code that includes an "E" or "O" (e.g., M130/E) and be provided with a marking instructing the user to use only a metal halide lamp that is marked with the ANSI lamp code that includes an "E" or "O," identifying it as complying with NMX-J-547-ANCE, in accordance with Table C.1 (MEX), Item 3.22; or
- (c) use a metal halide lamp with a glass outer envelope and marked with an ANSI lamp code that includes an "E" or "O" or "S" (e.g., M135/O), identifying it as complying with NMX-J-547-ANCE. The lamp replacement marking shall also include the ANSI Lamp Code "E" or "O" or "S" as part of the lamp designation.

9.4.1.2 An UV attenuation barrier shall be constructed of the following materials:

- (a) glass in accordance with Clause 9.4.2;
- (b) metal; or
- (c) ceramic.

9.4.1.3 A UV attenuation barrier shall not have any open holes that would permit direct viewing of the light source or light that is reflected from only one surface.

9.4.1.4 A luminaire with a UV attenuation barrier shall be provided with an interlock switch in accordance with Clause 6.4.2 to de-energize the lamp when the lamp compartment is opened.

9.4.2 Glass

9.4.2.1 A glass UV attenuation barrier shall be constructed of one of the following:

- (a) soda lime glass having a minimum thickness of 4.0 mm (0.157 in);
- (b) another type of glass that has a minimum thickness of 3.0 mm (0.118 in) and that complies with the ultra-violet transmission requirements specified in Table 9.4.2.1; or
- (c) other types of glass with a minimum thickness of 3.0 mm (0.118 in) if the luminaire, lamp, and attenuation barrier comply with the accepted effective UV power limits described in the ANSI/IESNA RP 27 series of standards; and the luminaire is marked to identify the lamp in accordance with Table 20.1.1, Item 3.23.

**Table 9.4.2.1**  
**UV transmission requirements of glass**

(See Clause 9.4.2.1.)

Wavelength, nm	Maximum transmission percentage
350	85
320	40
300	8
290	0.5
< 290	0.1

9.4.2.2 A UV attenuation barrier shall withstand without fracture a 2.7 J (2 ft·lb) impact using the test apparatus described in Clause 19.21.

9.4.2.3 A UV attenuation barrier used on a ground-mounted recessed luminaire or a luminaire marked as suitable for installation within 1.22 m (4 ft) of the ground shall withstand without fracture a 6.8 J (5 ft·lb) impact using the test apparatus described in Clause 19.21.

## 9.5 Accessibility of double-ended lamp terminals

9.5.1 Lamp terminals of a double-ended HID lamp shall not be accessible during relamping unless:

- (a) all ungrounded circuit conductors are disconnected by an interlock switch before the parts become accessible;
- (b) the supply circuit has one grounded conductor, and the lamp terminals can only make initial contact with the grounded lampholder terminal; or
- (c) the supply circuit has one grounded conductor, and in order to be fully installed the lamp is required to be inserted into the grounded lampholder terminal first. The luminaire shall be marked, adjacent to the lampholder connected to the grounded supply connection, with a caution and with a statement indicating the method of lamp insertion in the lampholder. These markings shall be in accordance with Table 20.1.1, Items 3.18 and 3.10.

9.5.1 (CAN) In Canada, the caution marking of Table 20.1.1, Item 3.18, shall not be required.

9.5.2 An interlock switch shall comply with the interlock switch endurance test of Clause 17.3.

9.5.3 Luminaires employing a double-ended HID lamp without an interlock switch shall be marked with a caution and a warning to disconnect power before servicing, in accordance with Table 20.1.1, Items 3.18 and 3.6.

9.5.3 (CAN) In Canada, the caution marking of Table 20.1.1, Item 3.18, shall not be required.

## 9.6 Marking

9.6.1 An HID luminaire shall be marked with the lamp wattage and lamp designation that coincide with the ballast rating, in accordance with Table 20.1.1, Item 3.8.

9.6.1 (MEX) In Mexico, an HID luminaire shall be marked with the lamp wattage and lamp designation that coincide with the ballast rating, in accordance with Annex C (MEX), Table C.1, Item 3.8.

9.6.2 An HID luminaire using a lamp that does not have an ANSI designation shall be marked with a lamp wattage that coincides with ballast rating and, if applicable, the voltage and lamp type, in accordance with Table 20.1.1, Items 3.14 and 3.16.

9.6.3 More than one lamp wattage and lamp type, as applicable, may be included in the lamp replacement marking if testing is conducted to confirm that the temperature requirements are met.

9.6.4 A luminaire that uses only a low-pressure sodium lamp shall not be required to have a lamp replacement marking.

9.6.5 A luminaire with a removable lamp containment barrier as described in Clause 9.3 that is required to be removed during user maintenance shall be marked to keep the barrier in place, in accordance with Table 20.1.1, Item 3.12.

9.6.6 A luminaire with a removable UV attenuation barrier that is required to be removed during user maintenance shall be marked with a caution and to keep the protective barrier in place or replace removable parts in accordance with Table 20.1.1, Items 3.19 and 3.13.

9.6.6 (CAN) In Canada, the caution marking of Table 20.1.1, Item 3.19, shall not be required.

## **10 Surface-mounted luminaires – supplementary requirements**

### **10.1 General**

10.1.1 The requirements in Clause 10 are supplementary to other applicable requirements in this Standard.

### **10.2 Mounting means**

10.2.1 A luminaire intended to be directly mounted to an outlet box shall be provided with two No. 8-32 machine screws if the luminaire surface containing the mounting screw holes is more than 3.2 mm (0.125 in) from the mounting surface. The length of each screw shall be at least 13 mm (0.5 in) plus the distance from the mounting surface to the luminaire surface that contains the screw holes.

10.2.2 A crossbar intended as the sole support for mounting a luminaire to an outlet box shall be at least 1.35 mm (0.053 in) thick if made of steel or at least 1.9 mm (0.075 in) thick if made of metal other than steel.

10.2.3 The thickness of a crossbar may be reduced to 1.0 mm (0.040 in) for steel and 1.4 mm (0.055 in) for metal other than steel if reinforced by forming flanges along the edges.

10.2.4 The thickness of a crossbar may be less than 1.0 mm (0.040 in) for steel and 1.4 mm (0.055 in) for metal other than steel if the crossbar complies with the loading test of Clause 16.15.

10.2.5 A luminaire, including lamps, shall be provided with means of support independent of the outlet box and shall be marked and provided with installation instructions in accordance with Table 20.1.1, Items 1.21 and 1.33, if it is:

- (a) a ceiling surface type and weighs more than 22.7 kg (50 lb); or
- (b) a surface wall-mounted type and weighs more than 11.4 kg (25 lb).

10.2.5 (USA) In the United States, a luminaire, including lamps, shall be provided with means of support independent of the outlet box and shall be marked and provided with installation instructions in accordance with Table 20.1.1, Items 1.21 and 1.33, if it is:

- (a) a ceiling surface type and weighs more than 22.7 kg (50 lb); or
- (b) a surface wall-mounted type and weighs more than 22.7 kg (50 lb).

10.2.6 A two-piece polymeric electrical connector and support assembly for mounting a luminaire to an outlet box shall:

- (a) be provided with a means for connecting the neutral, ungrounded, and grounding conductors in accordance with Clause 6.14;
- (b) have no uninsulated live parts on the outlet box mounted piece that are accessible to incidental contact;
- (c) comply with the polymeric connector loading test specified in Clause 16.30;
- (d) employ polymeric materials that possess the following ratings:
  - (1) minimum V-1 flammability rating or compliance with the vertical burning flame test of Clause 16.26;
  - (2) minimum 90 °C mechanical temperature rating; and
  - (3) minimum dielectric voltage-withstand rating of 5000 V, a minimum hot wire ignition (HWI) rating of 7 s, and a minimum high current arc ignition (HAI) rating of 30 arcs; and
- (e) be provided with installation instructions in accordance with Table 20.1.1, Item 1.33, that
  - (1) specify proper installation, including the proper method for connecting the grounding means to the luminaire and a grounding lead in an outlet box; and
  - (2) include a statement that this product shall not be connected to a luminaire marked for supply wires rated more than 90 °C.

10.2.7 A luminaire that is supported by a lampholder screwshell shall not have:

- (a) a mass that exceeds 2.7 kg (6 lb); or
- (b) a dimension that exceeds 400 mm (15.75 in).

10.2.8 Any part supported by the external threads on the body of a lampholder shall comply with the loading test of Clause 16.15.

10.2.9 A luminaire intended to be mounted to an outlet box shall not be provided with a table, shelf, tray surface, basket, hook, eye, or other feature that allows the addition of weight.

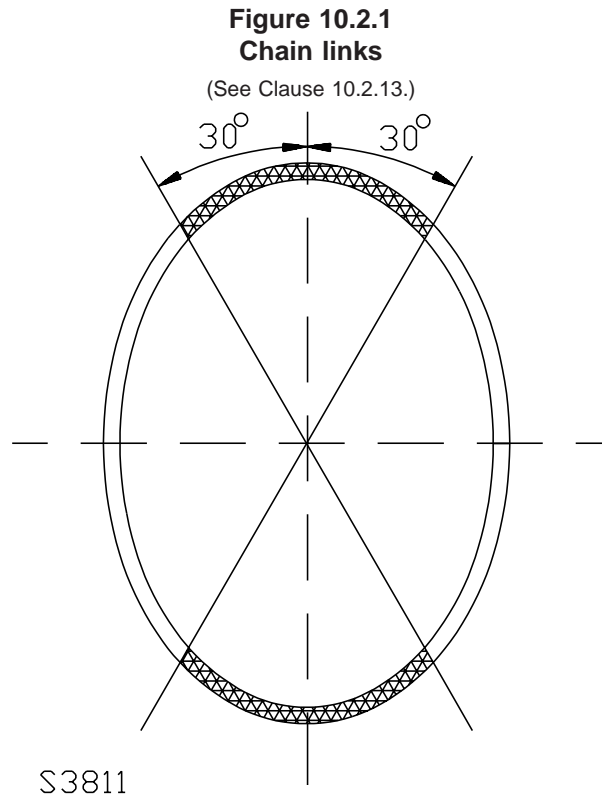
10.2.10 A luminaire provided with means to support it independently of the outlet box may be provided with a table, shelf, tray surface, basket, hook, eye, or other feature that allows the addition of weight.

10.2.11 A luminaire supported by chain or cable shall use stranded wire from the point that the wire exits the luminaire enclosure to the point where it connects to the branch circuit supply conductors. The weight of the luminaire shall be supported by the chain or cable, not the conductors.

10.2.12 A flexible cord providing the sole support of a luminaire or luminaire part shall not be subjected to kinks or sharp bends, and shall be at least:

- (a) a not-for-hard-usage jacketed type if supporting a mass of 2.3 kg (5 lb) or less; or
- (b) a hard-usage jacketed type if supporting a mass of 4.5 kg (10 lb) or less.

10.2.13 A joint in a circular chain link shall be welded. A joint in a chain link of another shape shall not be located within 30 degrees of the vertical, as shown in Figure 10.2.1, unless welded.



10.2.14 (MEX) In Mexico, pendant luminaires weighing more than 6.8 kg (15 lb) or luminaires intended to be supported by a suspended ceiling grid shall be manufactured so as to accommodate safety devices that will provide support independent of the threaded tube or ceiling grid that normally supports the luminaire.

### 10.3 Poles

10.3.1 A pole used for support of a luminaire shall serve as or contain a raceway that extends the entire length of the pole. It shall be constructed of the following materials:

- (a) metal;
- (b) metal-lined wood;
- (c) concrete; or
- (d) polymeric material that complies with Clause 5.7.

10.3.2 A circular metal pole shall be:

- (a) steel at least 1.01 mm (0.040 in) thick; or
- (b) aluminum alloy at least 1.27 mm (0.050 in) thick; and
- (c) if the pole supports a single luminaire weighing 4.5 kg (10 lb) or less mounted within 152 mm (6 in) of the center axis of the pole, the thickness of the metal may be 1/2 of the minimum thickness specified in Item (a) or (b), as applicable.

10.3.3 A metal pole that is other than circular in shape shall be:

- (a) steel at least 1.63 mm (0.064 in) thick; or
- (b) aluminum alloy at least 1.88 mm (0.074 in) thick.

10.3.4 A metal lining in a wood pole shall be

- (a) steel at least 0.66 mm (0.026 in) thick; or
- (b) other metal at least 0.81 mm (0.032 in) thick.

10.3.5 A pole shall be provided with the following:

- (a) a splice compartment;
- (b) a means for grounding the pole in accordance with Clause 6.14.2; and
- (c) a means for bonding a luminaire to the pole in accordance with Clause 6.14.3.

10.3.6 A pole 2.44 m (8 ft) or less in height shall not be required to be provided with the following:

- (a) a splice compartment, provided that
  - (1) the incoming supply wiring can be brought up through the pole without additional splices or pull points; and
  - (2) the interior of the pole and any splices are accessible by removal of the luminaire;or

(b) a grounding means, provided that the luminaire is grounded.

10.3.7 A splice compartment shall be located above ground level and shall be provided with a handhole that is:

(a) rectangular, not less than 50 mm (2 in) by 100 mm (4 in), with corners that may have a radius up to one-half of the width; or

(b) any other shape or size, provided a projected view of the finished opening encompasses the described area.

10.3.8 A pole having its own means for supply connection shall be constructed in such a way that the point of connection of conduit or cable shall be located at least 150 mm (6 in) from the lower end of the metal raceway.

10.3.9 A pole more than 30 m (100 ft) in length that is not provided with conductor support shall be marked in accordance with Table 20.1.1, Item 1.24.

10.3.10 A pole shall comply with the applicable requirements for wet locations specified in Clause 13.4.

10.3.11 A ferrous metal raceway shall comply with the corrosion protection requirements specified in Clause 13.4.2.

10.3.12 Aluminum intended for direct insertion into the ground or into concrete shall be provided with a protective coating.

10.3.13 (CAN) In Canada, poles over 4 meters shall also comply with the requirements of CSA C22.2 No. 206.

#### **10.4 Open holes and openings**

10.4.1 Open holes located 13 mm (0.5 in) or less from the surface on which the enclosure of a surface-mounted, outlet-box connected luminaire is intended to be mounted shall be considered to be one or more of the following:

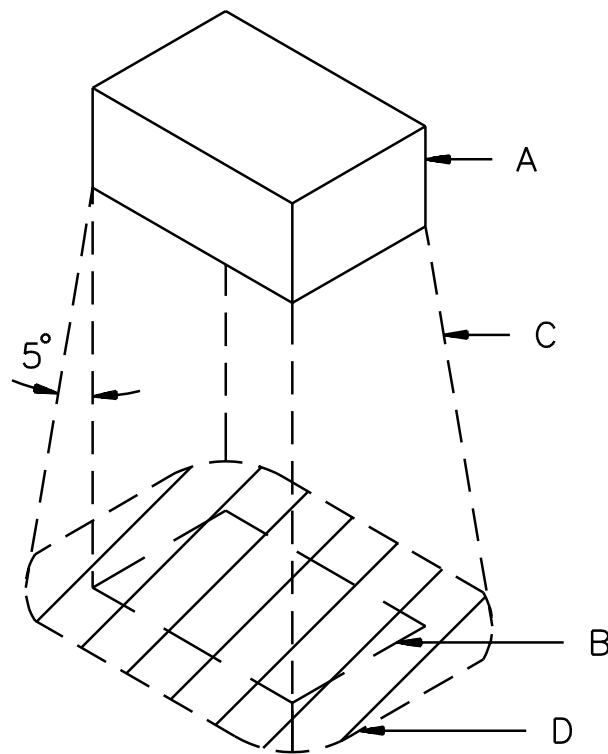
- (a) luminaire mounting holes;
- (b) component mounting holes;
- (c) pendant device mounting holes; or
- (d) access holes.

10.4.2 Open holes other than those specified in Clause 10.4.1 shall be considered to be general purpose open holes and shall comply with the requirements of Clause 10.4.3.

10.4.3 General purpose open holes, such as ventilating open holes, shall be located more than 13 mm (0.5 in) from the mounting surface of a luminaire and shall comply with the following:

- (a) the area of each open hole shall not exceed 10 cm<sup>2</sup> (1.5 in<sup>2</sup>).
- (b) the total area of holes shall be not more than 15 percent of the total area of the surface in which the hole or holes are located.
- (c) The open holes shall not be located in the mounting surface, in a canopy, or directly below electrical parts, as shown in Figure 10.4.1, that are required to be enclosed, unless the parts:
  - (1) are protected by a baffle in accordance with Clause 5.8;
  - (2) have demonstrated compliance with the applicable normal and abnormal test requirements; or
  - (3) are constructed so as not to present a risk of fire under any foreseeable conditions.

**Figure 10.4.1**  
**Location of baffle – directly below**  
(See Clauses 10.4.3, 10.4.4, and 10.4.6.)



Notes:

- A – Electrical component to be shielded by the baffle.
- B – Projection of the component outline on a horizontal plane.
- C – Inclined, 5 degree line, indicating minimum perimeter of the baffle.
- D – Minimum area of the baffle.

S3812A

10.4.4 Luminaire mounting holes may be any shape. A maximum of four open holes shall be permitted within the area directly below the outlet box opening in accordance with Figure 10.4.1. The maximum area of each hole shall be  $2.6 \text{ cm}^2$  ( $0.41 \text{ in}^2$ ). Two additional holes shall be permitted for each 610 mm (24 in) of luminaire length in excess of 1270 mm (50 in).

10.4.5 Component mounting holes may be provided in the back enclosure, facing the luminaire mounting surface, provided that they comply with the following:

- (a) The maximum diameter of any open holes is 7.9 mm (0.313 in).
- (b) The maximum area of each unclosed portion of a slot used to accommodate components mounted in place or of an unused slot intended for accommodation of alternate components is  $0.32 \text{ cm}^2$  ( $0.05 \text{ in}^2$ ).
- (c) The maximum total area of all unused open holes for alternate component mounting is  $5.16 \text{ cm}^2$  ( $0.80 \text{ in}^2$ ).

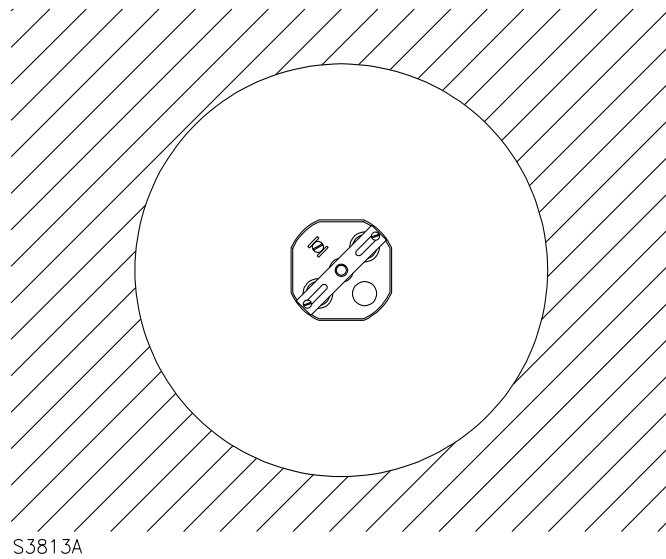
10.4.6 Component mounting holes that are not closed off shall not be located within the area directly below the outlet box opening shown in Figure 10.4.1, unless baffled in accordance with Clause 5.8.

10.4.7 A luminaire with a canopy that covers  $1160 \text{ cm}^2$  ( $180 \text{ in}^2$ ) or more of the mounting surface shall be provided with a back enclosure. The back enclosure shall comply with the enclosure requirements of Clause 5.3.1. An open hole in the back enclosure shall:

- (a) if circular, have a maximum area of  $1160 \text{ cm}^2$  ( $180 \text{ in}^2$ ) and have a maximum diameter of 380 mm (15 in), as shown in Figure 10.4.2; or
- (b) if not circular, have a maximum area of  $1160 \text{ cm}^2$  ( $180 \text{ in}^2$ ) and a maximum linear length, usually diagonal, of 660 mm (26 in), as shown in Figure 10.4.3.

**Figure 10.4.2**  
**Back enclosure – circular open hole**

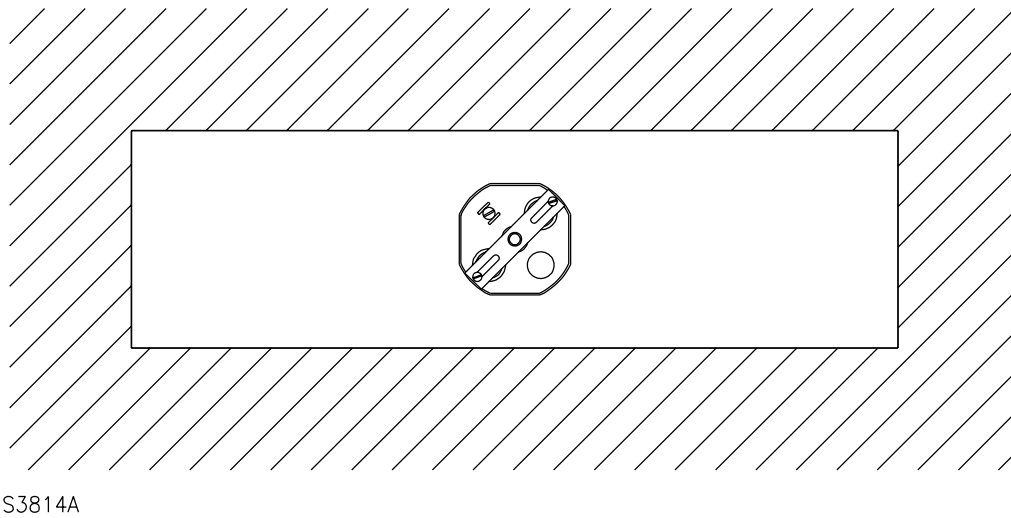
(See Clause 10.4.7.)



NOTE The circular open area is a maximum of 1160 cm<sup>2</sup> (180 in<sup>2</sup>) and a maximum of 380 mm (15 in) diameter.

**Figure 10.4.3**  
**Back enclosure – non-circular open hole**

(See Clause 10.4.7.)



NOTE The non-circular open area is a maximum of 1160 cm<sup>2</sup> (180 in<sup>2</sup>) and a maximum linear length, usually diagonal, of 660 mm (26 in).

10.4.8 A luminaire with a canopy that covers less than 1160 cm<sup>2</sup> (180 in<sup>2</sup>) of the mounting surface and has the dimensions specified in Clause 10.4.7, Item (a) or (b), is not required to be provided with a back enclosure.

10.4.9 An open hole in a luminaire enclosure need not comply with the requirements of Clause 10.4.5 or 10.4.7, provided that the open hole is closed off by a noncombustible mounting surface. The luminaire shall be marked for mounting on a noncombustible surface, in accordance with Table 20.1.1, Item 2.6. This marking is not required when the opening is covered by a glass fiber pad that complies with the glass fiber requirement of Clause 5.18.

10.4.10 An open hole or pair of holes may be provided for each stem or chain of a pendant device if each hole is closed by a suspension device. Knockouts may be provided in addition to, or in lieu of, the open hole or holes.

10.4.11 An opening for a pull switch in a sheet metal drop canopy secured by set screws shall be located within 90 mm (3.5 in) of the center of the canopy.

10.4.12 An opening for a pull switch in a sheet metal drop canopy secured by set screws that is reinforced by a minimum 3.2 mm (0.125 in) thick metal bar shall be located within 90 mm (3.5 in) of the means attaching the reinforcing bar to the canopy.

## **10.5 Accessibility of supply connections**

10.5.1 A luminaire shall allow for the inspection of branch circuit connections after installation. A luminaire weighing 4.54 kg (10 lb) or less, excluding diffusers, light-directing parts, and decorative parts, may be removed to provide access to branch circuit connections, without additional access openings.

10.5.2 An access opening or separate means of luminaire support shall be provided if branch circuit connections or internal wiring can be subjected to a force of more than 4.5 kg (10 lb) during installation or field inspection. Chain, cable, hinges, or equivalent means of luminaire support shall be capable of withstanding the loading test of Clause 16.15.

10.5.3 Access openings or openings through a supporting strap, cross-bar, or plate may be of any shape and shall be:

- (a) a single opening that allows passage of a rod having a diameter of 44.5 mm (1.75 in); or
- (b) two openings, each at least 10 cm<sup>2</sup> (1.5 in<sup>2</sup>) in area, that allow passage of a rod having a diameter of 16 mm (0.625 in).

## 10.6 Electrical construction

10.6.1 The cord of a cord-connected luminaire that is required to be grounded shall contain an equipment grounding conductor.

10.6.2 A conductor or flexible cord that is routed through the chain of a chain pendant luminaire shall have a minimum 0.80 mm (0.032 in) nominal insulation, and if a cord, it shall be at least Type SPT-1. A grounding conductor may be uninsulated.

10.6.3 A fluorescent or HID pendant luminaire designed for a chain, hook, or similar means of suspension may be provided with a flexible power cord.

10.6.4 Flexible cord provided with an attachment plug cap shall be at least of hard-usage type.

10.6.5 A flexible cord shall be provided with a strain-relief device that complies with the strain-relief test specified in Clause 16.21.1. The flexible cord on a chain or cable suspended luminaire shall not be required to be provided with strain relief.

10.6.6 A luminaire that can be adjusted, after installation, to change the angle of light shall be provided with one of the following:

- (a) a cord bushing and a length of flexible cord of hard-usage type or heavier for connection to branch circuit conductors; or
- (b) a junction box cord grip bushing without a length of flexible cord.

10.6.7 A luminaire shall be shipped with the cord mounted in place and connected.

10.6.7 (USA) In the United States, a luminaire may have a power supply cord that is not mounted in place and connected but shall be provided with installation instructions in accordance with Table 20.1.1, Item 1.33.

10.6.8 In a pendant luminaire, a bonding conductor may be terminated by hardware that is also used to secure a lampholder or lampholder bracket if that is the only available termination point and if that part of the lampholder is the only conductive part on the luminaire that is likely to become live.

10.6.9 (USA) In the United States, the temperature measured on the supply connections of a surface-mounted luminaire during the normal temperature test of Clause 14 shall:

- (a) not exceed 60 °C; or
- (b) not exceed 90 °C, and be marked for use with minimum 75 °C or 90 °C supply conductors, as appropriate, in accordance with Table 20.1.1, Item 1.1; or
- (c) not exceed 200 °C, and be marked:
  - (1) with a warning to prohibit use in dwellings, in accordance with Table 20.1.1, Item 2.5; and
  - (2) for use with minimum 105 °C, 125 °C, 150 °C, or 200 °C supply conductors, in accordance with Table 20.1.1, Item 1.1.

10.6.9 (CAN) In Canada, the temperature measured on the supply connections of a surface-mounted luminaire intended to be mounted on or over an outlet box during the normal temperature test of Clause 14 shall:

- (a) for wall-mounted luminaires, not exceed 75 °C;
- (b) for ceiling-mounted luminaires, not exceed 75 °C;
- (c) for ceiling-mounted luminaires, not exceed 90 °C, and be marked for use with minimum 90 °C supply conductors, in accordance with Table 20.1.1, Item 1.1; or
- (d) for ceiling or wall-mounted luminaires, not exceed 200 °C, and be marked
  - (1) with a warning to prohibit use in dwellings, in accordance with Table 20.1.1, Item 2.5; and
  - (2) for use with minimum 105 °C, 125 °C, 150 °C, or 200 °C supply conductors, in accordance with Table 20.1.1, Item 1.1.

10.6.10 (CAN) In Canada, the temperature measured on the supply connections of a surface-mounted luminaire with an integral outlet box during the normal temperature test of Clause 14 shall:

- (a) not exceed 75 °C; or
- (b) not exceed 90 °C, and the luminaire shall be marked for use with minimum 90 °C supply conductors, in accordance with Table 20.1.1, Item 1.1; or
- (c) not exceed 200 °C, and the luminaire shall be marked
  - (1) with a warning to prohibit use in dwellings, in accordance with Table 20.1.1, Item 2.5; and
  - (2) for use with minimum 105 °C, 125 °C, 150 °C, or 200 °C supply conductors in accordance with Table 20.1.1, Item 1.1.

## 10.7 Tests

10.7.1 A luminaire shall comply with the applicable normal temperature test of Clause 14.

10.7.2 A luminaire that appears to be suitable for either ceiling mounting or wall mounting shall be tested as one of the following:

(a) a ceiling-mounted luminaire; or

(b) a wall-mounted luminaire, and it shall be marked for wall mounting only, in accordance with Table 20.1.1, Item 2.10.

10.7.3 A luminaire that is intended for under-cabinet mounting shall comply with the temperature test of Clause 14.4.

10.7.3 (CAN) In Canada, under-cabinet luminaires are not within the scope of this Standard.

10.7.4 (MEX) In Mexico, pole- or arm-mounted luminaires intended for exterior public lighting shall comply with the vibration test of Clause 16.37 (MEX).

## 10.8 Markings

10.8.1 A luminaire that requires branch circuit conductors rated greater than 60 °C and that may be installed in a dwelling shall include a caution and an installation warning marking on the luminaire and the carton, in accordance with Table 20.1.1, Items 3.17 and 1.32. Item 1.32 may be omitted if the carton is marked with Items 3.17 and 1.31 of Table 20.1.1.

10.8.1 (CAN) In Canada, the caution and installation markings of Table 20.1.1, Items 3.17 and 1.32, shall not be required on the carton.

10.8.2 (USA) In the United States, a luminaire intended for under-cabinet mounting shall be marked in accordance with Table 20.1.1, Item 2.12.

10.8.3 A ceiling-mounted luminaire tested on an uninsulated ceiling shall be marked in accordance with Table 20.1.1, Item 2.6.

10.8.4 A luminaire that has a flexible power cord and attachment plug and that is not provided with a hook, loop, or chain shall be marked for chain and hook suspension only, in accordance with Table 20.1.1, Item 1.22.

## 11 Recessed luminaires – supplementary requirements

### 11.1 General

11.1.1 The requirements in Clause 11 are supplementary to other applicable requirements in this Standard.

11.1.1 (MEX) In Mexico, the requirements in Clause 11 are not required.

11.1.2 Polymeric material used to form an enclosure or a housing or to provide structural support shall comply with the requirements of Clauses 5.7.1, 5.7.2, and 11.7.2.

11.1.3 A recessed luminaire intended for installation in a suspended ceiling and weighing more than 22.7 kg (50 lb) shall have provision for support independent of the ceiling grid.

11.1.4 A luminaire provided with integral suspended ceiling clips shall comply with the security of clips test of Clause 16.18 and shall be provided with installation instructions that specify the grid type, in accordance with Table 20.1.1, Item 1.33.

## 11.2 Enclosures

11.2.1 The surfaces of an enclosure described in Clause 5.3.2 that are not visible from the room side shall have no open holes, except as specified in Clauses 11.3.8 and 11.4.3.

11.2.2 Open holes in the surface of an enclosure of live parts that are visible from the room side shall comply with the requirements of Clause 10.4.

## 11.3 Junction boxes

11.3.1 A junction box that complies with the component requirements of Clause 4.1 and is attached to a luminaire may have openings that do not comply with Clauses 11.2.1 and 11.2.2.

11.3.2 The wiring compartment (junction box) where the branch circuit connections to the luminaire are made shall be integral to the luminaire or securely fastened to its enclosure or frame. A wiring compartment attached by flexible conduit shall have additional means of securement.

11.3.3 A luminaire provided with a through-wire junction box shall be marked with the number and size of the branch circuit conductors in accordance with Table 20.1.1, Item 1.40, and shall:

- (a) be provided with hanger bars that attach either directly to the junction box or within 51 mm (2 in) of the junction box on the bracket that secures the junction box to the luminaire; or
- (b) comply with the junction box rigidity test of Clause 16.31; or
- (c) be marked for use with cable in accordance with Table 20.1.1, Item 1.37.

11.3.4 A luminaire marked in accordance with Clause 11.3.3 shall be considered in compliance with Clause 11.8.1.1. No additional marking is required.

11.3.5 A polymeric junction box shall comply with the requirements of Clause 4.1.

11.3.6 The minimum inside volume of the junction box shall comply with Clause 6.16.

11.3.7 The thickness of a junction box, excluding covers, shall be a minimum of 1.25 mm (0.050 in) if sheet steel, 2.3 mm (0.09 in) if nonferrous sheet metal, or 3.2 mm (0.125 in) if cast metal, with the following exceptions:

- (a) the minimum thickness at or within 6.4 mm (0.25 in) of any right-angle bend in a drawn sheet steel box may be 0.9 mm (0.035 in).
- (b) the average thickness of the sides and ends of a drawn steel box may be 1.24 mm (0.049 in), based on three measurements made on the side and end of the box, but a minimum of 9.5 mm (0.375 in) from a right-angle bend. The three measurements shall be made in a line perpendicular to the front of the box at the following points: a point 6.4 mm (0.25 in) from the front, a point 6.4 mm (0.25 in) from the right-angle bend at the back, and a point equidistant between the two.
- (c) the wall of a malleable iron box or a die-cast or permanent-mold-cast aluminum, brass, or bronze box shall be in accordance with Table 5.5.2.
- (d) a wall thickness of minimum 2.4 mm (0.094 in) shall be accepted for clearance of a cover screw in the area directly beneath the cover mounting lug if that area is no larger than 32.36 mm<sup>2</sup> (0.050 in<sup>2</sup>) and has no straight-line dimension more than 12.7 mm (0.5 in).
- (e) if a luminaire is marked for use with cable only as specified in Clause 11.3.3, the junction box may be in accordance with the thickness requirement for openings for conduit connection specified in Table 5.5.1.
- (f) if the luminaire complies with the junction box rigidity test of Clause 16.31, the junction box shall not be less than the thickness requirement for openings for conduit connection specified in Table 5.5.1.

11.3.8 An open hole in a box, such as a mounting-screw hole, shall have no dimension larger than 6.7 mm (0.265 in), except that a pryout hole or slot may be provided in a knockout for 1 in or smaller trade size conduit, provided that the area of the hole or slot is no more than 26 mm<sup>2</sup> (0.040 in<sup>2</sup>).

11.3.9 Unless it has been threaded or provided with a threaded connector, an open hole in a junction box intended for the entrance of conduit, armoured cable, or other wiring system shall be effectively closed.

11.3.10 The thickness of a sheet steel plug or plate used to close an open hole in a metal junction box shall be as specified in Table 11.3.1.

11.3.11 The thickness of a junction box cover shall be no less than:

- (a) for sheet metal, the thickness requirements for enclosures specified in Table 5.5.1; or
- (b) for cast metal, the thickness requirements of Table 5.5.2.

**Table 11.3.1**  
**Closure plug or plate thickness**

(See Clause 11.3.10.)

Diameter of open hole in metal outlet box,		Minimum thickness of a sheet steel plug or plate,		Minimum thickness of a sheet aluminum plug or plate,	
mm	(in)	mm	(in)	mm	(in)
Less than or equal to 32	(1.26)	0.7	(0.028)	2	(0.079)
More than 32	(1.26)	1.3	(0.051)	2	(0.079)

11.3.12 Metal junction boxes having an integral strain-relief mechanism for cable shall comply with the cable pull test of Clause 16.40 or with the requirements of Clause 4.1.

#### 11.4 Recessed housing

11.4.1 A recessed housing shall close off the opening in the surface in which it is mounted.

11.4.2 A housing shall have a minimum thickness of 0.66 mm (0.026 in) if ferrous metal or 0.71 mm (0.028 in) if nonferrous metal.

11.4.3 Where a luminaire recessed housing also serves as an enclosure, a top surface that is less than 30 degrees from the horizontal and any outer wall that contains any of the parts specified in Clause 5.3.2 shall have:

- (a) a maximum of two pryout slots, each having a maximum area of 26 mm<sup>2</sup> (0.04 in<sup>2</sup>); and
- (b) ballast mounting slots, each having a maximum unused area of 26 mm<sup>2</sup> (0.04 in<sup>2</sup>).

11.4.4 A recessed housing of a Type Non-IC luminaire that does not serve as an enclosure may have open holes in the shape of a slot or louvre that shall be a maximum 9.5 mm (0.375 in) wide and 10 cm<sup>2</sup> (1.5 in<sup>2</sup>) in area. Any other open hole shall not allow passage of a rod having a diameter of 25 mm (1 in) and not exceed 10 cm<sup>2</sup> (1.5 in<sup>2</sup>) in area. The total area of all open holes shall be maximum 15 percent of the area of the opening in the mounting surface closed off by the recessed housing.

11.4.5 A recessed housing of a Type IC luminaire that does not serve as an enclosure may have open holes in the shape of a slot or louvre that shall be a maximum 4.8 mm (0.188 in) wide and 10 cm<sup>2</sup> (1.5 in<sup>2</sup>) in area. Any other open hole shall not allow passage of a rod having a diameter of 6.4 mm (0.25 in) and shall not exceed 10 cm<sup>2</sup> (1.5 in<sup>2</sup>) in area. The total area of all open holes shall be a maximum of 15 percent of the area of the opening in the mounting surface closed off by the recessed housing.

11.4.6 A luminaire intended for installation in poured concrete shall be constructed to prevent the ingress of wet concrete into the areas provided for supply connection in a quantity sufficient to interfere with normal operation, shall comply with Clause 14.9, and shall be marked for installation in poured concrete in accordance with Table 20.1.1, Item 2.21.

11.4.7 A luminaire with openings in the housing that exceed those specified in Clause 11.4.3, 11.4.4, or 11.4.5 shall be marked for use in non-fire-rated installations only, in accordance with Table 20.1.1, Item 1.26.

## 11.5 Thermal protectors

### 11.5.1 General

11.5.1.1 A recessed luminaire shall be provided with a thermal protector unless the luminaire is:

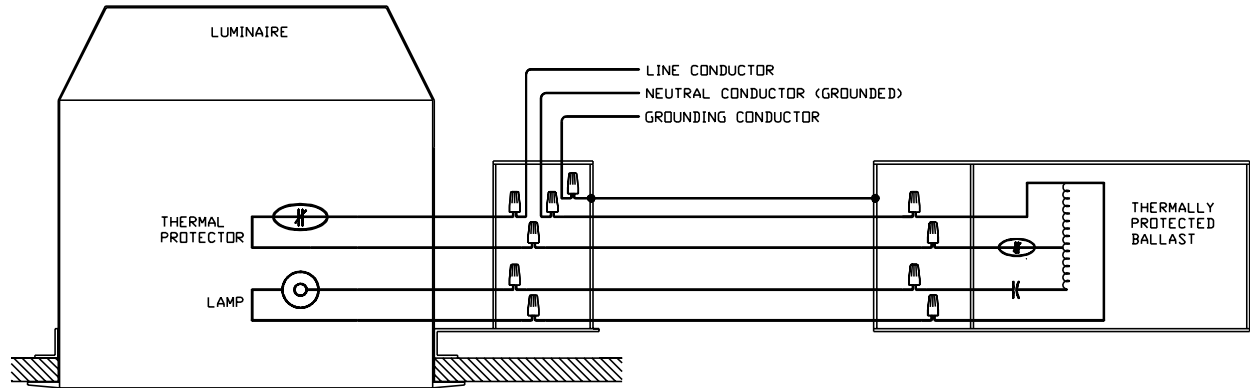
- (a) intended to be installed in concrete only, as specified in Clause 11.4.6;
- (b) inherently protected, complies with the temperature test of Clause 14.8, and is marked in accordance with Table 20.1.1, Item 2.24;
- (c) intended to be installed in the ground only and is marked in accordance with Table 20.1.1, Item 2.27;
- (d) intended to be installed in an outdoor canopy or marquee where it is not intended to be covered with thermal insulation, and is marked in accordance with Table 20.1.1, Item 2.26;
- (e) fluorescent, when the ballast is required to have a thermal protector in accordance with Clause 8; or
- (f) HID, Type IC, and marked in accordance with Table 20.1.1, Item 2.23.

11.5.1.2 A thermal protector shall comply with the requirements of Clause 4.1.

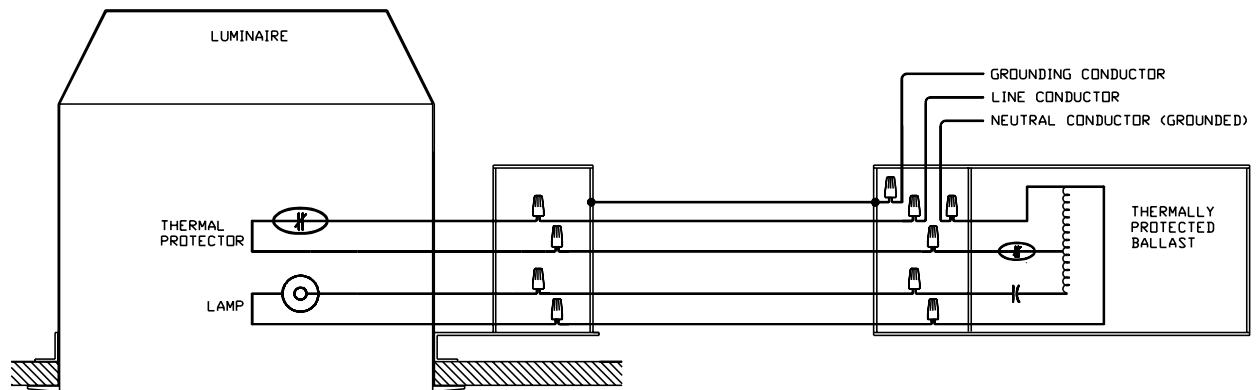
11.5.1.3 A thermal protector may be of the self-heating thermal protector (SHTP) type. If a self-heating thermal connector is connected to a grounded supply, it shall be connected in the ungrounded supply conductor. Figures 11.5.1.1 and 11.5.1.2 provide HID luminaire examples.

**Figure 11.5.1.1**  
**Wiring diagrams for an HID luminaire thermal protector between a remote ballast and a recessed luminaire**

(See Clause 11.5.1.3.)



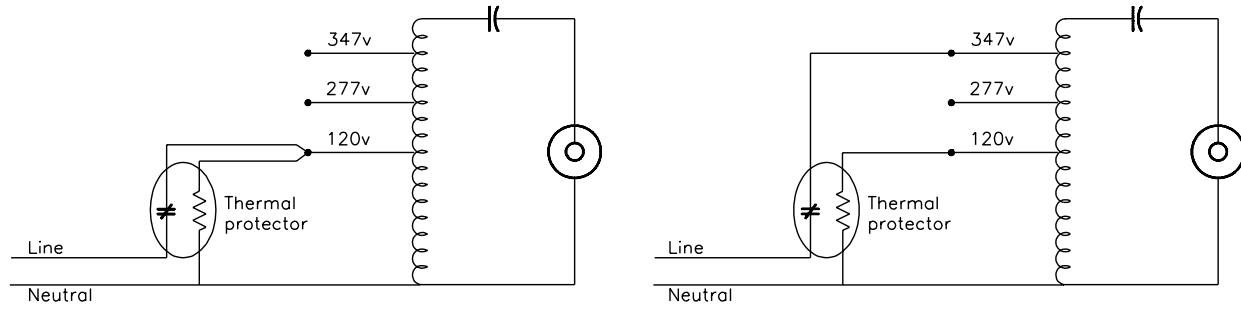
BRANCH CIRCUIT CONNECTED TO THE LUMINAIRE JUNCTION BOX



BRANCH CIRCUIT CONNECTED TO THE BALLAST JUNCTION BOX

**Figure 11.5.1.2**  
**Wiring diagrams for an HID luminaire with a multi-tap autotransformer ballast and thermal protector with a 120 V integral heater**

(See Clause 11.5.1.3.)



S3816A

11.5.1.4 The thermal protector in a luminaire with a ballast or transformer shall be rated for inductive loads and the voltage and current involved.

11.5.2 Thermal protectors for HID luminaires

11.5.2.1 An HID luminaire with a thermal protector that is intended to be connected in the luminaire circuit in the field shall be pre-wired to a plug or receptacle so that the protector cannot be unintentionally bypassed.

### 11.5.3 Thermal protectors for incandescent luminaires

11.5.3.1 A thermal protector in a luminaire with medium-base lampholders that can accommodate lamps of higher wattage than that marked on the lamp replacement shall have a minimum rating of 300 W Tungsten multiplied by the number of medium-base lampholders.

11.5.3.2 The thermal protector in a luminaire with other than medium-base lampholders that can accommodate lamps of higher wattage than that marked on the lamp replacement shall have a minimum tungsten lamp wattage rating equal to twice the maximum wattage specified in the lamp replacement marking multiplied by the number of lampholders that it controls.

## 11.6 Electrical construction

### 11.6.1 Inspection of supply connections

11.6.1.1 The branch circuit connections shall be accessible for visual inspection from the room side of the luminaire, unless:

- (a) the luminaire is marked to restrict its use to installations where there is ready access to the ceiling side of the luminaire, in accordance with Table 20.1.1, Item 2.7; or
- (b) access to branch circuit connections is provided in accordance with Clause 11.6.1.2.

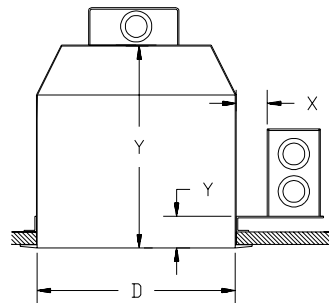
11.6.1.2 The branch circuit connections are considered accessible from the room side of the luminaire if:

- (a) the center of the wiring compartment cover is visible through the access opening; and
- (b) all parts that are required to be removed to gain access are easily removed and replaced from the room side of the luminaire; and
- (c) the luminaire construction is such that
  - (1) the diameter of the access opening is not less than 150 mm (6 in); or
  - (2) it complies with the splice inspection test of Clause 16.32; or
  - (3) the diameter of the access opening is less than 150 mm (6 in), as determined by the following equation, where X and Y are in accordance in Figure 11.6.1.1:

$$D \geq 75 + X + Y$$

**Figure 11.6.1.1**  
**Access to supply connections**

(See Clause 11.6.1.2.)



S3817

Legend:

D = smallest diameter of the access opening, mm

X = distance from the edge of the access opening to the plane of the nearest surface of a wiring compartment, mm

Y = distance from the plane of the access opening to the plane of the nearest surface of a wiring compartment that is parallel to the plane of the access opening, mm

11.6.1.3 The branch circuit connections of a luminaire intended for use in poured concrete shall be accessible from the relamping side of the luminaire.

## 11.6.2 Tap conductors

11.6.2.1 A tap conductor supplied with a luminaire shall:

- (a) be enclosed in a raceway extending at least 450 mm (18 in) but not more than 2 m (6.5 ft) from the luminaire;
- (b) extend at least 150 mm (6 in) from the raceway; and
- (c) be at least 18 AWG if enclosed in a factory-installed raceway, or at least 14 AWG when supplied with a raceway and connectors for field installation.

11.6.2.1 (USA) In the United States, tap conductors furnished with the luminaire shall be building or fixture wire with an insulation thickness as specified in Table 11.6.2.1 (USA). The tap conductors shall extend at least 610 mm (24 in) but not more than 2 m (6.5 ft) beyond the recessed enclosure.

**Table 11.6.2.1 (USA)**  
**Wire insulation thickness and maximum number of conductors in 3/8 in flexible metal conduit**

(See Clauses 11.6.2.1 (USA) and 11.6.2.2 (USA).)

Size,		Maximum 0.8 mm (0.03 in) insulation with outer jacket <sup>a</sup>		0.5 – 0.8 mm (0.02 – 0.03 in) insulation with outer jacket <sup>b</sup>		0.4 mm (0.015 in) insulation with outer jacket <sup>c</sup>		0.14 – 0.4 mm (0.006 – 0.015 in) insulation without outer jacket <sup>d</sup>	
AWG	(mm <sup>2</sup> )	Inside <sup>e</sup>	Outside <sup>f</sup>	Inside <sup>e</sup>	Outside <sup>f</sup>	Inside <sup>e</sup>	Outside <sup>f</sup>	Inside <sup>e</sup>	Outside <sup>f</sup>
18	0.82	2	3	3	5	5	8	5	8
16	1.3	1	2	3	4	4	6	4	6
14	2.1	1	2	2	3	3	4	3	4
12	3.3	–	–	1	2	2	3	2	3
10	5.3	–	–	1	1	1	1	1	2

NOTE In addition, installation of one uninsulated grounding conductor of the same AWG size is optional.

<sup>a</sup> Examples: RH, RHH, FFH-2, RFH-2, SF-2, SFF-2.  
<sup>b</sup> Examples: T, TW, XHHW, ZW, RUH, RUW, PFA, PFAH, TFE, TF, TFF, PF, PGF, PFF, PGFF.  
<sup>c</sup> Examples: THHN, THWN, Z, RFH-1, FFH-1, TFN, TFFN, SF-1.  
<sup>d</sup> Examples: KF-1, KF-2, KFF-1, KFF-2, SFF-1, HF, HFF, ZF, ZFF.  
<sup>e</sup> Fitting is able to be located inside conduit.  
<sup>f</sup> Fitting shall be outside conduit.

11.6.2.2 (USA) In the United States, a luminaire furnished with tap conductors without flexible metal conduit shall be furnished with a connection fitting for either:

- (a) 1/2 in or larger trade size conduit; or
- (b) 3/8 in trade size conduit, provided the maximum number of conductors and the type of fitting are in accordance with the wire size and type shown in Table 11.6.2.1 (USA).

### 11.6.3 Rough-in and finishing sections

11.6.3.1 If electrical connections are required between the rough-in and finishing sections, they shall be completed by plugging an attachment plug provided as part of the finishing section into a receptacle on the rough-in section.

## 11.7 Tests

### 11.7.1 Temperature

11.7.1.1 A luminaire shall comply with the normal and abnormal temperature tests in accordance with Table 11.7.1.1.

**Table 11.7.1.1**  
**Recessed luminaire temperature tests**

(See Clauses 11.7.1.1 and 11.7.1.6.)

Type	Fluorescent		Incandescent				HID		
	Non-IC	IC	Non-IC	Non-IC marked spacings	IC	IC inherently protected	Non-IC	Non-IC marked spacings	IC
<b>Normal temperature tests</b>									
<b>Test Clause</b>	14.5	14.7	14.5	14.6	14.7	14.8	14.5	14.6	14.7
<b>Abnormal temperature tests</b>									
<b>Insulation test</b>			15.2	15.3.1			15.2	15.3.1	
<b>Reduced spacings test</b>				15.3.2				15.3.2	
<b>Overlamping test</b>					15.4.2				
<b>Mislamping test</b>					15.4.3				

11.7.1.2 A Type Non-IC luminaire with standard spacings shall comply with the normal temperature test of Clause 14.5 and the abnormal temperature test of Clause 15.2. A fluorescent luminaire that incorporates thermal protection within an integral ballast is not required to be subjected to the abnormal temperature test.

11.7.1.3 A Type Non-IC luminaire with marked spacings shall comply with the normal temperature test of Clause 14.6 and the abnormal temperature test of Clause 15.3.

11.7.1.4 A Type IC luminaire with a thermal protector shall comply with the normal temperature test of Clause 14.7 and the abnormal temperature test of Clause 15.4.

11.7.1.5 A Type IC luminaire that is inherently protected shall comply with the normal temperature test of Clause 14.8.

11.7.1.6 A convertible recessed luminaire shall comply with the requirements for both Type Non-IC and Type IC luminaires specified in Table 11.7.1.1.

11.7.1.7 Each combination of trim/finishing section and housing/rough-in section shall comply with the performance requirements of Clause 11.7.1.

11.7.1.8 A trim/finishing section shall be used with the housing/rough-in section of the same manufacturer.

11.7.1.8 (USA) In the United States, a trim/finishing section made by a manufacturer other than the recessed housing/rough-in section manufacturer shall be tested with all lamp wattages and types identified for use with the trim/finishing section it is intended to replace and shall be marked in accordance with Table 20.1.1, Item 1.10.

11.7.1.9 A luminaire intended to be installed in concrete only shall comply with Clause 14.9 and shall be marked in accordance with Table 20.1.1, Item 2.20.

11.7.1.10 A ground-mounted recessed luminaire shall comply with the test of:

- (a) Clause 14.5; or
- (b) Clause 14.9 and shall comply with one of the following requirements:
  - (1) it shall have normal operating temperatures on the mounting surfaces and recessed housing of 90 °C or less and be marked for ground mounting only, in accordance with Table 20.1.1, Item 2.27; or
  - (2) it shall be marked for noncombustible surfaces only, in accordance with Table 20.1.1, Item 2.6.

11.7.1.11 A canopy-type luminaire shall be

- (a) tested in accordance with Clause 14.5 and marked as a canopy-type luminaire – not thermally protected, in accordance with Table 20.1.1, Item 2.26; or
- (b) tested in accordance with Clause 14.6, marked as a canopy-type luminaire – not thermally protected, in accordance with Table 20.1.1, Item 2.26, and marked to indicate the minimum acceptable spacings in accordance with Table 20.1.1, Item 1.19.

11.7.1.12 A canopy-type luminaire that is marked for uncovered ceiling only, in accordance with Table 20.1.1, Item 2.25, shall be tested in accordance with Clause 14.5 for standard spacings or in accordance with Clause 14.6 for marked spacings, with no top on the test box.

11.7.1.13 A recessed luminaire provided with means to vary the depth of a lampholder within a lamp compartment or recessed housing shall be tested without the lampholder mounting bracket stop in place if the stop does not comply with the lampholder mounting stop test of Clause 16.35.

## 11.7.2 Polymeric tests

11.7.2.1 Polymeric parts that serve as enclosures or housings required by this Standard shall comply with the tests in Clauses 11.7.2.2 to 11.7.2.4.

11.7.2.2 Using the test apparatus of Clause 19.21, an impact of 7 J (5 ft-lb) shall be applied to the polymeric part. The test shall be conducted

- (a) at an ambient temperature of 25 °C; and
- (b) immediately after conditioning for 3 h in a freezer operating at 0 °C.

11.7.2.3 For a polymeric part that is intended for wet locations, an impact of 7 J (5 ft-lb) shall be applied, using the test apparatus specified in Clause 19.21. The test shall be conducted immediately after cold conditioning for 3 h at -35 °C for assemblies, such as outer housings, exposed to the room side or ceiling side of the installation.

11.7.2.4 A polymeric housing supporting a screw-shell-type lampholder shall be subjected to the lampholder mounting torque test of Clause 16.33 and the pull test of Clause 16.34.

## 11.8 Markings

### 11.8.1 General

11.8.1.1 The temperature of the branch circuit connections of a luminaire intended for use in a dwelling unit, when subjected to the normal temperature test of Clause 14, shall not exceed 90 °C, and the luminaire shall be marked in accordance with Clause 6.15.1.5.

11.8.1.2 The temperature of the branch circuit connections of a luminaire intended for use in other than a dwelling unit, when subjected to the normal temperature test of Clause 14, shall

- (a) not exceed 200 °C;
- (b) be marked for use with the appropriate temperature for branch circuit conductors, in accordance with Table 20.1.1, Item 1.1; and
- (c) be marked not for use in dwellings, in accordance with Table 20.1.1, Item 2.5.

11.8.1.3 If the temperature on any part of the luminaire mounting surface or recessed housing exceeds the limit for combustible building parts as shown in Table 14.1.2, Item 17, during the normal temperature test of Clause 14, the luminaire shall be marked for mounting on noncombustible material, in accordance with Table 20.1.1, Item 2.17.

11.8.1.4 A recessed luminaire that requires access from above the ceiling or from behind the wall to inspect splices shall be marked in accordance with Table 20.1.1, Item 2.7 or 2.8.

11.8.1.5 A rough-in section shall be marked to indicate the appropriate finishing section to be used, in accordance with Table 20.1.1, Item 1.34.

11.8.1.6 A trim/finishing section shall be marked with the manufacturer's identification and catalogue number, in accordance with Table 20.1.1, Items 4.1 and 4.2.

11.8.1.7 A luminaire intended to be shipped separately from the trim shall be marked for trim identification, in accordance with Table 20.1.1, Item 1.9.

11.8.1.8 A recessed luminaire with a thermal protector that is acceptable for connection to a branch circuit supply rated in excess of 20 A may be marked 30 A or 40 A, to indicate the maximum branch circuit rating, in accordance with Table 20.1.1, Item 1.2.

11.8.1.9 An incandescent recessed luminaire employing a mogul base lampholder and a thermal protective device with a 20 A branch circuit rating shall be marked for connection to a branch circuit of 20 A max, in accordance with Table 20.1.1, Item 1.2.

11.8.1.10 A Type Non-IC incandescent or HID luminaire shall be marked with a caution to keep it away from insulation and with the statement that a blinking light can indicate overheating, in accordance with Table 20.1.1, Items 1.13 and 3.11.

11.8.1.11 A Type IC luminaire shall be marked with the luminaire type and with the statement that a blinking light can indicate overheating, in accordance with Table 20.1.1, Items 2.23 and 3.11.

11.8.1.12 A Type IC luminaire shall be marked to indicate the minimum vapor barrier temperature, in accordance with Table 20.1.1, Item 1.14.

11.8.1.12 (USA) In the United States, the minimum vapor barrier temperature marking of Table 20.1.1, Item 1.14, shall not be required.

11.8.1.13 An inherently protected Type IC luminaire shall be marked with the luminaire type and with the statement that it is inherently protected, in accordance with Table 20.1.1, Items 2.23 and 2.24.

11.8.1.14 A ground-mounted recessed luminaire tested in sand during the normal temperature test of Clause 14.9 shall be marked ground-mounted recessed installation only or for installation in concrete only, in accordance with Table 20.1.1, Item 2.27 or 2.20.

## 11.8.2 Lamp replacement

11.8.2.1 A recessed luminaire shall be marked with a caution, the maximum lamp wattage, and the type, in accordance with Table 20.1.1, Items 3.17 and 3.1.

11.8.2.1 (CAN) In Canada, the caution marking of Table 20.1.1, Item 3.17, shall not be required.

11.8.2.2 Where a luminaire construction consists of a rough-in or housing section and a trim or finishing section, the relamping information shall be visible during relamping with all components installed in place.

11.8.2.3 The lamp replacement marking may be concealed behind a trim or finishing section that must be removed during relamping.

11.8.2.4 The lamp replacement marking may be concealed behind a trim or finishing section that is not required to be removed during relamping if the visible portion of the trim or finishing section is marked to indicate that the relamping marking is located on the concealed side, in accordance with Table 20.1.1, Item 3.15.

11.8.2.5 A luminaire construction that requires a different lamp wattage or type for an alternate trim or finishing section shall be marked with a caution, the maximum lamp wattage, and the type in accordance with Table 20.1.1, Items 3.17 and 3.1 (see examples in Tables 20.1.4, 20.1.5, and 20.1.6).

11.8.2.5 (CAN) In Canada, the caution marking of Table 20.1.1, Item 3.17, shall not be required.

### 11.8.3 Marked spacings

11.8.3.1 A Type Non-IC luminaire with marked spacings, as shown in Figures 19.14.1.1 and 19.14.1.2, shall be marked in accordance with Table 20.1.1, Item 1.19, to indicate the minimum spacings required to comply with the temperature test of Clause 14.6. The spacings shall be determined as follows:

- (a) the minimum permissible center-to-center spacing of adjacent luminaires shall be determined by measuring the length and width of the luminaire, and adding 300 mm (12 in) to the larger dimension. The result shall be evenly divisible by 300 mm (12 in) or be rounded up to the next larger number evenly divisible by 300 mm (12 in), but in no case shall be less than 600 mm (24 in). The markings shall be 600, 900, 1200, 1500, or 1800 mm (24, 36, 48, 60, or 72 in) or larger, in increments of 300 mm (12 in).
- (b) from the top of luminaire to the overhead building member the spacing shall be as follows: 13, 75, 150, 200, 250, 300, 380, 460, 600, 760, 900, 1050, or 1200 mm (0.5, 3, 6, 8, 10, 12, 15, 18, 24, 30, 36, 42, or 48 in) or larger, in increments of 150 mm (6 in).
- (c) the luminaire center-to-side building member spacing shall be 1/2 the value specified in Item (a).

### 11.8.4 Convertible recessed luminaires – Type Non-IC to Type IC

11.8.4.1 A convertible luminaire shall comply with the applicable requirements for both Type Non-IC and Type IC recessed luminaires. In addition, the following requirements shall apply:

- (a) a rough-in section shall be marked to identify it as a convertible luminaire rough-in section, in accordance with Table 20.1.1, Item 1.36.
- (b) a rough-in section for a convertible recessed luminaire shall be marked with correlation markings that identify the trim/finishing section combinations that result in a Non-Type IC luminaire and those that result in a Type IC luminaire. The markings shall be located inside the housing or rough-in section and shall be in accordance with Table 20.1.1, Item 1.38.
- (c) a trim/finishing section for a convertible recessed luminaire shall be marked with the manufacturer's identification and catalogue designation, in accordance with Table 20.1.1, Items 4.1 and 4.2.
- (d) a finishing section for a convertible recessed luminaire shall have a correlation marking, in accordance with Table 20.1.1, Item 1.35.
- (e) a label shall be located on the housing or rough-in section instructing the installer to keep insulation 76 mm (3 in) away, in accordance with Table 20.1.1, Item 1.13.
- (f) the label in Item (e) shall be easily removable. The installation instructions shall specify that this label shall be removed when installed as a Type IC luminaire, in accordance with Table 20.1.1, Item 1.33.
- (g) the Type IC marking in Table 20.1.1, Item 2.23, shall not be provided.
- (h) installation instructions shall be provided with each housing/rough-in section and shall include the following, in accordance with Table 20.1.1, Item 1.33:

- (1) a statement defining each type of installation. For example, “Type IC installation – luminaire housing/rough-in section is in direct contact with thermal insulation” or “Type Non-IC installation – thermal insulation does not cover top of luminaire housing/rough-in section and is spaced 76 mm (3 in) from all sides”;
- (2) for IC installations, instructions to remove the peel-off label on top of housing section that advises not to install insulation within 76 mm (3 in) of any part of the luminaire in accordance with Table 20.1.1, Item 1.13; and
- (3) instructions directing the installer on the proper choice of finishing section/trim and lamp for the application.

#### 11.8.5 Luminaires with polymeric parts

11.8.5.1 Installation instructions for a luminaire provided with a polymeric junction box or wiring compartment shall specify the type of wiring method to be employed, in accordance with Table 20.1.1, Item 1.33.

11.8.5.2 A luminaire that is provided with a polymeric recessed housing shall be marked not for use in fire-rated installations and for use in one- and two-family dwellings only or not for use in environmental air spaces, in accordance with Table 20.1.1, Items 1.26 and 1.39.

### 12 Miscellaneous luminaires – supplementary requirements

#### 12.1 General

12.1.1 The requirements in Clause 12 are supplementary to other applicable requirements in this Standard.

#### 12.2 Air-handling luminaires

##### 12.2.1 General

12.2.1.1 The requirements in Clause 12.2 apply to both recessed and surface-mounted luminaires for use with heating, ventilating, and air-conditioning systems in accordance with NFPA 90A and the *National Building Code of Canada*.

12.2.1.2 The requirements in Clause 12.2 also cover plastic light diffusers or lenses intended for use with an air-handling luminaire.

## 12.2.2 Mechanical construction

12.2.2.1 The air path shall not be through the electrical enclosure.

12.2.2.2 Lamps and lampholders may be located in an air path.

12.2.2.3 A nonmetallic material, adhesive, or coating used for a part, other than a lamp, lampholder, or light diffuser, that is located in the air path or plenum shall comply with the flame test of Clause 12.2.3.1.

12.2.2.3 (USA) In the United States, a nonmetallic material, adhesive, or coating used for a part, other than a lamp, lampholder, or light diffuser, that is located in the air path or plenum shall:

- (a) comply with the flame test of Clause 12.2.3.1; or
- (b) have a maximum 25 flamespread rating and a smoke developed rating of maximum 50 or "light" or "negligible". The ratings shall be obtained as described in UL 723.

12.2.2.4 A frame or support for a plastic diffuser shall:

- (a) provide a complete metal U-shaped channel around the perimeter of the diffuser;
- (b) overlap the diffuser a maximum of 19.1 mm (0.75 in) at either (short) end and a maximum of 12.7 mm (0.5 in) on either (long) side; and
- (c) provide a visible clearance between the diffuser and each section of the channel; or
- (d) be investigated and found to be equivalent.

12.2.2.5 (CAN) In Canada, a plastic lens or light diffuser used with an air-handling luminaire shall comply with the *National Building Code of Canada*, Article 3.1.13.4.

12.2.2.5 (USA) In the United States, a plastic lens or light diffuser used with an air-handling luminaire shall:

- (a) comply with the large scale fallout test of Clause 12.2.3.2 and the impingement fire test of Clause 12.2.3.3; and
- (b) be found suitable for use without a complete frame or door, unless shipped with a complete frame or door.

## 12.2.3 Tests

### 12.2.3.1 Plastic material flame

12.2.3.1.1 A sample of the material shall be held in a jig at 30 degrees from the horizontal over a vertical test flame for 5 min, with 19.1 mm (0.75 in) of the flame in contact with the sample. The test flame shall be supplied by a Bunsen burner with a nominal 11.1 mm (0.438 in) diameter barrel, adjusted to give a 38.1 mm (1.5 in) high yellow cone with the air shut off.

12.2.3.1.2 The material shall not ignite or flame during or after the test.

### 12.2.3.2 Large scale fallout

12.2.3.2.1 The luminaire shall be mounted in a 3.6 m × 2.4 m (12 ft × 8 ft) draft-free test room with a 3 m (10 ft) ceiling. The luminaire shall be connected to an air duct with a controlled positive or negative airflow, as appropriate, of 6.8 m<sup>3</sup> (240 ft<sup>3</sup>) per minute.

12.2.3.2.2 A 53.3 cm × 53.3 cm (21 in × 21 in) steel pan, 10.2 cm (4 in) deep and 6 mm (0.25 in) thick shall be filled with alcohol to a point 5.1 cm (2 in) above the bottom of the pan. The pan shall be located 121.9 cm (4 ft) below the center of the diffuser surface, and the alcohol shall be ignited and allowed to burn until it is depleted or the diffuser falls from the luminaire.

12.2.3.2.3 The diffuser shall not ignite while it is in its intended position.

### 12.2.3.3 Impingement fire

12.2.3.3.1 Two luminaires shall be mounted with ends touching in a draft-free test room with a 3 m (10 ft) ceiling. One luminaire shall be connected to an air duct with a controlled positive or negative airflow, as appropriate, of 6.8 m<sup>3</sup> (240 ft<sup>3</sup>) per minute.

12.2.3.3.2 A 15.25 cm (6 in) diameter, 10.2 cm (4 in) deep steel container shall be filled with a minimum of 10.2 cm (4 in) of alcohol. The axial center of the pan shall be located at the center point of the diffuser edge that is farthest away from the luminaire connected to the air duct. The surface of the alcohol shall be 15.25 cm (6 in) from the diffuser. The alcohol shall be ignited and allowed to burn until it is depleted or the diffuser falls from the luminaire.

12.2.3.3.3 The flame shall not be propagated from the ignited diffuser to the adjacent diffuser.

## 12.2.4 Marking

12.2.4.1 A luminaire intended for air handling shall be marked in accordance with Table 20.1.1, Item 1.15.

12.2.4.2 A luminaire intended for handling cooled or ventilated air only shall be marked in accordance with Table 20.1.1, Item 1.16.

12.2.4.3 A light diffuser intended to be used with a luminaire shall be shipped with the luminaire.

12.2.4.3 (USA) In the United States, a luminaire that is intended to be used with a listed light diffuser but that is shipped without the diffuser shall be marked in accordance with Table 20.1.1, Item 1.11.

12.2.4.4 A plastic diffuser shall be shipped with the luminaire if it is supported by a frame integral to the luminaire.

12.2.4.4 (USA) In the United States, a plastic diffuser supported by a frame integral to the luminaire and shipped separately shall be marked in accordance with Table 20.1.1, Item 1.10.

12.2.4.5 A luminaire, intended for use as an air-handling register, with open holes in the recessed housing exceeding those specified by Clause 11.4.4 shall be marked for use in a noncombustible ceiling plenum only, in accordance with Table 20.1.1, Item 2.9.

12.2.4.6 A luminaire, intended for optional use as an air-handling register, with open holes in the recessed housing exceeding those specified by Clause 11.4.4 shall be marked for use in an environmental air-handling space other than ducts or plenums in accordance with Table 20.1.1, Item 1.18.

12.2.4.6 (MEX) In Mexico, the caution marking of Table 20.1.1, Item 1.18, is not required.

12.2.4.7 A luminaire intended for installation in environmental air-handling spaces only shall be:

- (a) constructed with all seams tight and all openings in the electrical enclosure gasketed;
- (b) provided with a gasketed fitting for field-installed metal enclosed wiring system, in accordance with Clause 11.6.2.2 (USA); and
- (c) marked in accordance with Table 20.1.1, Item 1.17.

12.2.4.7 (CAN) In Canada, the fitting and the marking specified in Clause 12.2.4.7, Items (b) and (c), shall not be required.

## 12.3 Luminaires for use above cooking equipment

### 12.3.1 General

12.3.1.1 The requirements in Clause 12.3 apply to both recessed and surface-mounted luminaires for use in exhaust ducts or hoods above cooking equipment in nonresidential occupancies.

### 12.3.2 Mechanical construction

12.3.2.1 The enclosure shall be constructed of one of the following:

- (a) steel at least 1.09 mm (0.043 in) thick;
- (b) stainless steel at least 0.94 mm (0.037 in) thick; or
- (c) other material that has been investigated and found to have equivalent mechanical strength.

12.3.2.2 An enclosure or part that serves to complete an enclosure shall be of stainless steel or steel coated with zinc or cadmium. The thickness of the coating shall be in accordance with Table 5.5.1.

12.3.2.3 The enclosure, including the diffuser and frame, shall be constructed so that cooking vapors and grease are excluded from the lamp and wiring compartments by welding, brazing, gasketing, or equivalent means.

12.3.2.4 There shall be no openings in the enclosure unless provided for the connection of an appropriate metallic wiring system or for servicing the lamp compartment. All openings shall be closed in normal use.

12.3.2.5 A means of connection for conduit shall be threaded and shall comply with Clause 6.15.2.

12.3.2.6 All mounting holes of the luminaire shall be in an external mounting foot, lug, or flange.

12.3.2.7 All mounting hardware, excluding screws, nuts, and washers, shall be mounted on the luminaire at the factory.

12.3.2.8 A light diffuser shall be of glass that is resistant to thermal and mechanical shock, in accordance with Clauses 12.3.3.2 and 12.3.3.4.

12.3.2.9 A recessed luminaire shall be provided with gasketing on the mounting surface between the luminaire and the cooking hood.

12.3.2.10 Gasket and sealing material shall be resistant to deterioration from the temperature, cooking grease, and vapors to which it will be subjected. The gasket and sealing material shall comply with the lard/fat and oil immersion test of Clause 12.3.3.6. Consideration shall be given to the irregularity of the contact surfaces, the aging, and the methods of installation of the light diffuser.

### 12.3.3 Tests

#### 12.3.3.1 Temperature

12.3.3.1.1 When tested as specified in Clause 14, a luminaire shall be mounted in a closed test compartment having a volume at least five times the approximate volume of the luminaire enclosure, and there shall be no restriction of the free flow of air inside the compartment.

12.3.3.1.2 A surface-mounted luminaire shall be suspended in the test compartment.

12.3.3.1.3 A recessed luminaire shall be enclosed in a test box constructed of nominal 12 mm (0.5 in) plywood that is reasonably tight but not sealed. The box dimensions shall be in accordance with the marking specified in Clause 12.3.4.2. The test box with the luminaire inside shall be mounted to an appropriate opening in an additional close-fitting wall inside the test compartment to simulate recessed mounting in the hood.

12.3.3.1.4 Air in the test compartment shall be maintained at a constant temperature of  $75 \pm 2$  °C or, at the manufacturer's option, the air in the test compartment may be as low as 25 °C.

12.3.3.1.5 When temperatures on the luminaire have stabilized, the full difference between the actual test ambient temperature and 75 °C shall be added to or subtracted from the observed readings.

12.3.3.1.6 The resultant temperatures shall be within the limits specified for various materials in Clause 14.

#### 12.3.3.2 Thermal shock

12.3.3.2.1 While the luminaire and diffuser are at operating temperature, the diffuser shall be subjected to a spray of water at a temperature of  $25 \pm 5$  °C. The water spray shall be created using a rubber ear syringe and shall be directed and applied normal to the surface of the diffuser at the hottest location.

12.3.3.2.2 There shall be no breaking or cracking of the diffuser that affects the integrity of the overall enclosure.

#### 12.3.3.3 Accelerated aging

12.3.3.3.1 One sample of the complete luminaire shall be exposed to a temperature of 10 °C above normal operating temperature in a circulating air oven for a period of 7 h. The normal operating temperature shall be established by the temperature test described in Clause 12.3.3.1, but in no case shall be less than 100 °C. Upon completion of this test, the mechanical abuse and sprinkler tests of Clauses 12.3.3.4 and 12.3.3.5 shall be conducted.

12.3.3.3.2 Any distortion resulting from the test shall not prevent the luminaire from continuing to operate satisfactorily, and there shall be no water leakage into the luminaire.

#### 12.3.3.4 Mechanical abuse

12.3.3.4.1 One sample of the diffuser assembly shall be subjected to an impact of 4.1 J (3 ft·lb) using the apparatus described in Clause 19.21.

12.3.3.4.2 There shall be no breakage or cracking of the material, and there shall be no water leakage into the luminaire as determined by the sprinkler test of Clause 12.3.3.5.

#### 12.3.3.5 Sprinkler

12.3.3.5.1 A surface luminaire or the exposed surface of a recessed luminaire shall comply with the sprinkler test of Clause 16.5.3.

#### 12.3.3.6 Lard/fat and oil immersion

12.3.3.6.1 Two groups of three gasket or sealing material specimens shall be tested for tensile strength and elongation both before and after immersion for 96 h. One group of specimens shall be immersed in lard or other animal fat, and the second group of specimens shall be immersed in corn oil. In all cases, the lard or other animal fat and the corn oil shall be maintained at a temperature of 100 °C.

12.3.3.6.2 After exposure, the gasket or sealing material specimens shall have a tensile strength of at least 60 percent and an elongation of at least 75 percent of the values determined before exposure.

#### 12.3.4 Marking

12.3.4.1 The luminaire shall be marked

- (a) with the minimum temperature rating of the supply wiring, in accordance with Table 20.1.1, Item 1.1;
- (b) to indicate that it may be used in a cooking hood, in accordance with Table 20.1.1, Item 2.22; and
- (c) to indicate the minimum clearance between the cooking surface and the luminaire, in accordance with Table 20.1.1, Item 2.19.

12.3.4.2 A recessed luminaire shall be marked with the minimum acceptable spacings, in accordance with Table 20.1.1, Item 1.19.

## 12.4 Elevated ambient temperature luminaires

### 12.4.1 General

12.4.1.1 The requirements in Clause 12.4 apply to luminaires intended for use in locations that experience a continuous elevated ambient temperature.

### 12.4.2 Tests

12.4.2.1 A luminaire shall:

(a) be temperature tested with a source of heated air providing the elevated temperature for which the luminaire will be marked. The maximum airflow past the luminaire shall be less than 9.1 m/min (30 ft/min). Maximum variations of 5 °C from the intended ambient temperature shall be added to or subtracted from the observed temperature readings; or

(b) fulfill the following requirements:

(1) it shall be temperature tested at an ambient temperature of  $25 \pm 5$  °C, and the full difference between the actual test ambient temperature and the intended elevated ambient temperature shall be added to the observed temperature readings; and

(2) it shall comply with the dielectric voltage-withstand test of Clause 17.1.

### 12.4.3 Marking

12.4.3.1 A luminaire intended to be used in an elevated ambient temperature shall be marked in accordance with Table 20.1.1, Item 1.6.

12.4.3.2 A luminaire may be marked in tabular form for multiple elevated ambient temperatures corresponding with supply wire temperature rating.

## 12.5 Luminaire fittings

12.5.1 A luminaire fitting shall comply with the applicable requirements in this Standard.

12.5.2 A luminaire created by assembling luminaire fittings shall comply with the applicable requirements in this Standard.

## **12.6 (CAN) Exit signs**

12.6.1 (CAN) In Canada, an exit sign shall comply with the applicable requirements of this Standard.

12.6.2 (CAN) In Canada, an exit sign shall comply with the performance requirements for lighted exit signs of CSA C22.2 No. 141.

## **13 Environmental location luminaires – supplementary requirements**

### **13.1 General**

13.1.1 The requirements in Clause 13 are supplementary to other applicable requirements in this Standard.

13.1.2 A luminaire shall be marked for a dry, damp, or wet location, as appropriate, and in accordance with Table 20.1.1, Item 2.1, Item 2.2, or Item 2.3.

13.1.3 A dry location luminaire shall not be provided with any markings, instructions, or illustrations, either on the carton or with the luminaire, that imply that it is suitable for use, or depict its use, in a damp or wet location.

### **13.2 Damp and wet location luminaires**

#### **13.2.1 General**

13.2.1.1 Damp and wet location luminaires shall have electrical insulation material with moisture-resistant properties equivalent to treated cellulosic or vulcanized fiber, phenolic, urea, or ceramic. Untreated fiber shall not be used.

13.2.1.2 The lampholder screwshells of the luminaire shall be copper, copper alloy of at least 80 percent copper, nickel alloy, or stainless steel.

### **13.3 Damp location luminaires**

#### **13.3.1 Marking**

13.3.1.1 A luminaire intended for use in damp locations that complies with the requirements of Clauses 13.2 and 13.3, as applicable, shall be marked in accordance with Table 20.1.1, Item 2.2.

13.3.1.2 A damp location luminaire shall not be provided with any markings, instructions, or illustrations, on the carton or with the luminaire, that imply that it is suitable for use, or depict its use, in a wet location.

## 13.4 Wet location luminaires

### 13.4.1 Enclosures

13.4.1.1 A luminaire shall be constructed to prevent the accumulation of water on live parts, electrical components, or conductors not identified for use in contact with water.

### 13.4.2 Corrosion protection

13.4.2.1 Copper, aluminum, alloys of copper and aluminum, stainless steel, and similar materials having inherent resistance to atmospheric corrosion may be used without additional corrosion protection.

13.4.2.2 All exposed exterior and interior surfaces of ferrous metal parts shall be protected by one of the following:

- (a) a coating of nonferrous metal applied by the hot dip process method;
- (b) a plating of nonferrous metal applied either by electro-deposition or by chemical means;
- (c) a coating of vitreous enamel;
- (d) baked paint, or similar type of coating; or
- (e) air-dry paint that complies with the paint adhesion test of Clause 16.5.12.

13.4.2.3 The requirements of Clause 13.4.2.2 shall not apply to the following:

- (a) bearings, sliding surfaces of a hinge or shaft, hinge pins, and similar parts located on the exterior of enclosures where such protection is not practicable; and
- (b) decorative parts.

13.4.2.4 Edges, punched holes, and spot welds in prefinished steel, and hanger locations for painting or plating in ferrous metal shall not require any corrosion protection.

13.4.2.5 Welds in ferrous metals shall be painted with at least one coat of outdoor paint, and spot welds in galvanized steel shall be painted with at least one coat of paint.

13.4.2.6 Vitreous enamels may be used as a protective coating for ferrous sheet metal having a minimum thickness of 0.6 mm (0.025 in).

### 13.4.3 Drain holes

13.4.3.1 A luminaire that permits water to enter the luminaire during the rain test of Clause 16.5.2 or the sprinkler test of Clause 16.5.3 shall be provided with a drain hole.

13.4.3.2 Drain holes, if provided, shall be located in the surface most likely to prevent the accumulation of water.

13.4.3.3 Drain holes shall permit the insertion of a 3.2 mm (0.125 in) diameter rod.

### 13.4.4 Water shields

13.4.4.1 A polymeric water shield shall be of a UV-rated material or shall comply with the UV exposure conditioning test of Clause 16.5.5.

13.4.4.2 A polymeric water shield that operates at a temperature higher than 65 °C, as determined by the normal temperature test of Clause 14, and that does not have a recognized temperature rating for the measured temperature shall comply with the thermal conditioning test of Clause 16.5.6.

13.4.4.3 A glass or polymeric water shield of a ground-mounted recessed luminaire shall be subjected to the impact conditioning test of Clause 16.5.7 and shall then comply with the immersion test of Clause 16.5.4.

13.4.4.4 A wooden water shield less than 13 mm (0.5 in) thick shall be subjected to the impact conditioning test of Clause 16.5.7 and shall then comply with the applicable rain, sprinkler, or immersion test.

### 13.4.5 Gaskets and bushings

13.4.5.1 A gasket or bushing required to prevent water from entering the enclosure shall be secured to prevent its loosening during user maintenance by a clip, clamping ring, adhesive, or other mechanical means.

13.4.5.2 A gasket or bushing shall be made of material as specified in Table 14.1.2, Item 20, and shall have a temperature rating suitable for the operating temperature, as determined by the normal temperature test of Clause 14, or shall withstand:

- (a) the luminaire gasket assembly accelerated aging test of Clause 16.5.8, with the gasket or bushing installed as intended in the luminaire; or
- (b) the gasket accelerated aging test of Clause 16.5.9 or 16.5.10, for the gasket or bushing only.

13.4.5.3 The adhesive that is used to secure a gasket or bushing required to prevent water from entering the enclosure and that is likely to be exposed, or not compressed as intended, during user maintenance, shall comply with:

- (a) the gasket adhesion test of Clause 16.5.11; or
- (b) the luminaire gasket assembly accelerated aging test of Clause 16.5.8, with the gasket installed in the luminaire.

13.4.6 Lampholders

13.4.6.1 Exposed, single-pin, or recessed double-contact fluorescent lampholders shall be of the weatherproof type.

13.4.7 Receptacles

13.4.7.1 A receptacle in a ground-mounted surface luminaire shall be located at least 150 mm (6 in) above ground level.

13.4.8 Tests

13.4.8.1 A luminaire identified by the location designation, LOC, in Table 13.4.8.1 and Figure 13.4.8.1 shall be evaluated in accordance with Figure 13.4.8.2. No rain or sprinkler test is required when it is readily apparent by the luminaire design that no water will enter the enclosure if the luminaire is subjected to the applicable test for the location designated.

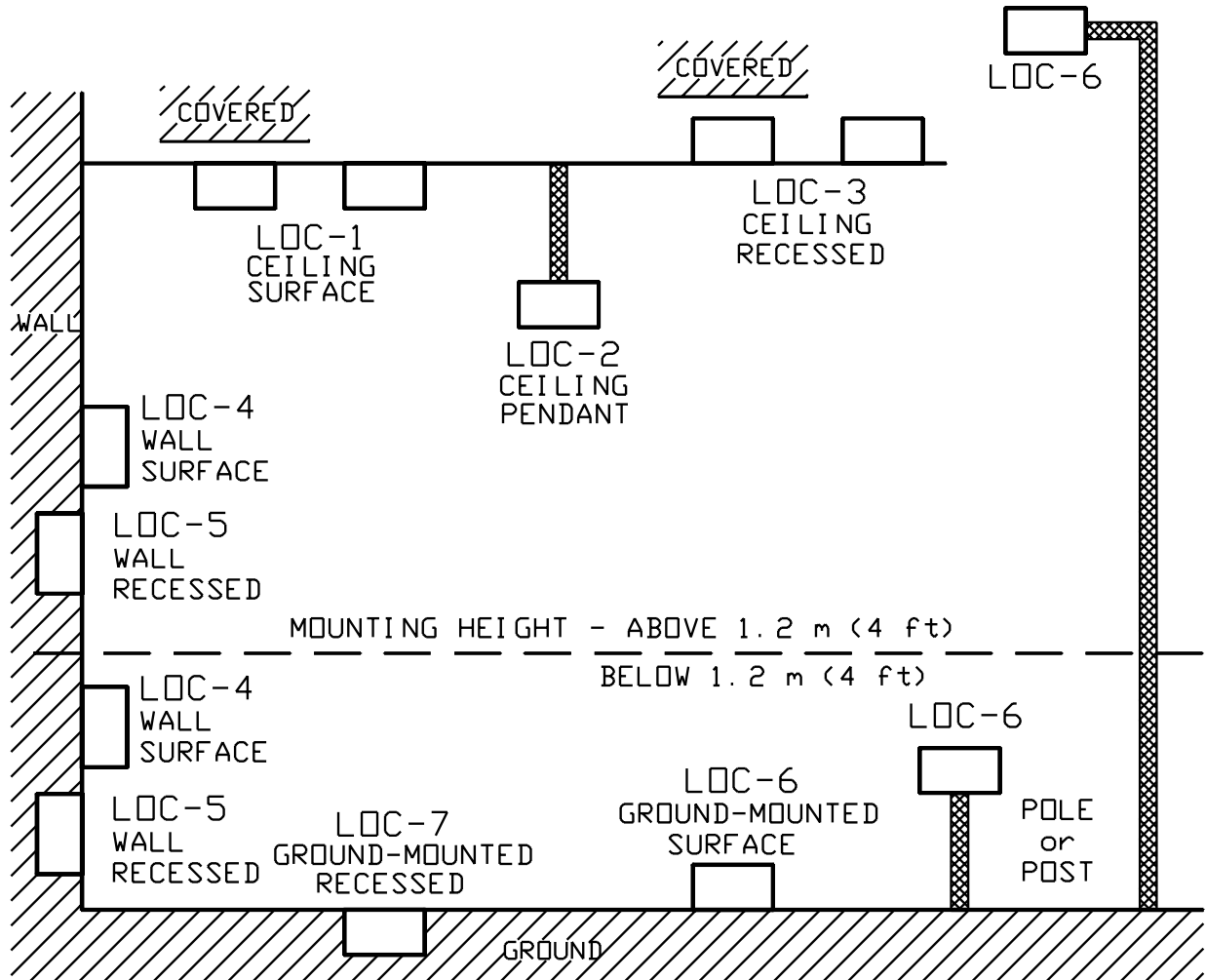
**Table 13.4.8.1  
Required tests for wet location luminaires**

(See Clause 13.4.8.1.)

Location	Luminaire location and type	Test		
		Rain	Sprinkler	Immersion
LOC-1	Ceiling-mounted surface – uncovered ceiling	Yes	No	No
LOC-1	Ceiling-mounted surface – covered ceiling only	No	Yes	No
LOC-2	Ceiling-mounted pendant	Yes	No	No
LOC-3	Ceiling-mounted recessed – uncovered ceiling	Yes	Yes	No
LOC-3	Ceiling-mounted recessed – covered ceiling only	No	Yes	No
LOC-4	Wall-mounted surface – above 1.2 m (4 ft) from ground	Yes	No	No
LOC-4	Wall-mounted surface – below 1.2 m (4 ft) from ground	Yes	Yes	No
LOC-5	Wall-mounted recessed – above 1.2 m (4 ft) from ground	Yes	No	No
LOC-5	Wall-mounted recessed v below 1.2 m (4 ft) from ground	Yes	Yes	No
LOC-6	Ground-mounted surface and pole- or post – electrical parts above 1.2 m (4 ft) from ground	Yes	No	No
LOC-6	Ground-mounted surface and pole- or post – electrical parts below 1.2 m (4 ft) from ground	Yes	Yes	No
LOC-7	Ground-mounted recessed	No	No	Yes

**Figure 13.4.8.1**  
**Luminaire location designations**

(See Clause 13.4.8.1.)

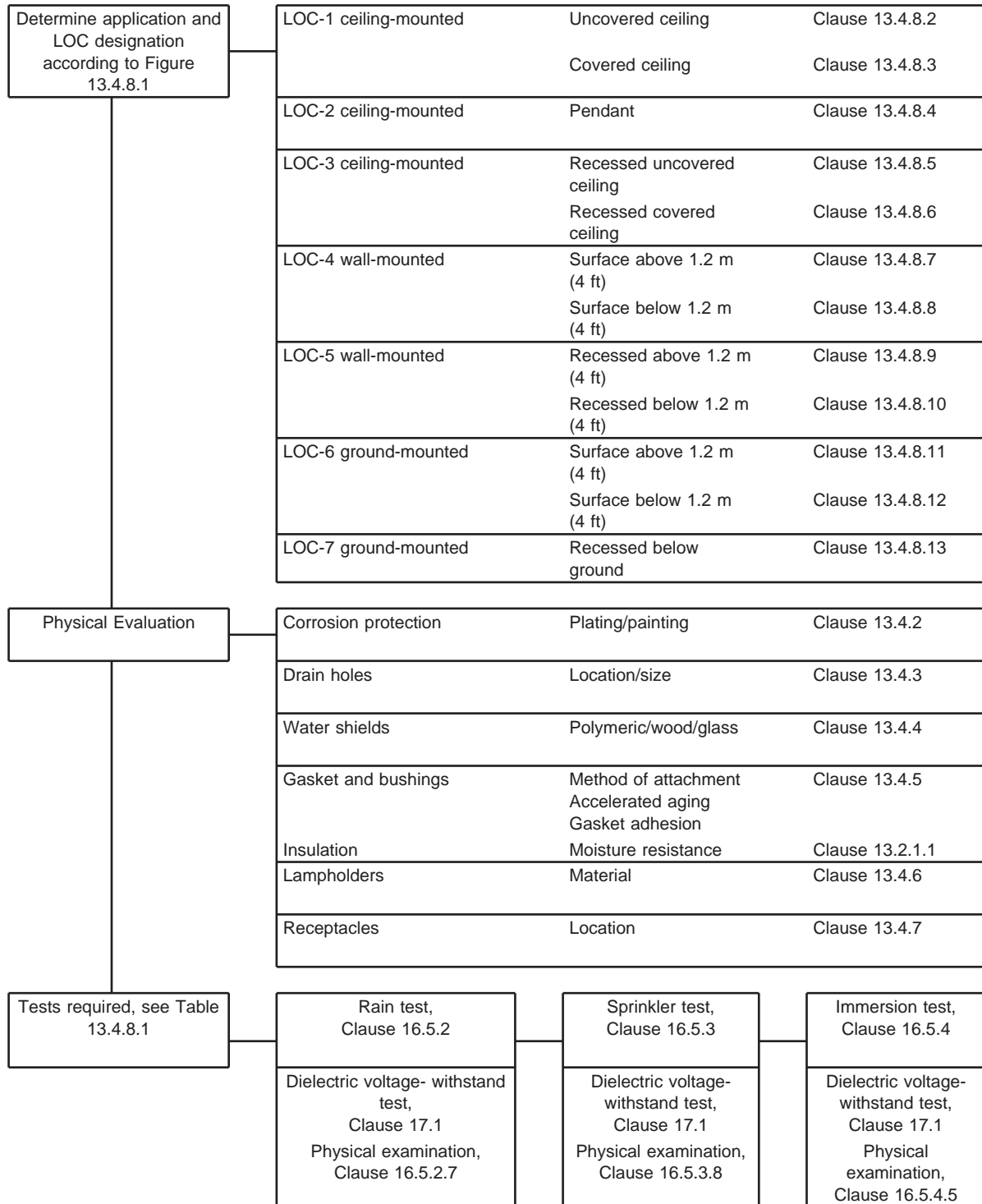


Note: LOC is the location designation.

S3810

**Figure 13.4.8.2**  
**Wet location luminaire flow chart**

(See Clause 13.4.8.1.)



13.4.8.2 A LOC-1, ceiling-mounted surface luminaire intended to be attached to an uncovered ceiling shall comply with the rain test of Clause 16.5.2.

13.4.8.3 A LOC-1, ceiling-mounted surface luminaire intended to be attached to a covered ceiling shall comply with the sprinkler test of Clause 16.5.3 and be marked for covered ceiling only, in accordance with Table 20.1.1, Item 2.11.

13.4.8.4 A LOC-2, ceiling-mounted pendant luminaire shall comply with the rain test of Clause 16.5.2.

13.4.8.5 A LOC-3, ceiling-mounted recessed luminaire intended to be attached to an uncovered ceiling shall comply with the rain test of Clause 16.5.2 and the sprinkler test of Clause 16.5.3.

13.4.8.6 A LOC-3, ceiling-mounted recessed luminaire intended to be attached to a covered ceiling only shall comply with the sprinkler test of Clause 16.5.3 and be marked for covered ceiling only, in accordance with Table 20.1.1, Item 2.11.

13.4.8.7 A LOC-4, wall-mounted surface luminaire intended to be mounted with all of the enclosure above 1.2 m (4 ft) from the ground shall comply with the rain test of Clause 16.5.2.

13.4.8.8 A LOC-4, wall-mounted surface luminaire intended to be mounted with any part of the enclosure below 1.2 m (4 ft) from the ground shall comply with the rain test of Clause 16.5.2 and the sprinkler test of Clause 16.5.3, and be marked to indicate the luminaire mounting height, in accordance with Table 20.1.1, Item 2.18.

13.4.8.9 A LOC-5, wall-mounted recessed luminaire intended to be mounted with all of the enclosure above 1.2 m (4 ft) from the ground shall comply with the rain test of Clause 16.5.2.

13.4.8.10 A LOC-5, wall-mounted recessed luminaire intended to be mounted with any part of the enclosure below 1.2 m (4 ft) from the ground shall comply with the rain test of Clause 16.5.2 and the sprinkler test of Clause 16.5.3, and be marked to indicate the luminaire mounting height, in accordance with Table 20.1.1, Item 2.18.

13.4.8.11 A LOC-6, ground-mounted surface luminaire with electrical parts located above 1.2 m (4 ft) from the ground shall comply with the rain test of Clause 16.5.2.

13.4.8.12 A LOC-6, ground-mounted surface luminaire with electrical parts located below 1.2 m (4 ft) from the ground shall comply with the rain test of Clause 16.5.2 and the sprinkler test of Clause 16.5.3, and be marked to indicate the luminaire mounting height, in accordance with Table 20.1.1, Item 2.18.

13.4.8.13 A LOC-7, ground-mounted recessed luminaire shall comply with the immersion test of Clause 16.5.4 and be marked in accordance with Table 20.1.1, Item 2.14.

13.4.9 Marking

13.4.9.1 A luminaire that is intended for use in wet locations and that complies with the requirements of Clause 13 shall be marked in accordance with Table 20.1.1, Item 2.3.

13.4.9.2 A luminaire with adjustable mounting positions that is limited or restricted to a particular position to comply with the applicable tests shall be marked to indicate the limits of adjustment or the mounting position, in accordance with Table 20.1.1, Item 1.23.

13.4.9.3 Installation instructions shall be provided for luminaires that require specific methods for sealing the mounting surface or specific fittings for supply connections, in accordance with Table 20.1.1, Item 1.33.

14 Normal temperature tests

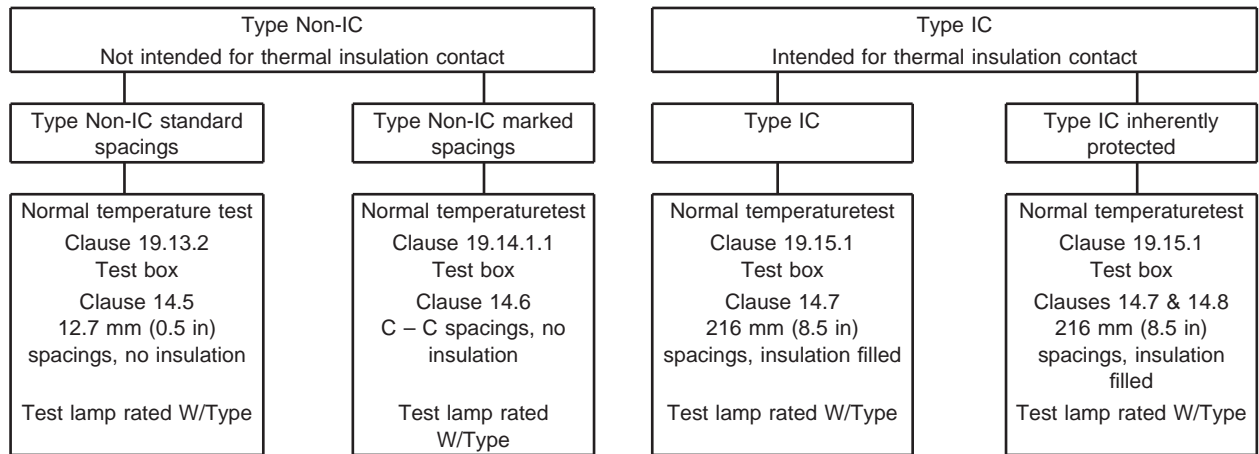
14.1 General

14.1.1 The test procedures shall be conducted in accordance with Clause 19.

14.1.2 The test procedures for Type Non-IC (not intended for thermal insulation contact) and Type IC (intended for thermal insulation contact) recessed luminaires are summarized in Table 14.1.1.

**Table 14.1.1**  
**Recessed luminaire temperature tests**

(See Clause 14.1.2.)



14.1.3 The rated wattage of any lamp used for the temperature test shall be the highest wattage rating marked on the luminaire in accordance with Clause 19.8.

14.1.4 Temperatures resulting from the normal temperature test shall not exceed the limits specified in Table 14.1.2 unless the component, material, or compound has been investigated and found acceptable for a higher temperature.

**Table 14.1.2**  
**Maximum temperature limits**  
(See Clauses 6.13.2.2, 11.8.1.3, 13.4.5.2, 14.1.4, 14.2.9, 14.3.5, 14.4.4, 14.5.5, 14.6.5, 14.7.5, 14.8.3, 14.9.3, 15.2.6, 15.2.7, 15.3.1.6, 15.3.1.7, and 19.2.3.)

Item	Location	Maximum, °C, thermocouple method	Maximum, °C, rise- of- resistance method
1	Copper or aluminum current-carrying parts of a lampholder	200	
2	Nickel plated copper current-carrying parts of a lampholder	250	
3	Nickel alloy current-carrying parts of a lampholder	315	
4	Luminaire conductors	Rated	
5	(CAN) Outlet box supply conductors for dwellings – wall mount	75	
	(USA) Outlet box supply conductors for dwellings – wall mount	90	
	Outlet box supply conductors for dwellings – ceiling mount	90	
6	Outlet box supply conductors – other than dwellings	200	
7	Termination of copper conductors and pressure terminal conductors without a nickel coating or equivalent protection	150	
8	Enclosure of an enclosed and potted coil device employing:		
	Class 105 insulation system	90	
	Class 130 insulation system	110	
	Class 155 insulation system	135	
	Class 180 insulation system	150	
9	Coil of a device employing:		
	Class 105 insulation system	90	100
	Class 130 insulation system	110	120
	Class 155 insulation system	135	145
	Class 180 insulation system	150	165
	Class 200 insulation system	170	185
	Class 220 insulation system	185	200
	Class 250 insulation system	215	230
10	Resistor-type ballast	150	
11	Capacitor (unless rated, or marked otherwise)	90	
12	Enclosure of automatic starter for fluorescent lamp	80	
13	Enclosure of automatic starter for HID lamp	90	
14	Fuse	90	
15	Recessed luminaire enclosure (Type Non-IC)	150	
16	Recessed luminaire enclosure (Type IC)	90	
17	Combustible structural building parts including recessed test box	90	
18	Noncombustible structural building part	150	

Table 14.1.2 Continued on Next Page

Table 14.1.2 Continued

Item	Location	Maximum, °C, thermocouple method	Maximum, °C, rise- of- resistance method
19	Electrical insulating materials: Phenolic Silicone rubber (not stressed) Silicone rubber (compressed) Neoprene rubber (dry locations) Neoprene rubber (oil or wet locations) Rubber (ordinary) Melamine Nylon (polyamide) Paper, wood, ordinary fiber Urea Varnished cloth insulation Vulcanized fiber	150 200 170 90 60 60 130 105 90 100 85 90	
20	Non-electrical insulating materials: Silicone rubber EPDM Neoprene rubber Rubber (ordinary) Paper, wood, cork, or other fibrous material Polyethylene PVC Acrylic Polycarbonate Non-thermosetting sealing compound	230 90 90 70 90 60 60 65 75 Rated	
21	Other thermoplastic and thermosetting plastic	50	
22	Thermoplastic body of fluorescent lampholder <sup>a</sup>	90	
<sup>a</sup> A fluorescent lampholder fabricated from thermoplastic having a relative thermal index with impact exceeding 90° C at a thickness equal to that used in the lampholder construction, has a temperature limit equal to that relative thermal index.			

**14.2 Surface ceiling luminaires**

14.2.1 A luminaire that appears to be suitable for either ceiling or wall mounting shall be tested as one of the following:

- (a) a ceiling-mounted luminaire; or
- (b) a wall-mounted luminaire and shall be marked for wall mounting only, in accordance with Table 20.1.1, Item 2.10.

14.2.2 A luminaire shall be mounted on the test apparatus specified in Clause 19.10, directly under the outlet box, in the intended manner.

14.2.3 A pendant-mounted luminaire shall be tested when attached to the test ceiling with the shortest length of cord, chain, or stem permitted by the luminaire design.

14.2.4 A luminaire that can be pendant mounted or mounted directly to the ceiling shall be tested while mounted directly to the test ceiling.

14.2.5 A luminaire marked for installation on a noncombustible surface only shall be mounted on the test ceiling as shown in Figure 19.10.1, without thermal insulation.

14.2.6 Thermocouples shall be attached to the test ceiling in locations where the highest temperatures are likely to occur, including:

- (a) the point where the luminaire contacts the test ceiling; and
- (b) directly over the point that is closest to the highest source of heat.

14.2.7 Supply conductor temperatures in the outlet box shall be measured using the temperature test probe shown in Figure 19.9.1. The probe shall be mounted to the outlet box ears with the copper surface facing the interior of the box.

14.2.8 The test lamp shall comply with the requirements of Clause 19.8.

14.2.9 The resulting temperatures shall not exceed those specified in Table 14.1.2, except as permitted by Clause 14.1.4, and any integral thermal protector shall not operate.

### **14.3 Surface wall luminaires**

14.3.1 A luminaire shall be mounted on the test apparatus of Clause 19.11, directly over the outlet box, in the intended manner.

14.3.2 Thermocouples shall be attached to the test wall in locations where the highest temperatures are likely to occur, including:

- (a) the point where the luminaire contacts the test wall; and
- (b) directly adjacent to the point that is closest to the highest source of heat.

14.3.3 Supply conductor temperatures in the outlet box shall be measured using the temperature test probe shown in Figure 19.9.1. The probe shall be mounted to the outlet box ears with the copper surface facing the interior of the box.

14.3.4 The test lamp shall comply with the requirements of Clause 19.8.

14.3.5 The resulting temperatures shall not exceed those specified in Table 14.1.2, except as permitted by Clause 14.1.4, and any integral thermal protector shall not operate.

#### 14.4 Under-cabinet luminaires

14.4.1 A luminaire shall be mounted in the test alcove of Clause 19.12, in contact with the two walls and top of the alcove.

14.4.2 Thermocouples shall be attached to the test alcove in locations where the highest temperatures are likely to occur, including:

- (a) the points where the luminaire contacts the walls and top of the alcove; and
- (b) directly adjacent to the point that is closest to the highest source of heat.

14.4.3 The test lamp shall comply with the requirements of Clause 19.8.

14.4.4 The resulting temperatures shall not exceed those specified in Table 14.1.2, except as permitted by Clause 14.1.4, and any integral thermal protector shall not operate.

#### 14.5 Type Non-IC recessed luminaires (not intended for thermal insulation contact)

14.5.1 A Type Non-IC luminaire shall comply with the normal temperature test of Clauses 14.5.2 to 14.5.5.

14.5.2 The test lamp type and wattage shall be as follows:

- (a) for fluorescent luminaires, as marked on the ballast, unless marked otherwise on the luminaire;
- (b) for incandescent luminaires, as marked on the luminaire
  - (1) for Type B, T, and PS lamps, as specified in Clause 19.8 and Table 19.8.1;
  - (2) for Type A or reflector lamps, as specified in Clause 19.8 and Table 19.8.2; or
  - (3) for MR lamps, as specified in Clause 19.8; and
- (c) for HID luminaires, as marked on the luminaire and as specified in Clause 19.8.

14.5.3 A luminaire shall be installed in a test box as specified in Clause 19.13 in the configuration that results in the highest operating temperatures, considering different trim and maximum lamp wattage combinations specified in the lamp replacement markings, lampholder adjustment heights, and the like.

14.5.4 A luminaire marked for use with through wiring shall be tested in accordance with Clause 14.10 at the same time the normal temperature test is conducted.

14.5.5 The resulting temperatures shall not exceed those specified in Table 14.1.2, and any integral thermal protector shall not operate.

**14.6 Type Non-IC marked spacings luminaires (not intended for thermal insulation contact)**

14.6.1 A marked spacings incandescent or HID luminaire shall comply with the normal temperature tests of Clauses 14.6.2 to 14.6.5.

14.6.2 The test lamp type and wattage shall be as follows:

- (a) for incandescent luminaires, as marked on the luminaire
  - (1) for Type B, T, and PS lamps, as specified in Clause 19.8 and Table 19.8.1; or
  - (2) for Type A or reflector lamps, as specified in Clause 19.8 and Table 19.8.2; or
  - (3) for MR lamps, as specified in Clause 19.8; and
- (b) for HID luminaires, as marked on the luminaire and as specified in Clause 19.8.

14.6.3 A luminaire shall be installed in a test box as described in Clause 19.14 in the configuration that results in the highest operating temperatures, considering different trims, lampholder adjustment heights, and the like.

14.6.4 A luminaire marked for use with through wiring shall be tested in accordance with Clause 14.10 at the same time the normal temperature test is conducted.

14.6.5 The resulting temperatures shall not exceed those specified in Table 14.1.2, and any integral overheating protective device shall not operate.

**14.7 Type IC recessed luminaires (intended for thermal insulation contact)**

14.7.1 A Type IC luminaire shall comply with the normal temperature tests of Clauses 14.7.2 to 14.7.5.

14.7.2 The test lamp type and wattage shall be as follows:

- (a) for fluorescent luminaires, as marked on the ballast, unless marked otherwise on the luminaire;
- (b) for incandescent luminaires, as marked on the luminaire
  - (1) for Type B, T, and PS lamps, as specified in Clause 19.8 and Table 19.8.1; or
  - (2) for Type A or reflector lamps, as specified in Clause 19.8 and Table 19.8.2; or
  - (3) for MR lamps, as specified in Clause 19.8; and
- (c) for HID luminaires, as marked on the luminaire and as specified in Clause 19.8.

14.7.3 A luminaire shall be installed in a test box as described in Clause 19.15 in the configuration that results in the highest operating temperatures, considering different trims, lampholder adjustment heights, and the like. All spaces around the luminaire and between it and the sides of the test box shall be filled with the thermal insulation described in Clause 19.16.

14.7.4 A luminaire marked for use with through wiring shall be tested in accordance with Clause 14.10 simultaneously with the normal temperature test.

14.7.5 The resulting temperatures shall not exceed those specified in Table 14.1.2, and any integral overheating protective device shall not operate.

#### **14.8 Type IC inherently protected recessed luminaires (intended for thermal insulation contact)**

14.8.1 A Type IC inherently protected luminaire shall comply with the normal temperature test of Clause 14.7 and Clauses 14.8.2 to 14.8.4.

14.8.2 The test lamp shall be the highest wattage lamp of any type that can be installed in the luminaire.

14.8.3 The resulting temperatures shall not exceed those specified in Table 14.1.2.

14.8.4 A luminaire marked for use with through wiring shall be tested in accordance with Clause 14.10 simultaneously with the normal temperature test.

#### **14.9 Recessed luminaires for use in poured concrete**

14.9.1 A luminaire marked for use in concrete shall comply with the normal temperature test of Clause 14.5, using the installation method of Clause 14.9.2 and the requirements of Clause 14.9.3.

14.9.2 A luminaire shall be installed as intended in concrete. The minimum thickness of the concrete shall be 150 mm (6 in) from any point on the recessed housing. At the option of the luminaire manufacturer, 30 mesh dry builder's sand may be substituted for the concrete.

14.9.3 The resulting temperatures shall not exceed those specified in Table 14.1.2.

#### **14.10 Through-wiring junction box temperature**

14.10.1 The through wiring junction box temperature test simulates the heating effect of actual loading conditions and shall be performed simultaneously with the applicable normal temperature test of Clause 14.

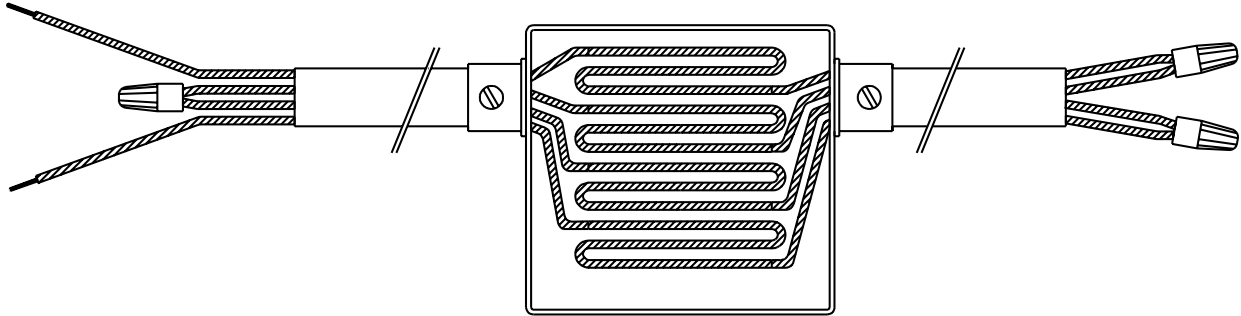
14.10.2 Two lengths of electrical metallic tubing or flexible metallic conduit, suitable for the number and size of the through branch circuit conductors, shall be attached to the outlet box with the appropriate fittings. The lengths of raceway shall extend approximately 300 mm (12 in) outside of the test box.

14.10.3 The test conductors placed in the outlet box shall be Type TW, TEW, or THHN and shall correspond to the number and size of the branch circuit conductors marked on the luminaire in accordance with Table 20.1.1, Item 1.40.

14.10.4 For each two conductors marked on the luminaire, an amount of test conductor equal to the length of the box or 300 mm (12 in), whichever is greater, shall be placed inside the junction box by winding it back and forth as shown in Figure 14.10.1.

**Figure 14.10.1**  
**Test conductor installation for through-wiring junction box temperature test**

(See Clause 14.10.4.)



S3824

14.10.5 The conductors shall be connected in series outside the raceway, and a separate supply source of any convenient voltage shall be connected and operated at 80 percent of the conductor's rated ampacity. The outer ends of the raceways shall be plugged to prevent air circulation.

14.10.6 The temperature of the test conductors shall not exceed or be able to contact a surface that exceeds the branch circuit conductor rating marked on the luminaire.

**14.11 Raceway temperature**

14.11.1 The raceway temperature test simulates the heating effect of actual loading conditions and shall be performed simultaneously with the applicable normal temperature test of Clause 14.

14.11.2 The luminaire shall be operated with the maximum number, type, and size of conductors installed in the raceway as marked on the luminaire in accordance with Table 20.1.1, Item 1.40.

14.11.3 The conductors shall be connected in series outside the raceway, and a separate supply source of any convenient voltage shall be connected and operated at 80 percent of the conductor ampacity rating. The outer ends of the raceways shall be plugged to prevent air circulation.

14.11.4 The temperature of the test conductors shall not exceed or be able to contact a surface that exceeds the branch circuit conductor rating marked on the luminaire.

**14.12 (MEX) Temperature rise**

14.12.1 (MEX) In Mexico, the temperature increase in normal operating conditions shall be determined by the procedures described in Clause 19.6 (MEX).

14.12.2 (MEX) In Mexico, the temperature increase in normal operating conditions shall not be more than the limits stated in Table 14.12.1 (MEX), and the temperatures obtained in the insulated conductors and connectors shall not be more than the limits indicated in Table 14.12.2 (MEX).

**Table 14.12.1 (MEX)  
Maximum temperature**

(See Clause 14.12.2 (MEX).)

Item	Location	Maximum, °C, thermocouple method	Maximum, °C, rise-of-resistance method
1	Possible contact point of supply leads within luminaire (Note 1)	60	
2	Coil of a device employing: Class 105 insulation system Class 130 insulation system Class 155 insulation system Class 180 insulation system Class 200 insulation system	90 110 135 150 170	95 120 140 165 185
3	Capacitor cases, unless rated or marked otherwise (Note 2)	80	
<p>NOTES</p> <p>(1) The temperature may be exceeded as long as the luminaire is labelled in accordance with Clause 12.1, Item h, of NOM-064-SCFI.</p> <p>(2) Increase in temperature in the capacitor may exceed the limit indicated if the capacitor is adequate for such a temperature.</p>			

**Table 14.12.2 (MEX)**  
**Insulation of wire splices**

(See Clauses 6.18.2 (MEX) and 14.12.2 (MEX).)

Operating temperature of wire splice insulation	Materials commonly used
Less than or equal to 80 °C	Thermoplastic tape, insulating tape made of cotton, or oil cloth should be secured in place by winding it on the outside with cotton adhesive tape or any similar material.
Greater than 80 °C	Adequate connectors or insulators for the operating temperature
NOTE The maximum temperature to which a wire splice is exposed shall be determined by placing a thermocouple on the outside of the insulation and shall be in accordance with the marking as described in Clause 20.1.	

14.12.3 (MEX) In Mexico, the values of temperature rise in Table 14.12.1 (MEX) shall be based on ambient temperature of 25 °C, and the tests shall be conducted at an ambient temperature of  $25 \pm 5$  °C. The ambient temperature sensor shall be located at the height of the luminaire, but not in the direct light of the luminaire. The variances above or below 25 °C shall be subtracted or added, respectively.

14.12.4 (MEX) In Mexico, temperature readings for determining compliance with Table 14.12.1 (MEX) shall be obtained using thermocouples or equivalent equipment, except for windings, including those encapsulated on which you must apply the resistance method described in NMX-J-230-ANCE or NMX-J-198-ANCE. A temperature shall be considered stable when three successive measurements taken at 15 min intervals do not change more than 1 °C.

## 15 Abnormal temperature tests

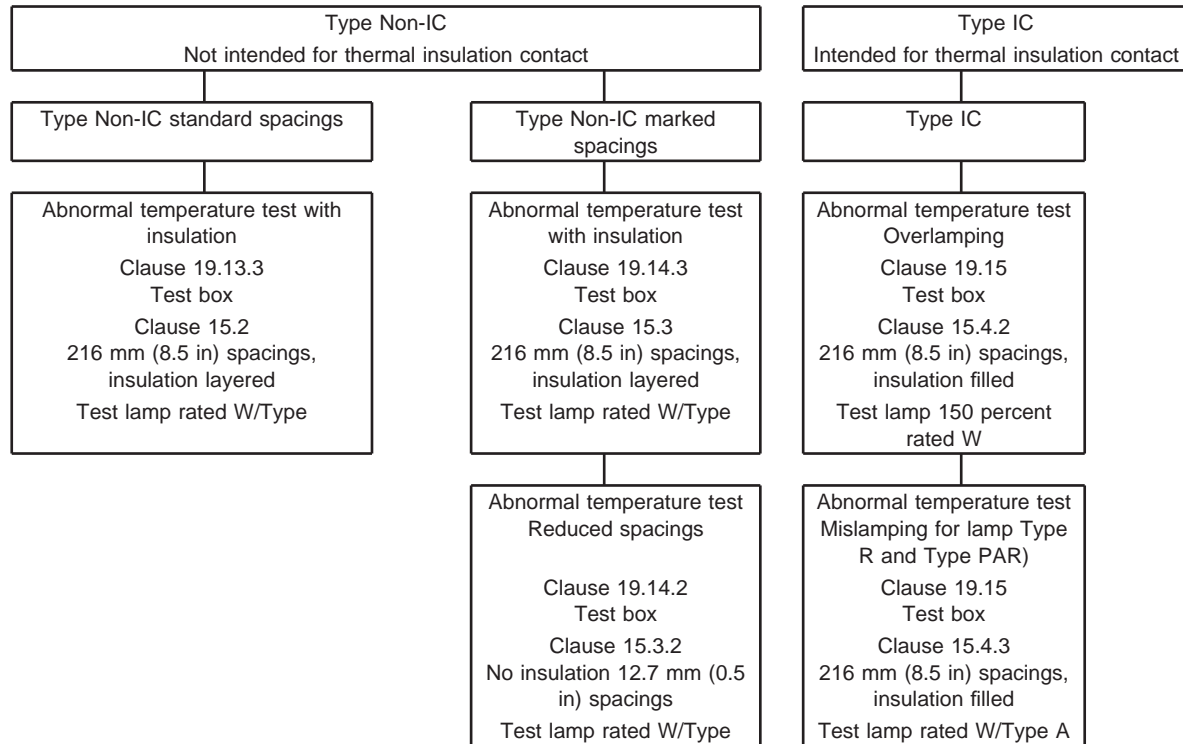
### 15.1 General

15.1.1 The test procedures shall be conducted in accordance with Clause 19.

15.1.2 The test procedures for Type Non-IC (not intended for thermal insulation contact) and Type IC (intended for thermal insulation contact) recessed luminaires are summarized in Table 15.1.1.

15.1.3 Through-wiring, if installed, shall not be energized.

**Table 15.1.1**  
**Recessed luminaire abnormal temperature tests**  
 (See Clause 15.1.2.)



**15.2 Type Non-IC recessed luminaires (not intended for thermal insulation contact)**

15.2.1 A test box shall be constructed as specified in Clause 19.13.3.

15.2.2 A luminaire shall be installed in the test box in the normal temperature test configuration of Clause 14.5 that results in the lowest operating temperatures on luminaire surfaces that contact the test box or that can contact thermal insulation.

15.2.3 For ceiling-mounted luminaires, the thermal insulation specified in Clause 19.16 shall be placed around the luminaire in the test box as follows:

- (a) the initial depth of the thermal insulation shall be 100 mm (4 in) above the bottom of the test box or 50 mm (2 in) above the lowest glass portion of the test lamp, whichever is higher;
- (b) the initial depth of the insulation shall not exceed the height of the lamp compartment; and
- (c) if more than one test iteration is required to achieve the results specified in Clause 15.2.7, an additional 50 mm (2 in) of thermal insulation shall be added for each successive iteration. The last increase in thermal insulation may be less than a 50 mm (2 in) increment, to ensure that the maximum 216 mm (8.5 in) height requirement is not exceeded. For each additional thermal insulation level, the test shall be restarted with all temperatures at room ambient.

15.2.4 For recessed wall-mounted luminaires, the thermal insulation specified in Clause 19.16 shall be placed over a recessed luminaire mounted in the test wall so the topmost portion of the luminaire is under 216 mm (8.5 in) of thermal insulation.

15.2.5 The test lamp type and wattage for:

- (a) an incandescent luminaire shall be as marked on the luminaire and as specified in Clause 19.8 and Table 19.8.2; and
- (b) an HID luminaire shall be as marked on the luminaire and ballast, and as specified in Clause 19.8.

15.2.6 A luminaire shall be operated until the thermal protector trips or for a maximum of 7.5 h. If the protector does not trip within 3 h, the test shall be repeated with an additional 50 mm (2 in) of thermal insulation, until:

- (a) the thermal protector trips within 3 h; or
- (b) the temperature limits in Table 14.1.2 are exceeded; or
- (c) the thermal insulation height is 216 mm (8.5 in) above the highest projection of the luminaire, the thermal protector does not operate, and the temperature limits are not exceeded, in which case the test shall be repeated with the next hotter trim installed.

15.2.7 Test results shall be acceptable if the thermal protector:

- (a) operates within 3 h and no part of the luminaire in contact with thermal insulation or the test box exceeds 160 °C; or
- (b) does not operate within 3 h and the temperature limits specified in Table 14.1.2 are not exceeded during the test. Any part of the luminaire in contact with thermal insulation or the test box shall not exceed 90 °C. The test shall be terminated after 7.5 h.

### **15.3 Type Non-IC marked spacings incandescent and HID recessed luminaires (not intended for thermal insulation contact)**

15.3.1 Abnormal insulation temperature

15.3.1.1 A test box shall be constructed as specified in Clause 19.14.3.

15.3.1.2 A luminaire shall be installed in the test box in the normal temperature test configuration of Clause 14.5 that results in the lowest operating temperatures on luminaire surfaces that contact the test box or that can contact thermal insulation.

15.3.1.3 For ceiling-mounted luminaires, the thermal insulation specified in Clause 19.16 shall be placed around the luminaire in the test box as follows:

- (a) the initial depth of the thermal insulation shall be 100 mm (4 in) above the bottom of the test box or 50 mm (2 in) above the lowest glass portion of the test lamp, whichever is higher;
- (b) no thermal insulation shall be initially placed on top of the lamp compartment; and

(c) if more than one test iteration is required to achieve the results specified in Clause 15.2.7, an additional 50 mm (2 in) of thermal insulation shall be added for each successive iteration. The last increase in thermal insulation may be less than a 50 mm (2 in) increment, to ensure that the maximum 216 mm (8.5 in) height requirement is not exceeded. For each additional thermal insulation level, the test shall be restarted with all temperatures at room ambient.

15.3.1.4 For wall-mounted luminaires, the thermal insulation specified in Clause 19.16 shall be placed over a wall mounted luminaire so the topmost portion of a luminaire recessed in the test wall is under 216 mm (8.5 in) of thermal insulation.

15.3.1.5 The test lamp type and wattage for:

(a) an incandescent luminaire shall be as marked on the luminaire and as specified in Clause 19.8 and Tables 19.8.1 and 19.8.2; and

(b) an HID luminaire shall be as marked on the luminaire and ballast, and as specified in Clause 19.8.

15.3.1.6 A luminaire shall be operated until the thermal protector trips or for a maximum of 7.5 h. If the protector does not trip within 3 h, the test shall be repeated with an additional 50 mm (2 in) of thermal insulation, until:

(a) the thermal protector trips within 3 h; or

(b) the temperature limits in Table 14.1.2 are exceeded; or

(c) the thermal insulation height is 216 mm (8.5 in) above the highest projection of the luminaire.

15.3.1.7 Test results shall be acceptable if the thermal protector:

(a) operates within 3 h and no part of the luminaire in contact with thermal insulation or the test box exceeds 160 °C; or

(b) does not operate within 3 h and the temperature limits specified in Table 14.1.2 are not exceeded during the test. Any part of the luminaire in contact with thermal insulation or the test box shall not exceed 90 °C. The test shall be terminated after 7.5 h.

### 15.3.2 Reduced spacings abnormal temperature

15.3.2.1 The test shall be conducted as specified in Clause 14.5.

15.3.2.2 Test results shall be acceptable if the thermal protector:

(a) operates within 3 h and no part of the luminaire in contact with the test box exceeds 160 °C; or

(b) does not operate within 3 h and the temperature of any part of the luminaire in contact with the test box is 90 °C or less. The test shall be terminated after 7.5 h.

## 15.4 Type IC incandescent recessed luminaires (intended for thermal insulation contact)

### 15.4.1 General

15.4.1.1 A Type IC recessed incandescent luminaire shall comply with the abnormal overlamping and mislamping temperature tests described in Clauses 15.4.2 and 15.4.3, unless constructed as described in Clause 15.4.1.2.

15.4.1.2 A Type IC incandescent luminaire with a thermal protector rated  $110 \pm 5$  °C or less and located within 38 mm (1.5 in) of the geometric center of the top shall be exempted from the tests specified in Clause 15.4.1.1.

### 15.4.2 Overlamping

15.4.2.1 A test box shall be constructed as specified in Clause 19.15.

15.4.2.2 A luminaire shall be installed in the test box in the configuration that resulted in the lowest operating temperatures on luminaire surfaces in contact with the test box or thermal insulation during the normal temperature test described in Clause 14.7.

15.4.2.3 The abnormal test box shall be filled with the thermal insulation specified in Clause 19.16.

15.4.2.4 A luminaire shall be tested with a lamp in accordance with Table 19.8.3 and shall have the voltage adjusted to operate the lamp at rated wattage.

15.4.2.5 A luminaire rated for lamps that are not included in Table 19.8.3 shall be tested with a lamp of the same type used in the normal temperature test that is either:

(a) 150 percent of the specified lamp wattage; or

(b) the next higher common lamp rating more than 150 percent of specified wattage.

15.4.2.6 The test shall not be required to be conducted under the following conditions:

(a) the test lamp cannot fit into the luminaire with the trim installed; or

(b) no higher lamp wattage exists.

15.4.2.7 For a luminaire that has more than one lamp type, the abnormal test shall be conducted separately for each lamp type and for each lamp of a multi-lamp luminaire.

15.4.2.8 A luminaire shall be operated until the thermal protector trips or for a maximum of 7.5 h. If the thermal protector does not open within 3 h and the temperatures on the luminaire surfaces in contact with thermal insulation and points of support are less than 90 °C, the test shall be repeated with the next higher wattage lamp. If there is no higher wattage lamp or if the lamp will not fit, the test shall be repeated with the lamp and the trim that resulted in the next higher recessed housing temperature or point-of support temperature, or both, during the normal temperature test. Each iteration shall start with the luminaire at room ambient temperature. This process shall be repeated until

- (a) the thermal protector trips within 3 h; or
- (b) there is no higher wattage lamp; or
- (c) the next higher wattage lamp does not fit in the luminaire; or
- (d) there are no trims that result in the luminaire operating at a higher temperature.

15.4.2.9 If the thermal protector does not open in 3 h, and the temperatures on the luminaire surfaces in contact with thermal insulation and points of support are greater than 90 °C, but less than 20 °C above the temperatures measured on these same points during the normal temperature test, the test procedure in Clause 15.4.2.10 shall be performed.

15.4.2.10 The following test procedure shall be performed on a luminaire that complies with Clause 15.4.2.9 after the luminaire has reached thermal stabilization:

- (a) defeat (short) the thermal protector;
- (b) increase the supply voltage to 5 V above that required to make the lamp operate at rated wattage;
- (c) operate the luminaire and measure the temperature of points of the luminaire in contact with thermal insulation and points of support after 15 min;
- (d) if the temperatures measured are less than 20 °C above the temperature measured at that point during the normal temperature test, return to the point in the procedure described in Item (b) and raise the supply voltage another 5 V; and
- (e) when any of the temperatures measured in Item (c) exceed the temperature measured at that point during the normal temperature test by 20 °C:
  - (1) record the supply voltage;
  - (2) de-energize the luminaire and let it cool to room ambient temperature;
  - (3) reconnect the thermal protector;
  - (4) connect the luminaire to a supply adjusted to the voltage recorded in Item (1) and let it operate; and
  - (5) apply Clauses 15.4.2.8 and 15.4.2.11.

15.4.2.11 Test results shall be acceptable if the thermal protector:

(a) operates within 3 h and the temperature of any part of the luminaire in contact with thermal insulation or the test box does not exceed 160 °C; or

(b) does not operate within 3 h, the test is continued for 7.5 h, and the temperature of any part of the luminaire in contact with thermal insulation or the test box does not exceed 90 °C.

#### 15.4.3 Mislamping

15.4.3.1 The test box shall be constructed as described in Clause 19.15.

15.4.3.2 A luminaire shall be installed in the test box in the configuration that resulted in the lowest operating temperatures on luminaire surfaces in contact with the test box or thermal insulation during the normal temperature test, in Clause 14.7.

15.4.3.3 The test box shall be filled with the thermal insulation specified in Clause 19.16.

15.4.3.4 A luminaire marked for use with a reflector-type lamp shall be tested with a Type A lamp of the same wattage or the next higher wattage. Whenever possible, standard incandescent test lamps specified in Table 19.8.2 shall be used.

15.4.3.5 For a luminaire that has more than one lamp, the mislamping test shall be conducted separately for each lamp.

15.4.3.6 The test shall be continued until:

(a) the thermal protector trips;

(b) the temperature limits are exceeded; or

(c) 7.5 h has elapsed, and there are no trims that result in the luminaire operating at a higher temperature.

15.4.3.7 If the thermal protector does not open within 3 h, and the temperatures on the luminaire surfaces in contact with thermal insulation and the points of support are less than 90 °C, the test shall be repeated with the trim that resulted in the next higher recessed housing temperature or point-of support temperature, or both, during the normal temperature test. Each iteration shall start with the luminaire at room ambient temperature.

15.4.3.8 If the thermal protector does not open in 3 h and the temperatures on the luminaire surfaces in contact with thermal insulation and the points of support are more than 90 °C, but less than 20 °C above the temperatures measured on these same points during the normal temperature test, the test procedure in Clause 15.4.3.9 shall be performed.

15.4.3.9 Perform the following test procedure on a luminaire that complies with Clause 15.4.3.8 after the luminaire has reached thermal stabilization:

(a) defeat the thermal protector;

(b) increase the supply voltage to 5 V above that required to make the lamp operate at rated wattage;

- (c) operate the luminaire and measure the temperature of points of the luminaire in contact with thermal insulation and points of support after 15 min;
- (d) if the temperatures measured are less than 20 °C above the temperature measured at that point during the normal temperature test, return to the point in the procedure described in Item (b) and raise the supply voltage another 5 V; and
- (e) when any of the temperatures measured in Item (c) exceed the temperature measured at that point during the normal temperature test by 20 °C:
  - (1) record the supply voltage;
  - (2) de-energize the luminaire and let it cool to room ambient temperature;
  - (3) reconnect the thermal protector;
  - (4) connect the luminaire to a supply adjusted to the voltage recorded in Item (1) and let it operate; and
  - (5) apply Clauses 15.4.3.6 and 15.4.3.10.

15.4.3.10 Test results shall be acceptable if the thermal protector:

- (a) operates within 3 h and the temperature of any part of the luminaire in contact with thermal insulation or the test box does not exceed 160 °C; or
- (b) does not operate within 3 h, the test is continued for 7.5 h, and the temperature of any part of the luminaire in contact with thermal insulation or the test box does not exceed 90 °C.

## **15.5 Abnormal overlamping operation test for incandescent luminaires with polymeric housings or enclosures**

15.5.1 A luminaire shall be operated as specified in the normal temperature test, with the largest possible wattage lamp the luminaire accommodates, for 7.5 h.

15.5.2 There shall be no ignition of the polymeric material or exposure of live parts. Shrinkage, warpage, expansion, or cracking shall be acceptable.

## **16 Mechanical tests**

### **16.1 Barrier strength**

16.1.1 A sample luminaire with the barrier mounted as intended shall be tested.

16.1.2 A force of 44.5 N (10 lb) over an area of 6.45 cm<sup>2</sup> (1 in<sup>2</sup>) shall be applied to the barrier for 1 min.

16.1.3 The application of the force shall not result in

- (a) permanent distortion of a metal barrier;
- (b) temporary or permanent reduction of electrical spacings; or
- (c) breaking or cracking of a nonmetallic barrier.

## 16.2 Metal thickness equivalency

### 16.2.1 General

16.2.1.1 A luminaire having reduced metal thickness shall comply with the compression and impact tests described in Clauses 16.2.2 and 16.2.3. Pendant-mounted luminaires having reduced metal thickness shall additionally comply with the flexing, and the torque and cantilever tests described in Clauses 16.2.4 and 16.2.5.

### 16.2.2 Compression

16.2.2.1 The luminaire shall be tested as follows:

- (a) the luminaire shall be placed on a flat horizontal surface.
- (b) a 111 N (25 lb) force shall be applied, using a rod with a 25.4 mm (1 in) diameter face, to the center of the surface being tested for 1 min.

16.2.2.2 Test results shall be acceptable if:

- (a) the electrical spacings comply with Clause 6.11; and
- (b) the accessibility of uninsulated live parts complies with Clause 6.13.2.

### 16.2.3 Impact

16.2.3.1 The sample luminaires shall be held in place and subjected to a single 7 J (5 ft·lb) impact, using the impact test apparatus described in Clause 19.21, falling through a vertical height of 1.29 m (4.24 ft), on surfaces being tested.

16.2.3.2 The number of samples and the sequence of the procedure shall be in accordance with Figure 16.2.3.1.

**Figure 16.2.3.1**  
**Procedure for impact test**  
 (See Clause 16.2.3.2 and 16.41.2.)

Series Number	Sample Number											
	1	2	3	1	2	3	1	2	3	1	2	3
1	↓ A	N	N	↓ A	N	N	↓ A	N	N	↓ A	N	N
2	↓ A	N	N	↓ A	N	N	↓ U	↓ A	N	↓ U	↓ A	N
3	↓ A	N	N	↓ U	↓ A	N	↓ A	N		↓ U	↓ A	

NOTES

- (1) Arrows indicate sequence of test procedure.
- (2) A indicates acceptable results from drop.
- (3) U indicates unacceptable results from drop.
- (4) N indicates that no test is necessary.

SA1162E

16.2.3.3 Test results shall be acceptable if the enclosure is capable of complying with all the applicable requirements of this Standard.

16.2.4 Flexing

16.2.4.1 The luminaire shall be supported directly below the pendant support connection points on maximum 25 mm (1 in) wide wooden blocks of sufficient length.

16.2.4.2 A 89 N (20 lb) force shall be applied to a 39 cm<sup>2</sup> (6 in<sup>2</sup>) piece of 19 mm (0.75 in) thick plywood centered on the top of the luminaire midway between the two supports closest to the end.

16.2.4.3 The maximum deflection under load shall be 6.4 mm (0.25 in).

## 16.2.5 Torque and cantilever

### 16.2.5.1 General

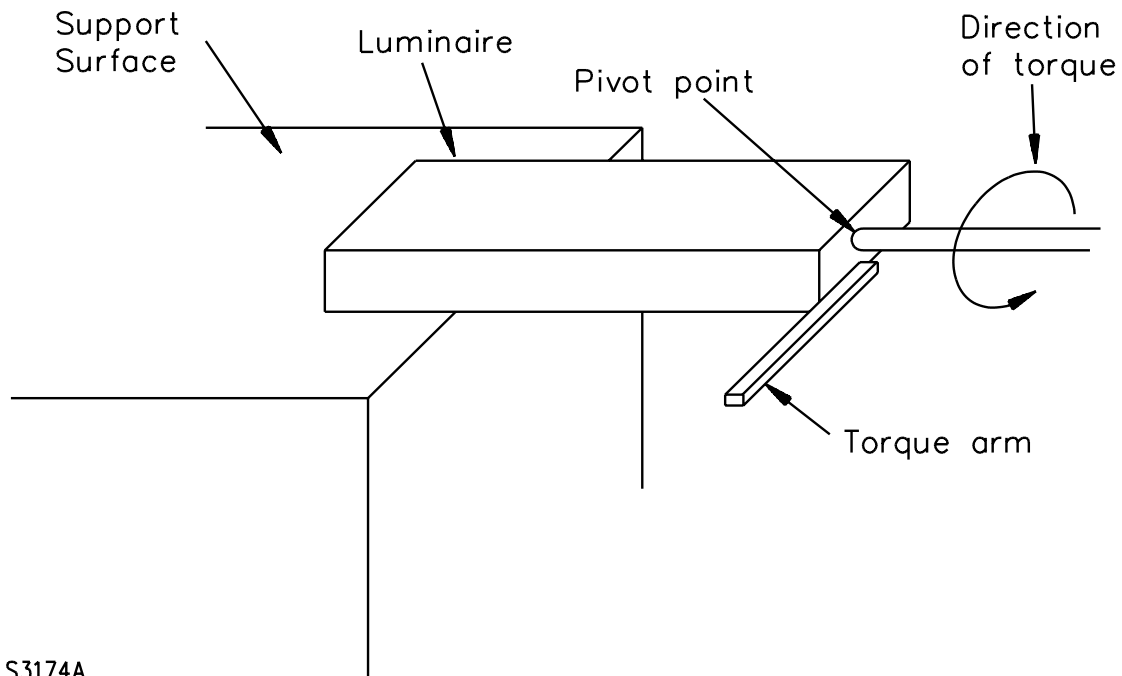
16.2.5.1.1 During the torque and cantilever tests, a comparison shall be made between a control sample luminaire having the minimum metal thickness specified in Table 5.5.1 and a test sample luminaire having reduced metal thickness.

### 16.2.5.2 Torque

16.2.5.2.1 The control and test sample luminaires shall be secured to a solid horizontal surface so that the sample overlaps the surface by a length equal to 10 percent of the sample's overall length. The opposite end of each luminaire shall be supported at the same height as the fixed end by a pivot arm that is attached to the luminaire but allows free rotation of the luminaire around its major axis. A 610 mm (24 in) long torque arm shall be connected to the pivot end of each luminaire at a right angle to its major axis as shown in Figure 16.2.5.2.1.

**Figure 16.2.5.2.1**  
**Torque test**

(See Clause 16.2.5.2.1.)



16.2.5.2.2 A 4.4 N (1 lb) force shall be applied to one end of the arm in a direction that results in luminaire rotation deflection around the major axis.

16.2.5.2.3 During or after the test, the deflection of the test sample luminaire shall be equal to or less than the deflection of the control sample luminaire.

#### 16.2.5.3 Cantilever

16.2.5.3.1 The control and test sample luminaires shall be secured at one end to a solid horizontal surface. The opposite end of each luminaire shall be suspended by the support provided with the luminaire.

16.2.5.3.2 A 11.3 kg (25 lb) weight shall be applied to the suspended end of each luminaire. The weight shall be applied for 1 min.

16.2.5.3.3 During or after the test, the deflection of the test sample luminaire shall be equal to or less than the deflection of the control sample luminaire.

### 16.3 Five-inch flame

16.3.1 Three samples of complete luminaires or enclosure specimens shall be subjected to this test, using the test apparatus of Clause 19.24.

16.3.1 (MEX) In Mexico, Clause 16.3 does not apply.

16.3.2 The conditioning described in Clause 16.3.3 shall be conducted only if:

- (a) the enclosure material exhibits a reduction in flame-resistance properties as a result of long-term thermal aging; or
- (b) the enclosure material thickness is less than the minimum thickness subjected to the long-term thermal aging.

16.3.3 After conditioning for 40 h at  $23 \pm 2$  °C and  $50 \pm 5$  percent relative humidity, the test samples shall be placed in a full-draft air-circulating oven for 7 d at a temperature at least 10 °C above the temperatures measured during the normal temperature test and, in no case, less than 70 °C.

16.3.4 The sample shall be positioned to simulate intended usage, with a layer of surgical cotton located 300 mm (12 in) below the point of test flame application.

16.3.5 The burner shall be placed in a location remote from the sample, in a vertical position, and ignited. The burner shall be adjusted to provide a 125 mm (5 in) overall height flame with a 38 mm (1.5 in) high inner blue cone.

16.3.6 The flame shall be applied at an angle of approximately 20 degrees from the vertical to 3 different locations on each of the 3 samples, in the following areas, as appropriate:

- (a) any interior portion of the enclosure judged as likely to be ignited (by proximity to live arcing parts, coils, and conductors);
- (b) the outside enclosure of encapsulated portions; and
- (c) the outside enclosure, if the flame cannot be applied to the interior.

16.3.7 The flame shall be applied for 5 s and removed for 5 s. This cycle shall be repeated 5 times at each location.

16.3.8 Test results shall be acceptable when the following conditions are met:

(a) the material does not continue to burn more than 1 min after the fifth flame application at any of the locations.

(b) there are no flaming drops or glowing particles that ignite the surgical cotton below the sample.

(c) no visible flame shall be observed on the surface of the enclosure opposite to the surface on which the test flame is applied during the test. In addition, unless otherwise specified in the relevant end-product standard, no opening greater than 3 mm appears after the test has been performed and the sample has cooled for 30 s.

16.3.9 If any one of the 3 samples does not comply, 3 new samples shall comply when the test is repeated in a manner identical to that used for the unsuccessful sample, in order for the test results to be acceptable.

#### **16.4 Mold stress relief**

16.4.1 A sample of the complete thermoplastic enclosure shall be placed in a circulating air oven and maintained at a temperature 10 °C higher than the maximum temperature measured on the surface of the enclosure during the normal temperature test but in no case less than 70 °C, for a period of 7 h.

16.4.2 After the sample has cooled to room temperature, the sample shall comply with the applicable requirements of this Standard.

#### **16.5 Wet locations**

##### **16.5.1 General**

16.5.1.1 A luminaire with an opening for supply connections shall be fitted with the intended supply connection means.

16.5.1.2 A luminaire provided with a receptacle that has an automatic closure cover shall withstand the rain test of Clause 16.5.2 and the sprinkler test of Clause 16.5.3, with the cover closed.

16.5.1.3 A luminaire provided with a receptacle that does not have an automatic closure shall withstand the rain test of Clause 16.5.2 and the sprinkler test of Clause 16.5.3 with the cover open, closed, and with and without an attachment plug in place.

## 16.5.2 Rain

16.5.2.1 A luminaire that is subjected to the rain test shall be conditioned by performing the normal temperature test of Clause 14 or by being operated for at least 30 min.

16.5.2.2 After the conditioning, rings, frames, lamps, and other replaceable parts serving to compress gaskets and bushings shall be removed and then reinstalled.

16.5.2.3 The rain test apparatus shall be in accordance with Clause 19.17.

16.5.2.4 The luminaire shall be installed in accordance with the manufacturer's instructions. The mounting shall simulate the intended mounting method, and only the surfaces exposed to the elements shall be subjected to the rain test.

16.5.2.5 The luminaire shall be positioned in the focal area of the spray heads of the rain test apparatus so that the greatest quantity of water is likely to enter the enclosure of the luminaire.

16.5.2.6 The test shall be conducted in the sequence shown in Table 16.5.2.1.

**Table 16.5.2.1**  
**Rain test operating sequence**

(See Clause 16.5.2.6.)

Test duration, h	Test period, h	Lamp	Water
0 – 1.0	1.0	On	Off
1.0 – 1.5	0.5	Off	On
1.5 – 3.5	2.0	On	On
3.5 – 4.0	0.5	Off	On

16.5.2.7 Immediately after the rain test, the luminaire shall:

- (a) withstand the dielectric voltage-withstand test of Clause 17.1;
- (b) not have permitted water to enter and accumulate in quantities sufficient to interfere with operation of the luminaire or to create a hazard; and
- (c) not have permitted water to contact electrical parts, except lamps or components suitable for the condition.

16.5.2.7 (MEX) In Mexico, immediately after the rain test, the luminaire shall withstand the insulation resistance test of Clause 17.5 (MEX).

### 16.5.3 Sprinkler

16.5.3.1 A luminaire that is subject to the sprinkler test shall be conditioned by performing the normal temperature test of Clause 14 or by being operated for at least 30 min.

16.5.3.2 After the conditioning, rings, frames, lamps, and other replaceable parts of the luminaire serving to compress gaskets and bushings shall be removed and then reinstalled.

16.5.3.3 The sprinkler test apparatus shall be in accordance with Clause 19.18.

16.5.3.4 The luminaire shall be installed in accordance with the manufacturer's instructions. The mounting shall simulate the intended mounting method, and only the surfaces exposed to the elements shall be subjected to the sprinkler test.

16.5.3.5 A ground-mounted surface luminaire shall be turned about its vertical axis to four positions, each 90 degrees from the others. It shall remain in each position for 30 min during the 2 h portion of the test, with the adjustable parts arranged for maximum vulnerability to the water spray.

16.5.3.6 A ceiling-mounted or wall-mounted luminaire shall be installed with the vertical axis of the luminaire 910 mm (36 in) away from the vertical plane of the spray head and positioned with the dimensional center of the luminaire on a line projected from the centerline of the spray head.

16.5.3.7 The test shall be conducted in the sequence shown in Table 16.5.3.1.

**Table 16.5.3.1**  
**Sprinkler test operating sequence**

(See Clause 16.5.3.7.)

Test duration, h	Test period, h	Lamp	Water
0 – 1.0	1.0	On	Off
1.0 – 1.5	0.5	Off	On
1.5 – 3.5	2.0	On	On
3.5 – 4.0	0.5	Off	On

16.5.3.8 Immediately after the sprinkler test, the luminaire shall:

- (a) withstand the dielectric voltage-withstand test of Clause 17.1;
- (b) not have permitted water to enter and accumulate in quantities sufficient to interfere with operation of the luminaire or to create a hazard; and
- (c) not have permitted water to contact electrical parts, except lamps or components suitable for the condition.

#### 16.5.4 Immersion

16.5.4.1 A luminaire shall be subjected to the immersion test in accordance with Table 16.5.4.1, with or without an auxiliary well form, and mounted face-up, with the screws that attach the face torqued to the manufacturer's recommended values.

**Table 16.5.4.1**  
**Immersion test operating sequence**

(See Clause 16.5.4.1.)

Test duration, h	Test period, h	Lamp	Location
0 – 3.5	3.5	On	Dry
3.5 – 7.5	4.0	Off	Submerged
7.5 – 24.0	16.5	Off	Dry
24.0 – 27.5	3.5	On	Dry
27.5 – 31.5	4.0	Off	Submerged
31.5 – 48.0	16.5	Off	Dry
48.0 – 51.5	3.5	On	Dry
51.5 – 55.5	4.0	Off	Submerged

16.5.4.2 The luminaire shall be conditioned by being operated in a dry location at room temperature for 3.5 h.

16.5.4.3 The luminaire shall be de-energized and immediately submerged under at least 300 mm (12 in) of water. The temperature of the water before submersion shall be 5 °C or lower. The luminaire shall remain under water for at least 4 h and then be removed from the water.

16.5.4.4 The procedure of Clauses 16.5.4.2 and 16.5.4.3 shall be conducted three times. Before the second sequence and the third sequence, the luminaire shall be conditioned by placing it in a dry location at room temperature for approximately 16.5 h.

16.5.4.5 Immediately following the third sequence, the luminaire shall be removed from the water and subjected to the dielectric voltage-withstand test of Clause 17.1. There shall be no dielectric breakdown, and no water shall have entered the luminaire.

### 16.5.5 UV exposure conditioning

16.5.5.1 The weatherometer test apparatus shall be in accordance with Clause 19.25.

16.5.5.2 Three test samples of a polymeric water shield or a polymeric material used for the enclosure of electrical equipment that will be exposed to a UV weathering source shall be acceptably resistant to degradation when exposed to:

- (a) 720 h of twin enclosed carbon-arc (ASTM G 151 and G 153); or
- (b) 1000 h of xenon-arc (ASTM G 151 and G 155).

16.5.5.2 (MEX) In Mexico, three test samples of a polymeric water shield or a polymeric material used for the enclosure of electrical equipment that will be exposed to a UV weathering source shall be acceptably resistant to degradation when exposed to:

- (a) 720 h of twin enclosed carbon-arc (NMX-J-553-ANCE); or
- (b) 1000 h of xenon-arc (NMX-J-553-ANCE).

16.5.5.3 Table 16.5.5.1 summarizes the minimum property retention limitations after UV conditioning. The flammability classification of base samples of the material in the thinnest part thickness, and any color under consideration, shall not be reduced as a result of weatherometer conditioning. The average physical property values after UV conditioning shall not be less than 70 percent of the unconditioned value when the standardized small-scale physical tests indicated in Table 16.5.5.1 are performed.

**Table 16.5.5.1**  
**Minimum property retention limitations after ultraviolet light and water immersion conditioning**

(See Clause 16.5.5.3.)

Property	Ultra-violet light*	Water immersion†
Flammability classification	Unchanged	Unchanged
Tensile or flexural strength‡	70 percent	50 percent
Tensile, izod, or charpy impact‡	70 percent	50 percent

\* 720 h twin enclosed carbon-arc or 1000 h xenon-arc exposure.  
† 7 d at 70 °C.  
‡ For functional support, the test methods are tensile strength and flexural strength. For impact resistance the test methods are tensile, izod, or charpy impact.

16.5.5.4 If the impact value for an enclosure material that has been tested in accordance with the requirements of Clause 16.5.5 has exhibited less than 70 percent but at least 25 percent retention of the impact property, it shall be considered acceptable, provided that it fulfills the following requirements:

- (a) the unconditioned equipment shall comply with the resistance-to-impact requirement levels shown in Table 16.5.5.2; and
- (b) the specimens exposed to the 720 h twin enclosed carbon-arc UV conditioning or 1000 h xenon-arc UV conditioning have retained at least 80 percent of the 360 h twin enclosed carbon-arc UV conditioning or 500 h xenon-arc UV conditioning impact level. As an alternative, this UV conditioning may be conducted for a longer period of time in 360 h increments carbon-arc or 500 h increments for xenon-arc, provided that the final exposure impact level is not less than 80 percent of the previous increment's impact level.

**Table 16.5.5.2**  
**Unconditioned ball-impact requirements for equipment exposed to UV radiation\***

(See Clause 16.5.5.4.)

Retention of property after UV conditioning, percent†	Impact level for ball-impact test on unconditioned specimens, J (ft-lb)
70 or more	6.8 (5.0)
50 – 69	13.6 (10.0)
25 – 49	27.2 (20.0)
Less than 25	Not acceptable

\*For other than easily moved hand-held and counter-supported equipment.  
 †720 h twin enclosed carbon-arc exposure or 1000 h xenon-arc exposure or after the final exposure if longer exposures are conducted.

16.5.6 Polymeric thermal conditioning

16.5.6.1 A polymeric water shield shall be conditioned in a circulating oven for 168 h at a temperature in accordance with Table 16.5.6.1 and as determined by the normal temperature test of Clause 14. The conditioning time may be reduced by 1/2 for each increase in oven temperature of 10 °C. If the sample is too large for the test oven, the sample may be cut to fit.

**Table 16.5.6.1**  
**Thermal conditioning exposure temperature**

(See Clause 16.5.6.1.)

Normal test temperature, °C	Oven test temperature, °C
65 – 75	85
76 – 85	95
86 – 95	105

16.5.6.2 The water shield shall have no obvious deterioration or deformation after conditioning.

16.5.7 Impact conditioning

16.5.7.1 A sample of the water shield shall be mounted on the luminaire for impact conditioning. The sample shall be subjected to a 4.1 J (3 ft-lb) impact from the steel sphere of Clause 19.21 from a vertical distance of 775 mm (30.5 in) on any surface of the water shield that is exposed and that can be subjected to an impact during its intended use.

16.5.7.2 The horizontal or top surface of the water shield shall be subjected to an impact from the steel sphere shown in Figure 19.21.1. Other surfaces of the water shield shall be subjected to an impact from the steel sphere suspended by a cord, as shown in Figure 19.21.2.

#### 16.5.8 Luminaire gasket assembly accelerated aging

16.5.8.1 A luminaire with gaskets and bushings in place shall be subjected to the luminaire gasket assembly accelerated aging test.

16.5.8.2 The luminaire gasket assembly shall be conditioned in a circulating air oven for 240 h at 20 °C above the maximum gasket or bushing temperature as determined by the normal temperature test in Clause 14.

16.5.8.3 After the conditioning, any part of the luminaire that affects the sealing of the gasket assembly shall be opened. There shall be no evidence of damage to the gasket assembly, and the gasket shall remain in place. The luminaire gasket assembly shall be closed and the luminaire shall fulfill the criteria of the following tests, as applicable:

- (a) the rain test of Clause 16.5.2;
- (b) the sprinkler test of Clause 16.5.3; and
- (c) the immersion test of Clause 16.5.4.

#### 16.5.9 Gasket accelerated aging (Method A)

16.5.9.1 A gasket or bushing shall be subjected to the gasket accelerated aging test.

16.5.9.2 Three specimens of the gasket or bushing material shall be evaluated for tensile strength and elongation, and the average values calculated.

16.5.9.3 Three additional specimens shall be conditioned for 168 h in a circulating air oven at a temperature 20 °C above the maximum gasket or bushing temperature as determined by the normal temperature test of Clause 14.

16.5.9.4 After conditioning, the 3 specimens shall have an average tensile strength of not less than 60 percent and an average elongation of not less than 75 percent of the values determined before conditioning.

#### 16.5.10 Gasket accelerated aging (Method B)

16.5.10.1 The test apparatus shall be in accordance with Clause 19.26.

16.5.10.2 Three specimens of the gasket or bushing material shall be measured to determine the average thickness.

16.5.10.3 The test weight shall be placed on the middle portion of each specimen for a period of 2 h. At the end of that time, the weight shall be removed and the specimen shall be allowed to rest at room temperature for 30 min. The average thickness of the compressed portion of the 3 specimens shall be more than 50 percent of the initial thickness.

16.5.10.4 The specimens shall be conditioned for 168 h in a circulating air oven at a temperature 20 °C above the maximum gasket or bushing temperature as determined by the normal temperature test of Clause 14.

16.5.10.5 The procedure of Clauses 16.5.10.2 and 16.5.10.3 shall be repeated on the specimens approximately 24 h after removal from the oven. The average thickness of the compressed portion of the specimens shall be more than 50 percent of the initial thickness.

#### 16.5.11 Gasket adhesion

16.5.11.1 A gasket assembly secured by an adhesive shall be subjected to the gasket adhesion test.

16.5.11.2 Three gasket assemblies shall be used to determine the average initial force required to remove the gasket from its mounting surface. The force shall be applied to the edge of the gasket in a plane perpendicular to the surface on which the gasket is mounted.

16.5.11.3 Six additional gasket assemblies shall be conditioned as described in Clause 16.5.10.4. The force required to remove the gaskets from the mounting surface of three samples shall be measured within 30 min after the conditioning. The force required to remove the gaskets from the mounting surface of the three remaining samples shall be measured 24 h after the conditioning.

16.5.11.4 After conditioning, the average force necessary to remove the gaskets from the mounting surface shall be not less than 60 percent of the initial average value measured before conditioning.

#### 16.5.12 Paint adhesion

16.5.12.1 A painted enclosure or representative part shall be subjected to the tests of Clauses 16.5.12.2 and 16.5.12.3.

16.5.12.1 (MEX) In Mexico, a paint enclosure or representative part shall be subjected to the tests of Clauses 16.5.12.2 (MEX) and 16.5.12.3 (MEX).

16.5.12.2 An area of approximately 625 mm<sup>2</sup> (1 in<sup>2</sup>) shall be cross-cut with a sharp knife. The cuts in the same direction shall be parallel and spaced 1 to 2 mm (0.40 to 0.80 in) apart. Cellulose adhesive tape shall be firmly applied to the cross-cut surface, and upon removal of the tape, not more than 15 percent of the paint shall be removed from the test sample.

16.5.12.2 (MEX) In Mexico, the painted surface of the housing shall be scraped all the way down, using a 6-blade cutting tool that has a 1 mm (0.04 in) space between each blade, leaving a grid of squares 5 mm x 5 mm (0.20 × 0.20 in). A hard bristle brush shall be rubbed lightly and diagonally over the squares, 5 times in one direction and 5 times in the opposite direction.

16.5.12.3 When a sharp knife is scraped across the painted surface, the paint may have a tendency to curl, but shall not flake, crumble, or give evidence of lack of adhesion.

16.5.12.3 (MEX) In Mexico, if more than 5 percent of the paint comes off at the intersecting points on the grid, the paint adhesion shall not be acceptable.

#### 16.6 Hot-wire ignition (HWI)

16.6.1 Five samples of a polymeric enclosure material shall be subjected to the hot-wire ignition test described in UL 746C and Clause 4.3.1 of CSA C22.2 No. 0.17.

16.6.1 (MEX) In Mexico, five samples of a polymeric enclosure material shall be subjected to the hot-wire ignition test described in NMX-J-565/6-ANCE.

16.6.2 The average time to ignition shall be not less than 15 s.

#### 16.7 Glow-wire end product

16.7.1 The test apparatus shall be in accordance with Clause 19.28 and IEC 60695-2-11.

16.7.1 (MEX) In Mexico, the test apparatus shall be in accordance with NMX-J-565/2-11-ANCE.

16.7.2 Components can, under fault conditions or overload conditions, attain a temperature that ignites or affects the enclosure or electrical parts in their vicinity. The glow-wire test simulates thermal stresses that can be produced by sources of heat or ignition, for short periods, in order to evaluate the risk of fire.

16.7.3 Test specimens less than 0.25 mm (0.010 in) or more than 6.4 mm (0.25 in) thick shall not be acceptable for this test method.

16.7.4 The test specimen shall be a complete subassembly or component. If it is necessary to cut off a suitable part to perform the test, the test conditions shall not be significantly different from the conditions of normal use with regard to shape, ventilation, effect of thermal stress, and the possibility of flames, burning, or glowing particles falling in the vicinity of the specimen.

16.7.5 Three test specimens shall be conditioned at a temperature of  $23 \pm 2$  °C and a relative humidity of 50 percent for a period of 40 h prior to the glow-wire test. The glow-wire test shall be conducted at an ambient temperature of  $25 \pm 5$  °C.

16.7.6 The specimen shall be fixed to the positioning clamp of the glow-wire test apparatus shown in Figure 19.28.1, so that heat losses due to the supporting means are insignificant. The tip of the glow-wire shall be applied to the part of the surface of the specimen that is likely to be subjected to thermal stresses in normal use. In cases where the areas subjected to the thermal stress during normal use are not specified in detail, the tip of the glow-wire shall be applied at the location where the section is thinnest, but it shall not be applied less than 15 mm (0.6 in) from the upper edge of the specimen. If possible, the tip of the glow-wire shall be applied to flat surfaces and not to grooves, knockouts, narrow recesses, or sharp edges.

16.7.7 Before each test, the tip of the glow-wire shall be cleaned of any residue from previous tests.

16.7.8 The tip of the glow-wire shall be electrically heated to the temperature specified in Table 16.7.1, as measured by the calibrated thermocouple, for the conditions involved. Before the test is started, the temperature and the heating current shall be constant for a period of at least 60 s. During this period of 60 s and during calibration, adequate screening shall be provided to ensure that heat radiation does not influence the specimen.

**Table 16.7.1**  
**Glow-wire test temperatures**

(See Clause 16.7.8.)

Temperature	Parts of insulating material in contact with current-carrying parts or retaining them in position	Parts of insulating material for enclosures and covers not retaining current-carrying parts in position
$550 \pm 10$ °C	To ensure a minimum level of ignition of parts likely to contribute to a risk of fire	To ensure a minimum level of ignition of parts likely to contribute to a risk of fire
$650 \pm 10$ °C	Equipment for attended use	Fixed accessories in installations
$750 \pm 10$ °C	Equipment for attended use under more stringent conditions. Fixed accessories in installations	Equipment for attended use under more stringent conditions. Equipment intended for use near the supply point of a building
$850 \pm 10$ °C	Equipment for unattended use, continuously loaded	Equipment for unattended use, continuously loaded
$950 \pm 10$ °C	Equipment for unattended use, continuously loaded under more stringent conditions. Equipment intended for use near the supply point of the building	Equipment for unattended use, continuously loaded under more stringent conditions

16.7.9 The tip of the glow-wire shall then to be brought into contact with the test specimen for  $30 \pm 1$  s. The heating current shall be maintained during this period. After this period, the glow-wire and specimen shall be slowly separated, avoiding any further heating of the specimen and any movement of air that can affect the result of the test. The penetration of the tip of the glow-wire into the specimen shall be mechanically limited to 7 mm (0.275 in).

16.7.10 During the application of the glow-wire and during the test period of 30 s, the specimen, the parts surrounding the specimen, and the layer of tissue paper and the pine board placed below shall be observed, and the following noted:

- (a) the time from application of the tip until the specimen or layer below ignites;
- (b) the time from application of the tip until flame extinguishes during or after removal; and
- (c) the maximum height of any flame, vertically from the upper edge of the glow-wire and the visible tip of the flame, if the flame is visible on the specimen for more than 5 s. The initial high flame that can appear for approximately 1 s shall be disregarded.

16.7.11 Test results shall be acceptable if:

- (a) there is no flame and no glowing; or
- (b) flames extinguish within 30 s after removal of the glow-wire tip, and there is no ignition of the tissue paper or scorching of the pinewood board.

## **16.8 High-current arc ignition (HAI)**

16.8.1 Three samples of a polymeric enclosure material shall be subjected to the high-current arc ignition test described in UL 746C and CSA C22.2 No. 0.17.

16.8.1 (MEX) In Mexico, three samples of a polymeric enclosure material shall be subjected to the high-current arc ignition test described in NMX-J-565/7-ANCE.

16.8.2 The average number of arcs to result in ignition for the 3 samples tested shall not be less than 15.

## **16.9 End-product arc resistance**

16.9.1 The test current shall be based upon the maximum normal operating current. The voltage used for the test shall be equal to the available voltage at the live part. The arc shall be established between the live part and any adjacent part where breakdown is likely to occur. The arc shall be used to ignite materials forming parts of the enclosure or to ignite materials located between the parts of different potential. The arc shall be established by means of a copper or stainless steel conductive probe. The conductive probe shall be used to create arc tracking or a carbon buildup across the surface of the insulating material at a minimum rate of 30 arc separations per min. There shall be no ignition of the insulating material.

## 16.10 Polymeric support

16.10.1 A polymeric part shall support for 1 minute, without distortion, four times the weight of a part it is relied upon to suspend in its intended application.

16.10.2 The test shall be performed in an oven maintained at a temperature 10 °C higher than the maximum normal operating temperature of the polymeric part measured during the normal temperature test of Clause 14.

16.10.3 A polymeric part shall be installed as intended, with the weight evenly distributed.

## 16.11 Metallized polymeric parts coating adhesion

16.11.1 A metallized polymeric part that employs an electrically conductive material shall comply with the applicable requirements of UL 746C with respect to the adhesive properties of the material.

16.11.1 (MEX) In Mexico, Clause 16.11 does not apply.

## 16.12 Flaming oil

16.12.1 A sample of the complete finished bottom of the fire enclosure shall be securely supported in a horizontal position. Bleached cheesecloth of approximately 40 g/m<sup>2</sup> shall be placed in one layer over a shallow, flat-bottomed pan approximately 50 mm below the sample. The pan shall be of sufficient size to cover completely the pattern of openings in the sample, but not large enough to catch any of the oil that runs over the edge of the sample or otherwise does not pass through the openings.

**NOTE Use of a metal screen or a wired-glass enclosure surrounding the test area is recommended.**

16.12.1 (MEX) In Mexico, Clause 16.12 does not apply.

16.12.2 A small metal ladle (preferably no more than 65 mm in diameter), with a pouring lip and a long handle whose longitudinal axis remains horizontal during pouring, shall be partially filled with 10 ml of a distillate fuel oil that is a medium volatile distillate having a mass per unit volume between 0.845/ml and 0.865/ml, a flash point between 43.5 °C and 93.5 °C, and an average calorific value of 38 MJ/l. The ladle containing the oil shall be heated and the oil ignited and permitted to burn for 1 min, at which time all the hot flaming oil is poured at the rate of approximately 1 ml/s in a steady stream onto the center of the pattern of openings, from a position approximately 100 mm above the openings.

16.12.3 The test shall be repeated twice at 5 min intervals, using clean cheesecloth.

16.12.4 During these tests, the cheesecloth shall not ignite.

### 16.13 Conduit knockout and twistout

16.13.1 The following test shall apply only to conduit entries and shall be performed on a sample securely held in place using the test apparatus described in Clause 19.23.

16.13.2 A force of 44 N (10 lb) shall be applied to a knockout for 1 min by means of a 6.4 mm (0.250 in) diameter mandrel with a flat end. The force shall be applied to the exterior surface of the knockout, in a direction perpendicular to the plane of the knockout, and at the point most likely to result in movement.

16.13.3 The knockout shall remain in place, and the clearance between the knockout and the opening shall be no more than 1.6 mm (0.063 in) when measured after the force has been removed.

### 16.14 Self-threading screw torque

16.14.1 Self-threading or sheet metal screws may be used if threads are not stripped when the screw is tightened with a torque of 3.39 N·m (30 lb-in) and if the part or the assembly supported by the screw withstands for 1 min a force equal to four times the mass of the part or assembly, applied in a direction coincident with the axis of the screw.

16.14.1 (MEX) Screws may be used if threads are not stripped when the screw is tightened with the torque given in Table 16.14.1 (MEX) and if the part or the assembly supported by the screw withstands for 1 min a force equal to four times the mass of the part or assembly, applied in a direction coincident with the axis of the screw.

**Table 16.14.1 (MEX)**  
**Screw torque**

(See Clause 16.14.1 (MEX).)

Nominal screw diameter, mm	Torque, N·m	
	Headless screws	Other screws and nuts
Up to and including 2.8	0.20	0.4
Greater than 2.8, up to and including 3.0	0.25	0.5
Greater than 3.0, up to and including 3.2	0.30	0.6
Greater than 3.2, up to and including 3.6	0.40	0.8
Greater than 3.6, up to and including 4.1	0.70	1.2
Greater than 4.1, up to and including 4.7	0.80	1.8
Greater than 4.7, up to and including 5.3	0.80	2.0
Greater than 5.3, up to and including 6.0	—	2.5
Greater than 6.0	—	8.0

## 16.15 Loading

16.15.1 A supporting device shall support a load equal to four times the total mass to be supported under intended operating conditions for 1 h. The load shall be applied in the direction of actual loading conditions.

16.15.2 Where more than one support is provided, the load shall be distributed as follows:

(a) where the parts supported are no more than 11.3 kg (25 lb), the full load shall be applied to each support; or

(b) where the parts supported are more than 11.3 kg (25 lb), the distribution of the load shall be similar to that encountered in the field.

16.15.3 There shall be no deflection or deformation either during or after loading that reduces electrical spacings or compromises safety.

## 16.16 Snap-in or tab-mounted parts pull test without conduit opening

16.16.1 A snap-in or tab-mounted part not provided with a knockout or conduit opening and not secured by at least one screw or rivet shall be assembled in accordance with the manufacturer's assembly instructions and subjected to the test of Clause 16.16.2.

16.16.2 An evenly distributed 44.5 N (10 lb) force shall be applied for 1 minute in the direction most likely to dislodge the part being tested.

16.16.3 Before and after the test of Clause 16.16.2, the luminaire shall comply with the bonding circuit impedance test of Clause 17.2.

16.16.4 The part shall remain attached to the luminaire, and permanent deformation of the luminaire or its parts shall not exceed 3.2 mm (0.125 in).

## 16.17 Snap-in or tab-mounted parts pull test with conduit opening

16.17.1 A snap-in or tab-mounted part of a luminaire provided with a knockout or conduit opening that is not additionally secured by at least one screw or rivet shall be tested as follows:

(a) a length of rigid conduit shall be connected to the opening in the part to be tested. The total length of exposed conduit shall be 305 mm (12 in). The part shall be mounted to the luminaire as intended.

(b) a 133 N (30 lb) force shall be applied for 1 min at the end of the conduit in a direction perpendicular to the plane of the part being tested.

(c) a 45 N (10 lb) force shall be applied for 1 min at the end of the conduit in a direction parallel to the plane of the part being tested and in the direction most likely to dislodge the part.

16.17.2 The part shall remain attached to the luminaire and shall comply with the bonding circuit impedance test of Clause 17.2.

16.17.3 If the part being tested is provided with more than one conduit opening, the test shall be repeated for each opening, using a new sample for each test.

#### **16.18 Suspended-ceiling luminaires – security of clips**

16.18.1 A luminaire provided with integral suspended ceiling clips shall be mounted as intended to a representative ceiling grid.

16.18.2 The ceiling grid shall be inverted so that the total weight of the luminaire is applied normal to the luminaire mounting plane for a period of 1 min.

16.18.3 The luminaire shall remain attached to the ceiling grid by the mounting clips.

#### **16.19 Movable joint rotation**

16.19.1 A movable joint shall be capable of withstanding 6000 cycles of motion, linear or rotational, without damage to the jacket or the insulation of the conductors. One cycle shall consist of moving the part to the maximum extent possible in one direction and back again, then to the maximum extent possible in the opposite direction.

#### **16.20 Movable joint torsion and pull**

16.20.1 A movable joint shall withstand the following for 1 min:

- (a) a torsion of  $2.26 \pm 0.056$  N·m ( $20 \pm 0.5$  lb·in); and
- (b) a straight pull applied by a mass of 16 kg (35 lb) or four times the maximum weight recommended by the manufacturer, whichever is greater.

#### **16.21 Strain relief**

16.21.1 Strain relief for flexible cords

16.21.1.1 A pull force of 156 N (35 lb) shall be applied for 1 min to the flexible cord in a direction perpendicular to the plane of the entrance into the luminaire.

16.21.1.2 Test results shall be acceptable if there is no:

- (a) movement of the flexible cord of more than 1.6 mm (0.063 in); and
- (b) breaking of the conductor or loosening of the wiring connections inside the enclosure of the luminaire.

### 16.21.2 Strain relief for conductors

16.21.2.1 A pull force of 89 N (20 lb) shall be applied for 1 min to the conductor in a direction perpendicular to the plane of the entrance to the conductor connection.

16.21.2.2 There shall be no breaking of the conductor or loosening of the conductor connections.

### 16.22 Tempered glass impact

16.22.1 A test specimen of tempered glass shall be broken by impact to determine the acceptability of the temper of the glass.

16.22.2 The test shall be conducted at  $25 \pm 5$  °C.

16.22.3 The specimen shall be weighed, and the weight of  $65 \text{ cm}^2$  ( $10 \text{ in}^2$ ) shall be calculated.

16.22.4 The lower surface of the tempered glass specimen shall be covered with adhesive tape to retain the particles when the specimen breaks.

16.22.5 The glass shall be placed on a flat surface and shattered with a center punch at a point 30 mm (1.18 in) from the midpoint on the edge of the glass toward the center. The edge shall be defined as the longest dimension on an irregular shape. When shattered, the glass shall completely dice into particles.

16.22.6 The 10 largest crack-free particles shall be weighed together within 5 min, to avoid further fracture. The total weight shall be less than the calculated weight of  $65 \text{ cm}^2$  ( $10 \text{ in}^2$ ) of the original specimen.

### 16.23 Glass support adhesive

16.23.1 One sample assembly of the glassware and the adhesive material used as the sole support shall be conditioned at  $23 \pm 2$  °C and a relative humidity of  $50 \pm 5$  percent for 48 h.

16.23.2 The sample shall be conditioned in an air-circulating oven at the temperature and for the time specified by Table 16.23.1.

16.23.3 After conditioning, the sample shall be removed from the oven and allowed to cool to room temperature. The sample shall be supported in the intended manner, shall be oriented so the adhesive supports the glass, and shall comply with the glass support test of Clause 16.24.

**Table 16.23.1**  
**Glass adhesive conditioning oven temperature and time**

(See Clause 16.23.2.)

Adhesive rating, °C	Oven temperature, °C			
	300 h (12.5 d)	720 h (30 d)	1000 h (42 d)	1440 h (60 d)
60	125	115	110	100
75	145	135	125	110
90	160	150	140	130
105	180	170	160	145
130	200	190	180	170
155	220	215	205	195
180	245	235	230	220
200	280	265	255	245
220	295	285	275	265
240	N/A	300	290	280

#### 16.24 Glass supported by friction or adhesive

16.24.1 A sample of each luminaire style employing a glass diffuser that is supported by friction or adhesive shall be tested as follows:

- (a) the diffuser shall be weighed.
- (b) an amount of granular material, such as sand, equal to four times the weight of the diffuser shall be poured into the diffuser and distributed it evenly.
- (c) the diffuser shall be mounted as intended.

16.24.2 The diffuser shall stay in place for 1 min.

#### 16.25 Horizontal burning flame

16.25.1 The test apparatus shall be in accordance with Clause 19.29.

16.25.2 Three test bar specimens  $125 \pm 5$  mm ( $5.0 \pm 0.2$  in) in length and  $13 \pm 0.5$  mm ( $0.50 \pm 0.02$  in) in width, with a thickness not exceeding the minimum thickness of the polymeric part being evaluated, or 3 samples of the same size cut from the enclosure, shall be tested. The maximum thickness shall not exceed 13 mm (0.50 in), the edges of the specimens shall be smooth, and the radius on the corners shall not exceed 1.3 mm (0.05 in).

16.25.3 The specimens shall be conditioned for at least 48 h at  $23 \pm 2$  °C and at a relative humidity of  $50 \pm 5$  percent prior to testing.

16.25.4 The test shall be conducted in a draft-free atmosphere in a test chamber with a minimum volume of 1 m<sup>3</sup> (35 ft<sup>3</sup>). There shall be an adequate supply of air.

16.25.5 Each specimen shall be marked by scribing two lines, 25 mm (1 in) and 100 mm (4 in) from one end of the specimen, for a span of 75 mm (3 in).

16.25.6 The specimen shall be supported at the end nearest the 100 mm (4 in) mark, in a support, with its longitudinal axis horizontal and its transverse axis inclined at 45 degrees to the horizontal.

16.25.7 A screen of wire gauze approximately 125 × 125 mm (5 × 5 in) shall be supported in a horizontal position 10 mm (0.4 in) below the edge of the specimen, with the free end of the specimen even with the edge of the gauze, in accordance with Figure 19.29.1.

16.25.8 The gas supply and the air ports of the burner shall be adjusted until a 20 mm (0.79 in) long blue flame is produced.

16.25.9 The burner shall be placed so that the burner flame contacts the end of the specimen as shown in Figure 19.29.1. The free end shall be exposed to the burner flame for 30 s.

16.25.10 If the specimen warps, melts, or shrinks away from the burner flame, the flame shall be moved to keep it in contact with the specimen. Excessive distortion of the specimen during the test can invalidate the results.

16.25.11 The burner shall be removed after 30 s or when the flame front reaches the 25 mm (1 in) mark, whichever comes first, and placed at least 450 mm (18 in) from the specimen.

16.25.12 Materials rated as HB shall:

- (a) not have a burning rate exceeding 40 mm/min (1.57 in/min) over a 75 mm (3 in) span for specimens having a thickness of 3.0 mm (0.12 in) to 13 mm (0.50 in);
- (b) not have a burning rate exceeding 75 mm/min (3 in/min) over a 75 mm (3 in) span for specimens having a thickness less than 3.0 mm (0.12 in); or
- (c) cease to burn before the flame reaches the 100 mm (4 in) reference mark.

16.25.13 If only 1 specimen from a set of 3 specimens does not comply with the requirements, another set of 3 specimens shall be tested. All specimens from this second set shall comply with the requirements in order for material in that thickness to be classified as HB.

## 16.26 Vertical burning flame

16.26.1 The vertical flame test apparatus shall be in accordance with Clause 19.30.

16.26.1 (MEX) In Mexico, Clause 16.26 does not apply.

16.26.2 Five test bar specimens  $125 \pm 5$  mm ( $5.0 \pm 0.02$  in) in length and  $13 \pm 0.5$  mm ( $0.50 \pm 0.02$  in) in width with a thickness not exceeding the minimum thickness of the polymeric part being evaluated, or 5 samples of the same size cut from the enclosure, or 5 samples of the complete enclosure shall be tested. The maximum thickness shall not exceed 13 mm (0.50 in), the edges of the specimens shall be smooth, and the radius on the corners shall not exceed 1.3 mm (0.05 in).

16.26.3 The specimens shall be conditioned for at least 48 h at a temperature of  $23 \pm 2$  °C and a relative humidity of  $50 \pm 5$  percent prior to testing.

16.26.4 The test shall be conducted in a draft-free atmosphere in a test chamber with a minimum volume of 1 m<sup>3</sup> (35 ft<sup>3</sup>). There shall be an adequate supply of air.

16.26.5 Each specimen shall be supported from the upper 6 mm (0.25 in), with the longitudinal axis vertical, by the clamp of a ring stand so that the lower end of the specimen is 9.5 mm (0.37 in) above the top of the burner tube and 300 mm (12 in) above a horizontal layer of 6 mm (0.25 in) thick, free-standing, dry, absorbent surgical cotton approximately 50 × 50 mm (2 × 2 in), as shown in Figure 19.30.1.

16.26.6 The burner shall be adjusted to produce a blue flame 19 mm (0.75 in) high in the vertical position.

16.26.7 The test flame shall be placed centrally under the lower end of the test specimen with the burner tube 9.5 mm (0.37 in) below the specimen. The flame shall be applied to the specimen for 10 s and then removed at least 150 mm (6 in) away from the specimen. The duration of flaming shall be recorded.

16.26.8 When flaming of the specimen ceases, the burner flame shall be immediately placed under the specimen for an additional 10 s flame impingement time. The flame shall then be withdrawn again. The duration of flaming time and glow time of the specimen shall be recorded.

16.26.9 If the specimen drips molten or flaming material during either flame application, the burner shall be tilted to an angle of up to 45 degrees and withdrawn slightly from one of the sides of the specimen during the flaming application, to avoid dripping into the tube of the burner.

16.26.10 The arithmetic mean of the burning times recorded shall be calculated for each specimen.

16.26.11 Materials shall be rated as V-0, V-1, or V-2 on the basis of test results obtained on small bar specimens tested.

16.26.12 If any 1 specimen from a set of 5 specimens does not comply with the requirements, another set of 5 specimens shall be tested. The additional set of 5 specimens shall be tested if the total number of seconds is in the range of 51 to 55 s for V-0 and 251 to 255 s for either V-1 or V-2. All specimens from this second set shall comply with the appropriate requirements in order for the material in that thickness to be rated as V-0, V-1, or V-2.

16.26.13 Materials rated as V-0 shall not have:

- (a) any specimens that burn with flaming combustion for more than 10 s after either application of the test flame;
- (b) a total flaming combustion time exceeding 50 s for the 10 flame applications for each set of 5 specimens;
- (c) any specimens that burn with flaming or glowing combustion up to the holding clamp;
- (d) any specimens that drip flaming particles that ignite the surgical cotton located 300 mm (12 in) below the test specimen; and
- (e) any specimens with glowing combustion that persists beyond 30 s after the second removal of the test flame.

16.26.14 Materials rated as V-1 shall not have:

- (a) any specimens that burn with flaming combustion for more than 30 s after each application of the test flame;
- (b) a total flaming combustion time exceeding 250 s for the 10 flame applications for each set of 5 specimens;
- (c) any specimens that burn with flaming or glowing combustion up to the holding clamp;
- (d) any specimens that drip flaming particles that ignite the surgical cotton located 300 mm (12 in) below the test specimen; and
- (e) any specimens with glowing combustion that persists beyond 60 s after the second removal of the test flame.

16.26.15 For materials rated as V-2, the requirements of Clause 16.26.14 shall apply, except that specimens of materials shall be permitted to drip flaming particles that ignite the surgical cotton.

## 16.27 Needle flame

16.27.1 The test apparatus shall be in accordance with Clause 19.31.

16.27.2 Three samples of the enclosure or component of a luminaire shall be subjected to the test.

16.27.3 The test specimens shall be conditioned for 24 h at a temperature of  $23 \pm 2$  °C and a relative humidity of  $50 \pm 5$  percent.

16.27.4 The test shall be conducted in a draft-free atmosphere in a test chamber with a minimum volume of 1 m<sup>3</sup> (35 ft<sup>3</sup>). There shall be an adequate supply of air.

16.27.5 The specimen shall be arranged in its most unfavourable position of normal use. The means to support the specimen shall not influence the effect of the burner flame or the propagation of flames.

16.27.6 The burner flame shall be adjusted to an overall height of 11 to 13 mm (0.43 to 0.50 in) in the vertical position, and kept at least 150 mm (6 in) away from the specimen to prevent the influence of heat or radiation on the specimen, except when the flame is being applied.

16.27.7 The burner flame shall be applied to part of the inside surface of the specimen that is likely to be affected by flames resulting from normal use or from fault conditions, or from any source of accidental ignition.

16.27.8 The tube of the burner shall be oriented to allow application of the flame in the most unfavourable location. When the burner flame has been positioned so that the tip of the flame is in contact with the surface of the specimen, the burner shall not be moved.

16.27.9 The burner shall be tilted to an angle of 45 degrees from the horizontal, and the end of the burner tube shall be positioned 8 mm (0.32 in) below the specimen and 5 mm (0.20 in) from the specimen, as shown in Figure 19.31.1.

16.27.10 The burner flame shall be applied to the specimen for 30 s and removed for 60 s and then reapplied to the same location for 30 s.

16.27.11 The burner flame may be applied to the outside surface of the specimen if the electrical components that are enclosed by the specimen are of the encapsulated type or of such a size that the flame cannot be applied inside.

16.27.12 The burner flame may be applied to more than one point on the same specimen as long as the previous tests do not affect the result of the test.

16.27.13 During the test, the specimen and the parts surrounding the specimen shall be observed. In the case of ignition of the specimen or of the parts surrounding it, the duration of burning shall be measured. Duration of burning shall be the time interval from the moment the test flame is removed until the flames have extinguished or the glowing of the specimen is no longer visible.

16.27.14 Test results shall be acceptable if:

- (a) the specimen does not ignite;
- (b) flames, burning particles, or glowing particles falling from the specimen do not spread fire to the surrounding parts, and there is no flame or glowing of the specimen at the end of application of the test flame; or
- (c) the duration of burning is less than 60 s after each application.

16.27.15 A specimen having an HB flammability rating as specified in Clause 16.25 shall be considered to have the equivalent of a V-2 rating if it complies with the test of Clauses 16.27.1 to 16.27.14.

**16.28 Lamp containment barrier thermal shock**

16.28.1 Three test samples of the glass containment barrier specified in Clause 9.3 shall be subjected to the test at a room temperature of  $25 \pm 5$  °C.

16.28.2 Three tubular quartz arc tube test segments shall be chosen, based on the size and weight shown in Table 16.28.1. The length shall be adjusted to comply with the required segment weight.

16.28.3 Each arc tube segment shall be removed from the oven and, within 2 s, placed on the thinnest part of each lamp containment barrier, with the longitudinal axis of the cylinder perpendicular to the plane of the barrier.

16.28.4 The test sample shall be supported on its outer edges and oriented as it would be with the luminaire installed in accordance with its installation instructions.

16.28.5 Three quartz arc tube segments shall be chosen in accordance with Table 16.28.1 and shall be preheated in an oven to 1100 °C for at least 15 minutes. The length of arc tube segment shall be adjusted to maintain the indicated weight.

16.28.6 The test sample shall not shatter or crack.

**Table 16.28.1**  
**Quartz arc tube test segments**  
 (See Clauses 16.28.2, 16.28.5, and 16.29.2.)

Lamp wattage	Outside diameter		Wall thickness		Weight	
	mm	(in)	mm	(in)	g	(oz)
150 or less	13.3 – 14.7	(0.524 – 0.579)	0.95 – 1.05	(0.037 – 0.041)	0.57 – 0.63	(0.020 – 0.022)
151 to 400	20.5 – 22.7	(0.807 – 0.894)	1.18 – 1.27	(0.046 – 0.050)	1.05 – 1.16	(0.037 – 0.041)
>400	24.5 – 27.1	(0.965 – 1.067)	1.80 – 2.00	(0.071 – 0.079)	3.80 – 4.20	(0.134 – 0.142)

### 16.29 Polymeric lamp containment barrier melt-through

16.29.1 Three test samples of the polymeric containment barrier shall be subjected to the test. Each test sample shall:

- (a) be rectangular and have a minimum dimension of 150 mm (6 in) on each side;
- (b) be supported on its outer edges, 300 mm (12 in) above a surface covered by a layer of dry absorbent cotton of a nominal 6 mm (0.25 in) thickness;
- (c) be oriented as it would be with the luminaire installed in accordance with its installation instructions; and
- (d) be preheated to and maintained at the maximum barrier operating temperature recorded during the normal temperature test.

16.29.2 Three quartz arc tube segments shall be chosen in accordance with Table 16.28.1 and shall be preheated in an oven to 1100 °C for at least 15 min. Each arc tube segment shall then be removed from the oven and, within 2 s, placed on the thinnest part of each lamp containment barrier, where particles from a ruptured lamp arc tube are likely to drop and rest, with the longitudinal axis of the cylinder perpendicular to the plane of the barrier.

16.29.3 The cotton indicator located below the barrier sample shall not be ignited as result of this test.

### 16.30 Polymeric connector loading

16.30.1 A two-piece polymeric connector shall support a 90.7 kg (200 lb) weight attached to it for 1 min when secured to an outlet box mounted in an oven adjusted to operate at 100 °C.

16.30.2 Test results shall be acceptable if there is no distortion of the connector.

### 16.31 Junction box rigidity

16.31.1 A junction box intended for pulling conductors shall be tested as follows:

- (a) the luminaire shall be secured on a 12.7 mm (0.5 in) thick wood panel so that it is rigidly affixed to the panel, and the panel shall extend beyond the junction box;
- (b) all junction box covers shall be removed;
- (c) the weight specified in Table 16.31.1 shall be attached, by a wire or cord that does not contact any surface of the junction box, to a conduit fitting installed to the box so the force is applied from inside the junction box at the point most likely to result in deformation; and
- (d) after 2 min, the weights shall be removed and any permanent deformation from the original shall be measured.

**Table 16.31.1**  
**Deformation forces**

(See Clause 16.31.1.)

Number of conductors in or out	Force in pounds, lb	
	12 AWG	14 AWG
1 or 2	15	14
More than 2	30	16

16.31.2 Permanent deformation of the junction box, its hardware, or its attachment to the luminaire shall not exceed 3.2 mm (0.125 in).

### 16.32 Splice inspection

16.32.1 A short length of 14 AWG or larger wire shall be connected to the luminaire leads in the junction box or wiring compartment. The luminaire shall be mounted in the manner intended.

16.32.2 A visual inspection of the splices in the wiring compartment shall be conducted from the room side of the luminaire.

16.32.3 The connections to the branch circuit supply, including the ground, shall be visible through the luminaire access opening. All parts that are required to be removed to gain access to the splices shall be easily removed and replaced from the room side of the luminaire.

### 16.33 Lampholder mounting torque

16.33.1 A torque of 2.26 N·m (20 lb·in) shall be gradually applied to a medium-base screwshell-type lampholder and held for 1 min using the test apparatus of Clause 19.27.

16.33.2 Test results shall be acceptable if:

- (a) the lampholder remains in place;
- (b) there is no permanent deformation of the polymeric housing; and
- (c) electrical spacings comply with Clause 6.11.

### **16.34 Lampholder pull**

16.34.1 A force of 89 N (20 lb) shall be gradually applied to the screwshell of a medium-base lampholder in a straight down direction and held for 1 min using the test apparatus of Clause 19.27.

16.34.2 There shall be no permanent deformation of the polymeric housing, and electrical spacings shall comply with Clause 6.11.

### **16.35 Lampholder mounting bracket stop test**

16.35.1 The bracket that supports the lampholder shall be adjusted so that it contacts the stops. A force of 4.5 kg (10 lb) shall be applied to the lampholder support bracket for 2 min, and the displacement of the stop from the original position shall be measured.

16.35.2 The displacement of any stop shall not exceed 3.2 mm (0.125 in) from its original position. The lampholder support bracket shall not be displaced past any stop.

### **16.36 (MEX) Thermal shock**

#### **16.36.1 (MEX) Curved borosilicate glass**

16.36.1.1 (MEX) In Mexico, borosilicate glass shall be heated in an oven at a constant and controlled temperature for 15 min to establish a differential in temperature of  $75 \pm 1$  °C between the oven temperature and a cold environment (tap water). The glass shall be removed from the oven and immersed glass in the cold environment, keeping the rim of the glass 15 mm (0.59 in) above the water level. In order for the glass to be considered acceptable, the glass shall not show any breakage.

#### **16.36.2 (MEX) Tempered glass**

16.36.2.1 (MEX) In Mexico, tempered glass shall be heated in an oven at a constant and controlled temperature for 15 min to establish a differential in temperature of  $170 \pm 1$  °C between the oven temperature and a cold environment (tap water). The glass shall be removed from the oven and immersed in a flat way in the cold environment in order to produce a uniform thermal shock throughout the entire glass.

### **16.37 (MEX) Vibration**

16.37.1 (MEX) In Mexico, the luminaire shall remain in the holding device and all luminaire parts shall remain intact using the test apparatus of Clause 19.34 (MEX).

16.37.2 (MEX) In Mexico, the complete luminaire, without the lamp, shall be mounted 25 cm from the middle of the mounting point and the working plane. The mounting axis, if possible, shall be different from the vibration axis.

16.37.3 (MEX) In Mexico, the luminaire shall undergo vibration testing at 10/40/10 Hz for 20 min, summing up  $40 \pm 10$  s for each sweeping sequence. The vibration table shall be adjusted to obtain an acceleration force of  $0.125 \pm 10\%$  times the force of gravity (g) at 10 Hz and  $2.0 \pm 10\%$  at 40 Hz.

### **16.38 Lampholder lead pull**

16.38.1 A pull force of 89 N (20 lbf) shall be applied for 1 min to each conductor terminating at the lampholder in any direction permitted by the luminaire construction.

16.38.1 (MEX) In Mexico, Clause 16.38 does not apply.

16.38.2 No uninsulated live parts shall be made accessible as a result of the application of the test force.

### **16.39 Ground-screw assembly strength**

16.39.1 A 12 AWG ( $3.3 \text{ mm}^2$ ) solid-copper, insulated conductor shall be stripped to a length of 2.5 cm (1 inch) minimum. The wire shall be wrapped around the screw under the screw head so that it makes a minimum  $180^\circ$  turn. The conductor shall be seated to follow any wire guides or dimples provided to align the conductor with the mating surface. The ground screw shall be tightened with a calibrated torque screwdriver to 1.6 N·m (14 lb-in).

16.39.2 When tested as described in this section, there shall not be:

- (a) damage to the head of the ground screw which would prevent the 1.6 N·m (14 lb-in) of tightening torque to be achieved; or
- (b) stripping of the ground screw assembly.

## 16.40 Cable pull test

16.40.1 A metal junction box having an integral strain-relief mechanism for cable shall be assembled as described in Clauses 16.40.2 to 16.40.5 and subjected to the test method specified in either Clause 16.40.6 or Clauses 16.40.7 and 16.40.8, at the manufacturer's option.

16.40.2 A strain-relief mechanism intended to secure only one cable shall be tested using 1 sample of each strain-relief mechanism and intended cable AWG. A strain-relief mechanism intended to secure 2 cables under a common clamp, are to be tested using 1 sample having 1 cable and another 1 sample having 2 cables for each strain-relief mechanism and intended cable AWG.

16.40.3 Samples of the cable that comply with Clause 4.1 are to be assembled as intended to the junction box using the strain-relief mechanism. The cable or cables are to be of the size marked on the luminaire that the strain-relief mechanism is intended to secure.

16.40.4 After assembly, the cut end of the cable to extend approximately 6.4 mm (1/4 inch) beyond the strain-relief mechanism. The wires of the cable are to be allowed to project approximately 152 mm (6 inches) inside the box. A screw that can be tightened with a screwdriver is to be tightened as follows:

- (a) a screw or bolt-head screw other than a No. 8 or No. 6, that can be tightened with a screwdriver is to be tightened with a torque of 3.96 N·m (35 lbf·in). A No. 8 screw is to be tightened with a torque of 2.26 N·m (20 lbf·in) and a No. 6 screw is to be tightened with a torque of 1.36 N·m (12 lbf·in).
- (b) an un-slotted bolt-head screw, direct bearing or securing a clamp is to be wrench-tightened with a torque of 18.1 N·m (160 lbf·in).
- (c) a strain-relief mechanism that is provided with specific instructions is to be assembled and installed in accordance with the method specified by the manufacturer.

16.40.5 The free end of the cable is to be formed into a loop and securely fastened by tape or equivalent means. The pull is to be applied to the loop by a hook or other convenient method. A mechanism intended to secure more than one cable is to have the pull applied separately to each cable, one pull at a time.

16.40.6 Each sample is to be subjected to a direct pull of 267 N (60 lbs) for 5 minutes. The results shall be acceptable if the sample withstands the pull without:

- (a) damage to the cable sheath or individual conductor insulation;
- (b) displacement of more than 3.2 mm (1/8 inch) of the cable from the fitting;
- (c) loosening so that the cable can be readily removed; or
- (d) cracking, breaking, or other indication that the strain-relief mechanism has been damaged.

16.40.7 Each sample is to be subjected to a direct pull of 110 N (25 lbs) for 5 minutes. The results shall be acceptable if the cable withstands the pull without:

- (a) damage to the cable sheath or individual conductor insulation;
- (b) displacement of more than 3.2 mm (1/8 inch) of the cable from the fitting;
- (c) loosening so that the cable can be readily removed; or

(d) cracking, breaking, or other indication that the strain-relief mechanism has been damaged.

#### 16.40.8 Aging and dielectric test method

16.40.8.1 Six previously untested samples are to be subjected to the Aging and Dielectric Test. Each sample shall be prepared in the same manner as for the pull test.

16.40.8.1 (MEX) In Mexico, Clause 16.40.8 does not apply.

16.40.8.2 Each assembly is to be conditioned in an air-circulating oven for 168 hours at  $90 \pm 1^\circ\text{C}$  ( $194 \pm 1^\circ\text{F}$ ). The samples are then to be removed from the oven and cooled to room temperature before being handled. Once the cooling process is done, each sample is to be subjected to a potential of 5000 Vac for a period of 1 minute. The potential is to be applied between the insulated conductors of the cable and between the insulated conductors and the fitting or bare wire ground.

16.40.8.3 The results shall be acceptable if there is no cracking, breaking, or other indication that the strain-relief mechanism has been damaged and there is no dielectric breakdown after the oven-conditioning test.

### 16.41 Polymeric impact

16.41.1 The sample luminaires shall be held in place and subjected to a single 7 J (5 ft-lb) impact, using the impact test apparatus described in Clause 19.21, falling through a vertical height of 1.29 m (4.24 ft), on surfaces being tested. The test samples shall be conditioned by placing them in a conditioning environment in accordance with Table 16.41.1 for at least 3 h prior to the test.

**Table 16.41.1**  
**Sample conditioning**

Location marking	Preconditioning temperature
Dry	$23 \pm 2.0 \text{ C}$
Damp	$0.0 \pm 2.0 \text{ C}$
Wet	$-35 \pm 2.0 \text{ C}$

16.41.2 The number of samples and the sequence of the procedure shall be in accordance with Figure 16.2.3.1.

16.41.3 Test results shall be acceptable if the enclosure is capable of complying with all the applicable requirements of this standard.

## 17 Electrical tests

### 17.1 Dielectric voltage-withstand

17.1.1 The dielectric voltage-withstand test apparatus shall be in accordance with Clause 19.20.

17.1.2 A luminaire shall withstand for a period of 1 minute, without breakdown, a test potential applied between live parts and accessible non-current-carrying metal parts, including parts accessible only during relamping.

17.1.3 The test potential shall be 1000 V for incandescent-type luminaires and 1000 V plus twice the rated input voltage for all other types of luminaire.

17.1.4 The applied potential shall be gradually increased from zero at a uniform rate until the required test value is reached or breakdown occurs. During the test, any switches or other controls shall be in the ON position.

17.1.5 The test shall be performed on a fully assembled luminaire. Non-current-carrying parts or decorative parts not likely to become energized shall not be required to be in place.

17.1.6 Solid state components that are not relied upon to reduce the risk of electric shock and that can be damaged by the applied dielectric potential may be disconnected for the test. The circuitry may be rearranged for the purpose of the test to reduce the likelihood of solid state component damage while retaining the representative dielectric stress on the circuit.

## 17.2 Bonding circuit impedance

17.2.1 The test apparatus shall be in accordance with Clause 19.19.2. The measured resistance between the point of connection of the branch circuit equipment grounding conductor and any non-current carrying metal parts of the luminaire described in Clause 6.14.1.1 shall not exceed 0.10  $\Omega$ .

17.2.2 If the resistance measured in Clause 17.2.1 exceeds 0.10  $\Omega$  the test of Clause 17.2.4 shall be conducted.

17.2.3 The test apparatus shall be in accordance with Clause 19.19.2. The measured voltage between the point of connection of the branch circuit equipment grounding conductor and any non-current carrying metal parts of the luminaire described in Clause 6.14.1.1 under the conditions specified in 17.2.4 shall comply with 17.2.5.

17.2.4 The test of impedance shall be performed by passing a 30 A current from a part to be grounded to the grounding terminal means for a period of 2 min and measuring the potential drop between them at the end of the period.

17.2.5 When tested in accordance with Clause 17.2.4:

- (a) the resulting voltage drop shall not exceed 4.0 V; and
- (b) there shall be no melting of any conductor or metal in the bonding circuit
- (c) there shall be no heating or burning that is likely to create a fire hazard.

### 17.3 Interlock switch endurance

17.3.1 A luminaire incorporating an interlock switch shall be connected to a supply circuit and operated at rated lamp voltage, wattage, and frequency, with the switch contacts connected in the ungrounded conductor.

17.3.2 Accessible non-current-carrying metal parts of the luminaire shall be connected to the grounded conductor of the supply circuit through a 3 A quick-acting plug-type fuse.

17.3.3 The switch shall be operated by means of the interlocking mechanism provided in the luminaire for 500 cycles at a rate not exceeding 6 cycles per min.

17.3.4 Test results shall be acceptable if there is no:

- (a) electrical or mechanical malfunction of the switch;
- (b) fault indicated by opening of the fuse; and
- (c) dielectric breakdown when subjected to the dielectric voltage-withstand test of Clause 17.1.

### 17.4 Articulate probe

17.4.1 The articulate probe of Clause 19.22 shall not contact live parts when inserted through any openings in an enclosure, with the probe in every possible position. Where necessary, an electrical indicator may be used to determine whether contact is made with live parts.

### 17.5 (MEX) Insulation resistance

17.5.1 (MEX) In Mexico, the insulation resistance test apparatus shall be in accordance with Clause 19.33 (MEX).

17.5.2 (MEX) In Mexico, the insulation resistance shall be measured between live parts of opposite polarity and between live parts and the luminaire housing. The resistance measured shall be not less than 2.0 M $\Omega$ .

## 18 Factory production tests

### 18.1 Dielectric voltage-withstand

18.1.1 A dielectric voltage-withstand test shall be performed on 100 percent of production of luminaires that contain conductors that are:

- (a) not visible after assembly; or
- (b) enclosed for a distance more than 38 mm (1.50 in) within
  - (1) a stem, arm, or tubing; or
  - (2) conduit that is not listed or certified.

18.1.2 A fluorescent luminaire with the construction described in Clause 18.1.1 and provided with a removable cover for access to conductors shall not be required to be subjected to the factory dielectric voltage-withstand test.

18.1.3 The dielectric voltage-withstand test apparatus shall be in accordance with Clause 19.20.

18.1.4 Luminaires shall be fully assembled, with control and protective components in conducting position, switches in the ON position, and fuses in place. Isolated non-current-carrying metal parts or decorative parts not likely to become energized shall not be required to be in place.

18.1.5 Solid state components that are not relied upon to reduce the risk of electric shock and that can be damaged by the applied dielectric potential may be disconnected for the test. The circuitry may be rearranged for the purpose of the test to reduce the likelihood of solid state component damage while retaining the representative dielectric stress on the circuit.

18.1.6 The luminaire shall be subjected, without breakdown, to a voltage of 1200 V ac, for a duration of 1 s, between:

- (a) primary wiring and accessible non-current-carrying metal parts that can become energized; and
- (b) primary wiring and accessible uninsulated live parts in the secondary circuit of an isolating transformer rated for a maximum open circuit voltage of 30 V rms or 42.4 V peak.

## 18.2 Grounding continuity

### 18.2.1 General

18.2.1.1 A grounding continuity test shall be performed on luminaires with:

- (a) non-current-carrying metal parts that can become energized and are accessible during user maintenance; or
- (b) snap-in lampholders with integral grounding means.

18.2.1.2 The testing shall be performed as follows:

- (a) at least once per production run per design for temperature-test-exempt luminaires; and
- (b) at least once per quarter per design for all other luminaires.

18.2.1.3 The grounding continuity test apparatus shall be in accordance with Clause 19.19.

18.2.1.4 The measured or calculated resistance between the point of connection of the grounding means and any non-current-carrying metal parts described in Clause 18.2.1.1 shall not exceed 0.10  $\Omega$ .

## 18.2.2 Grounding continuity test for unassembled luminaires

18.2.2.1 A grounding continuity test shall be performed on a representative design at least once per quarter.

18.2.2.2 The grounding continuity test for a luminaire that is shipped with the enclosure unassembled, or with snap-in or tab-mounted parts, shall be conducted in the following manner:

(a) the luminaire shall be completely assembled in accordance with the assembly instructions. The grounding continuity test shall be performed after the applicable parts pull test specified in Items (b) and (c). The grounding continuity test apparatus shall be in accordance with Clause 19.19. The resistance between the two test points shall not exceed 0.10  $\Omega$ .

(b) if the assembled enclosure part is not provided with a knockout or conduit opening, the parts pull test of Clause 16.16 shall be conducted.

(c) if the assembled enclosure part is provided with a knockout or conduit opening, the parts pull test of Clause 16.17 shall be conducted.

## 18.3 Glass support

18.3.1 One sample of each luminaire style that employs a glass diffuser supported by friction alone shall be tested at least once per quarter to determine compliance with Clause 16.24.

## 18.4 Strain relief

18.4.1 One sample of each luminaire design with a power supply cord shall be tested at least once per quarter to determine compliance with the strain-relief test of Clause 16.21.1.

18.4.2 One sample of each luminaire design with a lamp-supported lampholder shall be tested at least once per quarter to determine compliance with the strain-relief test of Clause 16.21.2.

## 18.5 Polarity

18.5.1 One sample of each luminaire design required to comply with the identification and polarity requirements of Clause 6.10 shall be tested at least once per quarter to determine compliance with the polarity test of Clause 18.5.2, unless the polarity can be verified visually.

18.5.2 Continuity shall be verified between the point where the identified (neutral) branch circuit conductor is intended to be connected to the luminaire and the lampholder screwshell, using an indicating device such as an ohmmeter or other continuity testing device.

## 18.6 Ground screw torque

18.6.1 One sample of each luminaire design provided with a screw for securing the branch circuit equipment grounding conductor shall be tested at least once per quarter to determine compliance with the ground-screw assembly strength test of Clause 16.39.

## 18.7 Test records

18.7.1 Test records shall be retained for a period of at least 6 months, and shall include test quantity, test dates, catalogue or model numbers, test results, and disposition of any non-complying products.

## 19 Test procedures and apparatus

### 19.1 Installation and support

19.1.1 A luminaire shall be installed or supported to simulate intended usage, in accordance with the manufacturer's instructions. Where more than one method may be used, it shall be installed or supported to allow recording of the maximum temperature that can be encountered under the intended uses.

19.1.2 A luminaire part designed to be adjustable by the user shall be positioned or adjusted to cause maximum heating of the luminaire, mounting surface, or both. A luminaire part that is marked in accordance with Table 20.1.1, Item 2.31, shall be positioned for the temperature test in accordance with the marking.

19.1.3 A luminaire that is intended to be mounted to the floor shall have no room obstructions, ceiling, or walls closer than 0.91 m (3 ft).

19.1.4 A pole-mounted luminaire not provided with a pole shall be mounted on a representative length of pole and meet the conditions of Clause 19.1.3.

### 19.2 Temperature test stabilization

19.2.1 Temperature tests shall be conducted in accordance with Clause 19.2 and the normal and abnormal temperature tests of Clauses 14 and 15.

19.2.2 Temperatures shall be measured by thermocouples, as specified in Clause 19.7.

19.2.3 The temperature of ballast and transformer coils shall be measured using thermocouples that are directly in contact with the inner surfaces of the coil or using the rise-of-resistance method described in Clause 19.6. The resulting temperature shall not exceed the applicable temperatures specified in Table 14.1.2.

19.2.4 Temperatures shall be measured after they have stabilized, when:

- (a) the test has been running for a minimum of 7.5 h; or
- (b) the test has been running for a minimum of 3 h; and
- (c) three successive readings taken at 15 min intervals are within 1 °C of one another and are not rising.

### 19.3 Voltage

#### 19.3.1 General

19.3.1.1 The test voltages specified in Clauses 19.3.2 to 19.3.5 shall be used when conducting temperature tests.

#### 19.3.2 Incandescent luminaires, non-transformer operated

19.3.2.1 The test voltage for a standard test lamp shown in Tables 19.8.1, 19.8.2, and 19.8.3 shall be adjusted to achieve the rated lamp wattage.

19.3.2.2 The test voltage for lamps other than standard test lamps shall be adjusted to achieve the rated lamp wattage and shall be within 2 percent of the rated lamp voltage.

#### 19.3.3 Incandescent luminaires, power supply operated (transformer)

19.3.3.1 The test voltage shall be the nominal system voltage specified in Table 19.3.3.1.

**Table 19.3.3.1**  
**Voltage variation limits for circuits at utilization points**

(See Clauses 19.3.3.1, 19.3.4.1, and 19.3.5.1.)

Nominal system voltage	Rated input voltage range	
	Low voltage range	High voltage range
120/208	110 – 125	190 – 216
120/240	110 – 125	220 – 250
240/416	220 – 250	380 – 432
277/480	250 – 288	432 – 500
347/600	312 – 380	540 – 625

19.3.3.1 (MEX) In Mexico, Clause 19.3.3.1 and Table 19.3.3.1 do not apply.

19.3.3.2 The test voltage for a luminaire that employs ampere-rated automotive-type lamps shall be adjusted to the rated input voltage of the power supply.

19.3.3.2 (MEX) In Mexico, Clause 19.3.3.1 and Table 19.3.3.1 do not apply.

19.3.3.3 The test lamp, when evaluated separately, shall operate within 5 percent of the rated lamp wattage or amperage, as applicable, at rated lamp voltage.

#### 19.3.4 HID luminaires

19.3.4.1 The test voltage shall be the nominal system voltage corresponding to the rated ballast input voltage, as specified in Table 19.3.3.1.

19.3.4.1 (MEX) In Mexico, in order to determine if a luminaire meets the temperature requirements, it shall be operated at the standard frequency and voltage (120, 127, 220, 254, 277, 440, and 480 V) indicated on the ballast as long as the lamp operates at its nominal power  $\pm 5$  percent. Otherwise, the voltage of the line should be adjusted so that the lamp operates at its nominal power.

19.3.4.2 A capacitor shall have a capacitance rating within 5 percent of the ballast manufacturer's specification.

19.3.4.3 The test lamp, when evaluated in open air, using the same ballast and capacitor that will be used in the luminaire, shall operate within 5 percent of the rated lamp wattage after a 15 min stabilization period. The voltage may be adjusted to be within the 5 percent range, and this voltage shall be used as the test voltage.

#### 19.3.5 Fluorescent luminaires

19.3.5.1 The test voltage shall be the nominal system voltage corresponding to the ballast input voltage rating, as specified in Table 19.3.3.1.

### 19.4 Frequency

19.4.1 Frequency-sensitive equipment shall be tested at rated frequency, and equipment marked with more than one frequency shall be tested at the frequency that will produce the maximum temperature rise.

### 19.5 Ambient temperature

19.5.1 Tests shall be conducted in an ambient temperature of  $25 \pm 5$  °C. Ambient temperature variations above or below 25 °C shall be respectively subtracted from or added to temperatures recorded at points on the luminaire.

19.5.2 The ambient temperature shall be measured by means of a thermocouple or thermometer.

19.5.3 A thermocouple intended to measure ambient temperature shall be immersed in 15 ml (0.5 oz) of mineral oil in a glass container or attached to a metal mass of approximately 30 g (1 oz) that is within a cylindrical metal shield open at the top and bottom.

19.5.4 The glass container or cylindrical metal shield shall be placed in the horizontal plane passing through the midpoint of the luminaire's vertical axis at a horizontal distance from the luminaire equal to at least 3 times the luminaire diameter.

19.5.5 Tests may be conducted in an elevated ambient temperature, in accordance with Clause 12.4.2, at the option of the manufacturer.

## 19.6 Rise-of-resistance temperature method

19.6.1 The temperature of a coil may be determined by the rise-of-resistance method (comparing the resistance of the winding at the temperature to be measured with its resistance at a known temperature) using the formula specified in Clause 19.6.2.

19.6.1 (MEX) In Mexico, Clause 19.6 does not apply.

19.6.2 The temperature of a winding shall be calculated using the following formula:

$$T_H = \frac{R_H}{R_C} [k + A_C] - k + [A_C - A_H]$$

where:

$T_H$  = the temperature of the coil at the end of the test, °C

$A_C$  = the ambient temperature of the coil at the beginning of the test when  $R_C$  is measured, °C

$A_H$  = the ambient temperature at the end of the test when  $R_H$  is measured, °C

$R_C$  = the resistance of the coil at the beginning of the test in  $\Omega$

$R_H$  = the resistance of the coil at the end of the test in  $\Omega$

$k$  = 234.5 for copper

= 225.0 for electrical conductor grade (EC) aluminum

19.6.3 Since it is usually necessary to de-energize the winding before measuring  $R_H$ , and the resistance of the coil can change rapidly as the temperature decreases, it is sometimes necessary to determine the value of  $R_H$  at the end of the test by taking several resistance measurements at short intervals, beginning as quickly as possible after the instant of shutdown. A curve of the resistive values and time shall be plotted and extrapolated to give the value of  $R_H$  at the end of the test.

## 19.6 (MEX) Temperature rise

19.6.1 (MEX) In Mexico, in order to perform the temperature rise test, the terminals necessary for measuring the resistance in the different windings shall be pulled out. The thermocouple shall be on the hottest accessible part of the ballast.

19.6.2 (MEX) In Mexico, without energizing the ballast, the resistance shall be measured after the ballast has thermally stabilized at the ambient temperature. This shall be the cold resistance,  $r$ .

19.6.3 (MEX) In Mexico, the ballast shall be energized, and the corresponding load shall be connected. These conditions shall be maintained until the ballast reaches thermal stability.

19.6.4 (MEX) In Mexico, the ballast shall be de-energized, and least three measurements of resistance shall be taken for each winding. These shall be completed in the 5 min after cutting the power. This shall be the hot resistance,  $R$ .

19.6.5 (MEX) In Mexico, the time between cutting the line and taking the first reading shall not exceed 80 s in any case.

19.6.6 (MEX) In Mexico, the values of hot resistance versus time shall be graphed in order to obtain the hot resistance at the instant that the line was cut.

19.6.7 (MEX) In Mexico, the relationship between the average temperature and resistance shall be determined using the following formula:

$$\Delta T = R/r (k + T_1) - (k + T_2)$$

where:

$\Delta T$  = the temperature rise, °C

$R$  = the coil resistance at the end of the test,  $\Omega$

$r$  = the coil resistance at the beginning of the test,  $\Omega$

$T_1$  = the room temperature at the beginning of the test, °C

$T_2$  = the room temperature at the end of the test, °C

$k$  = 234.5 for copper

= 225.0 for aluminum

## 19.7 Thermocouples

19.7.1 Temperatures recorded at points on a luminaire shall be measured by means of thermocouples.

19.7.2 Thermocouples shall have conductors no larger than 0.21 mm<sup>2</sup> (24 AWG) and no smaller than 0.05 mm<sup>2</sup> (30 AWG). Thermocouples shall comply with the requirements specified in ASTM MNL 12 and thermocouples as listed in the table of the limits of error specified in NIST ITS 90, or ISA MC96.1. Thermocouple conductors smaller than 30 AWG may be used for miniature circuitry and components. The thermocouple junction shall be fused.

19.7.2 (MEX) In Mexico, thermocouples shall have conductors no larger than 0.21 mm<sup>2</sup> (24 AWG) and no smaller than 0.05 mm<sup>2</sup> (30 AWG). Thermocouples shall be J, K or T Type. Thermocouple conductors smaller than 0.05 mm<sup>2</sup> (30 AWG) may be used for miniature circuitry and components. The thermocouple junction shall be fused.

19.7.3 If referee temperature measurements are required, 30 AWG iron and constantan thermocouples and a potentiometer-type instrument shall be used.

19.7.4 A thermocouple junction and the adjacent thermocouple conductor shall be held in good thermal contact with the surface of the material where a temperature is being measured. Tape alone shall not be relied upon as a means to provide good thermal contact of the thermocouple junction. Acceptable means of securing a thermocouple include water glass, cyanoacrylate, melting the tip into plastic, soldering, or wedging between two surfaces.

19.7.5 A thermocouple used to measure a conductor temperature for through wiring shall be placed in contact with the conductor through a slit in the insulation and retained in place by a wrap of tape.

## 19.8 Test lamps

19.8.1 The type and wattage of lamp or lamps specified by the manufacturer shall be used for test purposes.

19.8.2 Test lamps, other than those shown in Table 19.8.2 with upper and lower temperature limits, when evaluated in open air, shall operate within 5 percent of the rated lamp wattage at rated lamp voltage.

19.8.3 Incandescent test lamps shall be seasoned for at least 45 min at 115 percent of the rated lamp voltage.

19.8.4 Incandescent reflector test lamps shall be of the widest beam spread available. A Type MR test lamp shall have a dichroic reflector.

19.8.5 Fluorescent and HID test lamps shall be seasoned for at least 100 h.

19.8.6 Fluorescent and HID lamps used for a temperature test shall be rated for the ballast involved.

19.8.7 The rated wattage of any test lamp for a surface ceiling-mounted luminaire shall be the maximum lamp wattage marked on the luminaire or the wattage of the largest lamp specified in Table 19.8.4 that can fit in the luminaire, whichever is larger.

**Table 19.8.1**  
**Incandescent test lamps for normal temperature tests**

(See Clauses 14.5.2, 14.6.2, 14.7.2, 15.3.1.5, and 19.3.2.1.)

Rated lamp watts	Lamp type		
	Candelabra	Intermediate	Mogul
15	B10		
25	B10	T8	
30			
40	B10	T6-1/2	
50			
60	B10		
75			
100			
150			
200			PS30
300			PS35
500			PS35

**Table 19.8.2**  
**Standard incandescent test lamps for normal temperature tests**

(See Clauses 14.5.2, 14.6.2, 14.7.2, 15.2.5, 15.3.1.5, 15.4.3.4, 19.3.2.1, and 19.8.2)

Rated watts	Lamp type	Lower limit, °C	Upper limit, °C
<b>Nonreflector lamps</b>			
25	CA-9		
40	A-19	37.4	39.8
60	A-19	42.8	46.9
75	A-19	44.2	46.4
100	A-19	53.0	57.9
150	A-21	62.2	71.4
200	A-23	76.9	82.3
300	PS-25	94.6	111.2
<b>Type R reflector lamps</b>			
30	R20	31.2	33.5
50	R20	35.2	39.2
75	R20		
50	R30		
100	R30		
75	R40	43.7	48.5
150	R40	60.8	69.5
300	R40		
<b>Type BR Reflector Lamps</b>			
40	BR30		
45	BR30		
60	BR30		
65	BR30	42.9	46.1
75	BR30	41.0	42.6
85	BR30		
65	BR40		

Table 19.8.2 Continued on Next Page

**Table 19.8.2 Continued**

Rated watts	Lamp type	Lower limit, °C	Upper limit, °C
75	BR40	42.1	45.1
85	BR40		
90	BR40	57.6	60.3
120	BR40		
150	BR40	52.4	64.5
200	BR40		
300	BR40		
<b>Type ER reflector lamps</b>			
50	ER30		
75	ER30		
<b>Type PAR reflector lamps</b>			
65	PAR38		
75	PAR38		
85	PAR38		
100	PAR38		
120	PAR38		
150	PAR38		
250	PAR38		
<b>Type PAR tungsten-halogen reflector lamps</b>			
40	PAR16	32.8	34.7
60	PAR16		
50	PAR20		
60	PAR30S		
50	PAR30L		
75	PAR30L		
45	PAR38		
60	PAR38		
75	PAR38		
90	PAR38		
100	PAR38		
120	PAR38		
<b>Special purpose lamps (infrared heat)</b>			
125	R-40	51.5	57.0
250	R-40	71.3	81.7
<p>NOTES</p> <p>(1) The lower and upper temperatures are measured in the CSA lamp temperature apparatus described in CSA C22.2 No. 84.</p> <p>(2) All standard test lamps are E26 Edison medium screw base.</p> <p>(3) Rated voltage is 120 V.</p> <p>(4) Operating position is universal.</p>			

**Table 19.8.3**  
**Standard incandescent test lamps for abnormal temperature tests**

(See Clauses 15.4.2.4, 15.4.2.5, and 19.3.2.1.)

<b>Lamp type – medium base</b>			
<b>Arbitrary (Type A)</b>			
<b>Rated lamp</b>		<b>Test lamp</b>	
<b>Watts</b>	<b>Size</b>	<b>Watts</b>	<b>Size</b>
40	A19	60	A19
60	A19	100	A19
75	A19	100	A19
100	A19	150	A21
150	A21	300	PS25
200	A23	300	PS25
300	PS25	N/A	N/A
<b>Type R reflector lamps</b>			
<b>Rated lamp</b>		<b>Test lamp</b>	
<b>Watts</b>	<b>Type</b>	<b>Watts</b>	<b>Type</b>
30	R20	50	R20
50	R20	75	R20
75	R20	150	R40
50	R30	75	R30
75	R30	150	R40
100	R30	150	R40
75	R40	150	R40
100	R40	150	R40
150	R40	300	R40
200	R40	300	R40
300	R40	N/A	N/A
<b>Type BR reflector lamps</b>			
<b>Rated lamp</b>		<b>Test lamp</b>	
<b>Watts</b>	<b>Type</b>	<b>Watts</b>	<b>Type</b>
40	BR30	60	BR30
45	BR30	75	BR30
60	BR30	90	BR40
65	BR30	120	BR40
75	BR30	120	BR40
85	BR30	150	BR40
65	BR40	120	BR40
75	BR40	120	BR40
85	BR40	150	BR40
90	BR40	150	BR40
120	BR40	200	BR40
150	BR40	300	BR40
200	BR40	300	BR40
300	BR40	N/A	N/A
<b>Type ER reflector lamps</b>			
<b>Rated lamp</b>		<b>Test lamp</b>	
<b>Watts</b>	<b>Type</b>	<b>Watts</b>	<b>Type</b>
50	ER30	75	ER30
75	ER30	150	ER30
150	ER30	N/A	N/A

Table 19.8.3 Continued on Next Page

**Table 19.8.3 Continued**

Type PAR reflector lamps			
Rated lamp		Test lamp	
Watts	Type	Watts	Type
65	PAR38	100	PAR38
75	PAR38	150	PAR38
85	PAR38	150	PAR38
100	PAR38	150	PAR38
150	PAR38	250	PAR38
250	PAR38	N/A	N/A
Type PAR tungsten-halogen reflector lamps			
Rated lamp		Test lamp	
Watts	Type	Watts	Type
40	PAR16	60	PAR16
60	PAR16	90	PAR38
50	PAR20	75	PAR30L
60	PAR30S	90	PAR38
50	PAR30L	75	PAR30L
75	PAR30L	120	PAR38
45	PAR38	75	PAR38
60	PAR38	90	PAR38
75	PAR38	120	PAR38
90	PAR38	N/A	N/A
100	PAR38	N/A	N/A
120	PAR38	N/A	N/A

**Table 19.8.4**  
**Minimum test lamp wattage for ceiling surface-mounted luminaires, W per lampholder**  
 (See Clause 19.8.7.)

Number of lamps*	Intermediate and candelabra	Medium	Medium†	Mogul
1	40	60	60	300
2	25	60	60	300
3	25	60	40	300
4	15	60	25	300
5 or more	‡	‡	‡	‡

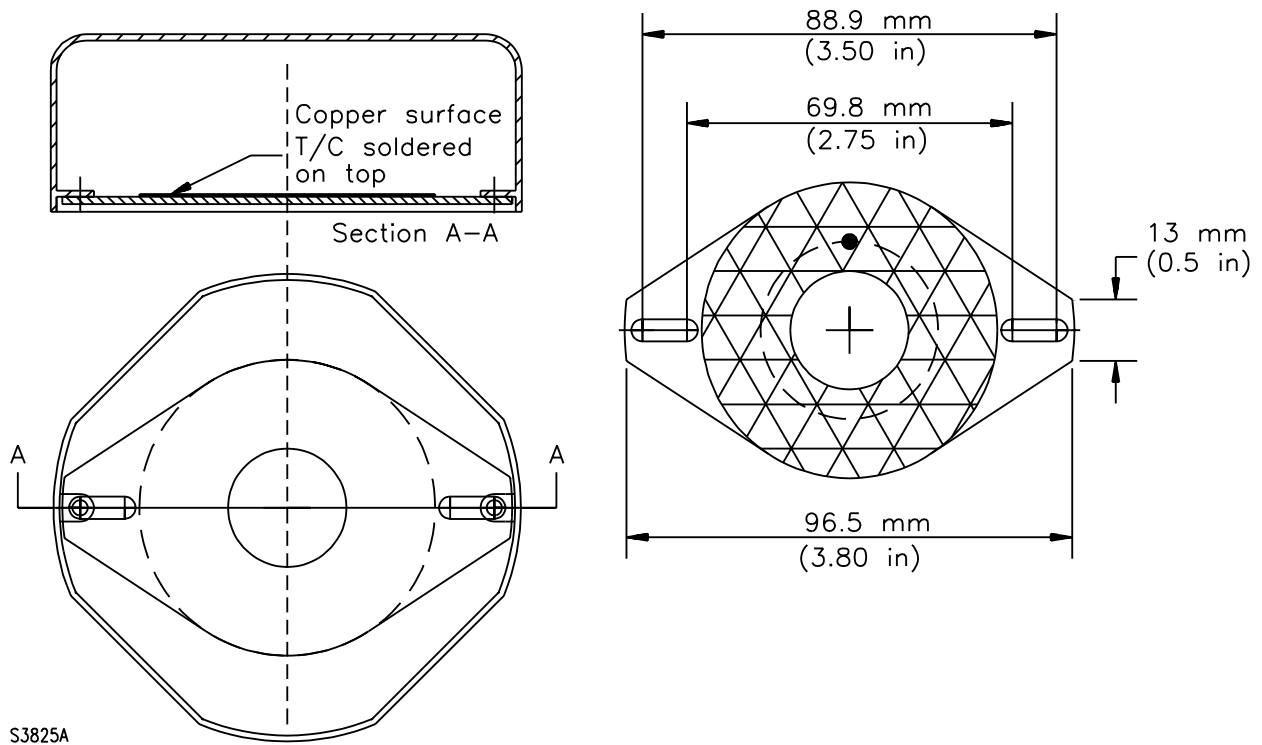
\* Numbers are applicable per lampholder type for luminaires with more than one type.  
 †This column is applicable only to luminaires in which the lamps are visible in normal use and are part of the decorative design.  
 ‡Tests may be made at any lamp wattage consistent with marking on the luminaire.

## **19.9 Branch circuit conductor temperature probe**

19.9.1 The temperature probe shown in Figure 19.9.1 shall be positioned in the outlet box adjacent to the outlet box mounting tabs, as shown, by a mechanical means, to determine the temperature of the branch circuit conductors during the temperature test.

**Figure 19.9.1**  
**Branch circuit temperature probe**

(See Clauses 14.2.7, 14.3.3, and 19.9.1.)



NOTES

- (1) Material: printed circuit board G10 epoxy/glass 2 oz. copper.
- (2) Copper 25.4 mm (1 in) ID 63.5 mm (2.5 in) OD.
- (3) Slots 4.7 mm (0.187 in) wide 14.3 mm (0.563 in) long.
- (4) Thermocouple (T/C) on 38 mm (1.5 in) diameter circle.
- (5) It is sometimes necessary to drill clearance holes, twice the diameter of the screw, through the probe in order to accommodate projecting mounting screws.

## 19.10 Surface ceiling temperature test apparatus

19.10.1 The temperature test ceiling apparatus shall conform to Figure 19.10.1 and shall be constructed as follows:

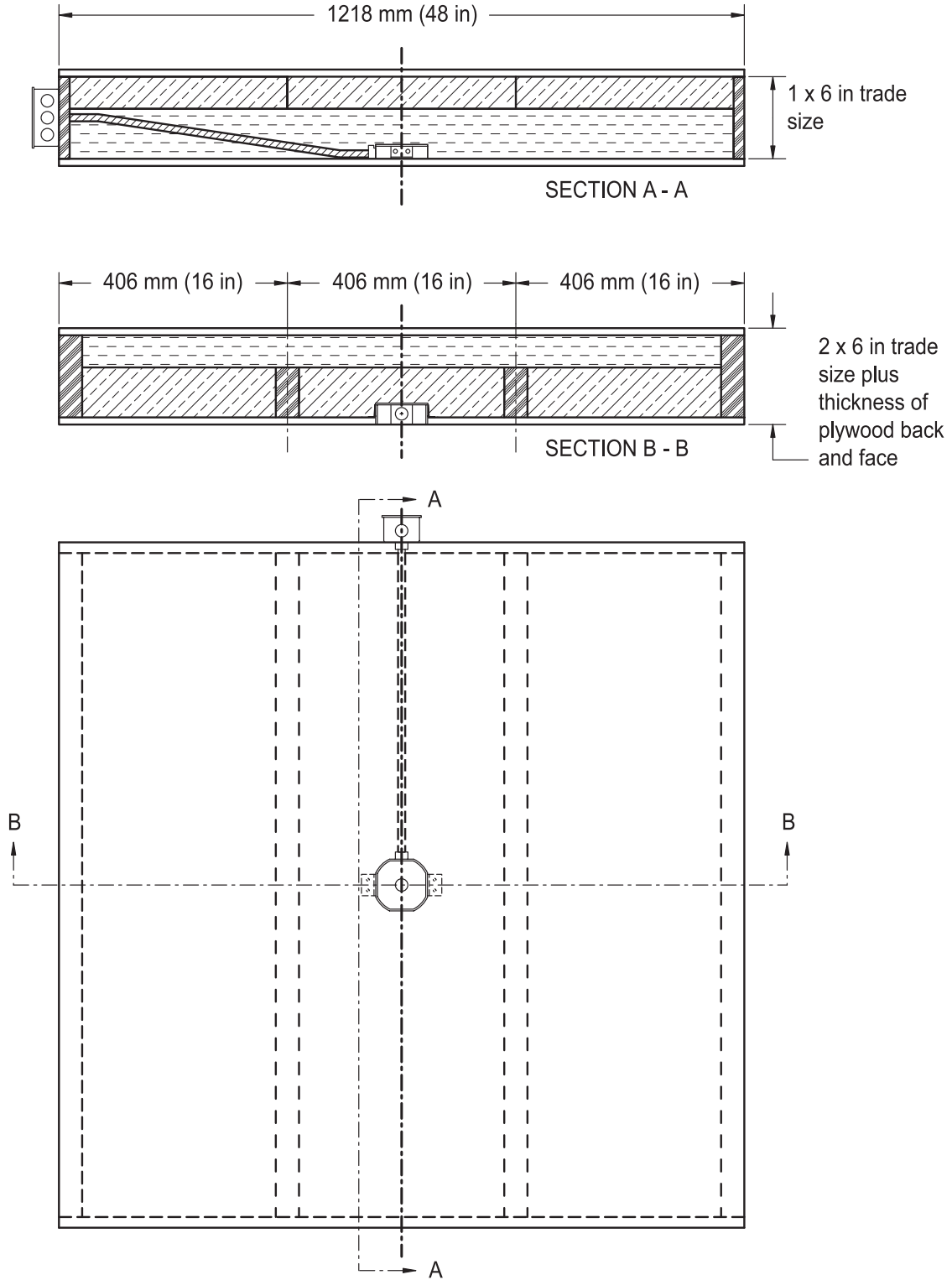
- (a) wooden parts of the structure shall be secured together with wood screws or nails.
- (b) wooden parts of the structure shall be as follows:
  - (1) the face and back shall be plywood conforming to Clause 19.32, 1218 mm (48 in) square.
  - (2) the sides shall be 2 x 6 in trade size wooden members.
  - (3) the ends shall be 1 x 6 in trade size wooden members.
  - (4) the inside supports shall be 2 x 4 in trade size wooden members.
- (c) a metal octagonal outlet box, 4 x 1-1/2 in trade size, shall be securely mounted in the center of the plywood panel, projecting through and flush with the outer face. One method of mounting the box is with steel angle brackets attached to opposite sides of the box and secured with wood screws to the inside of the plywood panel.
- (d) a metal surface utility box with cover may be mounted to the side of the structure to facilitate ease of making branch circuit connections. A 4 x 2-1/2 x 1-3/4 in trade size box is suitable for this purpose.
- (e) flexible metal or nonmetallic conduit may be installed between the outlet box and the utility box to facilitate replacing damaged conductors.
- (f) wiring shall consist of one white and one black 14 AWG conductor of any type, and one 16 AWG or larger conductor, bonding the boxes together.
- (g) the test ceiling apparatus shall be filled with two layers of faced or unfaced glass fiber insulation batts positioned at 90 degrees to each other. The insulation batts shall be approximately 89 mm (3.5 in) thick and Rsi 1.4 to Rsi 1.9 (R8 to R11), positioned directly in contact with the outlet box and slit to completely surround the flexible metal conduit.

19.10.2 Thermocouples may be routed through the flexible conduit to the outlet box.

19.10.3 The test ceiling apparatus shall be mounted in a draft-free room, and shall be located not less than 1800 mm (72 in) above the floor, a minimum of 300 mm (12 in) below the room ceiling, and a minimum of 600 mm (24 in) from any wall or other obstruction.

**Figure 19.10.1**  
**Surface ceiling temperature test apparatus**

(See Clauses 14.2.5, and 19.10.1.)



su0113

### 19.11 Surface wall temperature test apparatus

19.11.1 The temperature test wall apparatus shall conform to Figure 19.11.1 and shall be constructed as follows:

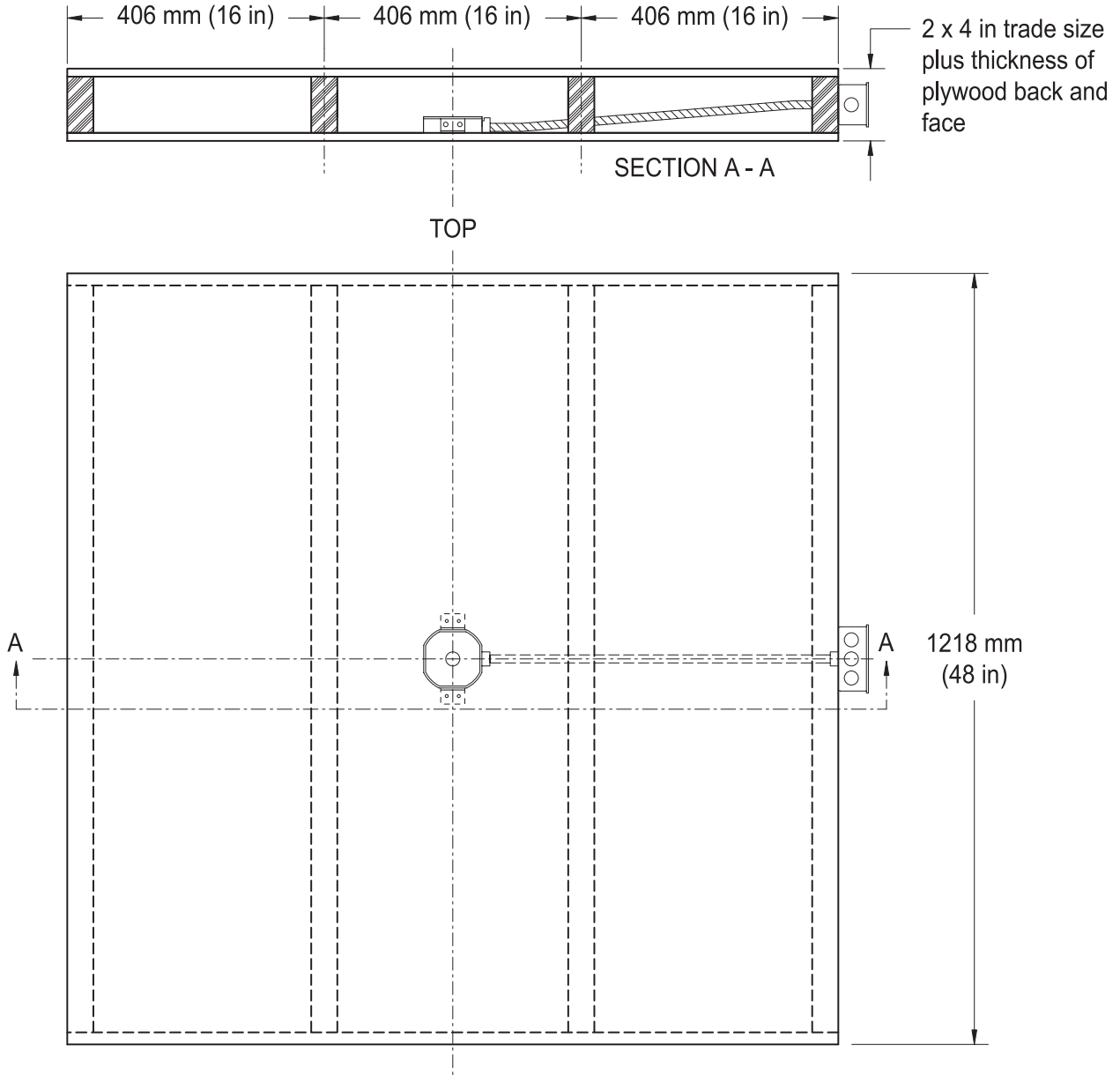
- (a) wooden parts of the structure shall be secured together with wood screws or nails.
- (b) wooden parts of the structure shall be as follows:
  - (1) the face and back shall be plywood conforming to Clause 19.32, 1218 mm (48 in) square.
  - (2) the sides shall be 2 x 4 in trade size wooden members.
  - (3) the ends shall be 1 x 4 in trade size wooden members.
  - (4) the inside supports shall be 2 x 4 in trade size wooden members.
- (c) a metal octagonal outlet box, 4 x 1-1/2 in trade size, shall be mounted in the center of the plywood panel, projecting through and flush with the outer face. The box shall be mounted with two steel angle brackets, 1.25 mm (0.050 in) thick, 38 mm (1.5 in) long, 25 mm (1 in) flanges, attached to opposite sides of the box and secured with wood screws to the inside of the plywood panel.
- (d) a metal surface utility box with cover, 4 x 2-1/2 x 1-3/4 in trade size, shall be mounted to the side of the structure.
- (e) flexible metal conduit, 3/8 in trade size, shall be installed between the outlet box and the utility box and secured with straight connectors.
- (f) wiring shall consist of one white and one black 14 AWG conductor of any type, and one 16 AWG conductor, bonding the boxes together.
- (g) the test wall apparatus shall not be filled with insulation.

19.11.2 Thermocouples may be routed through the flexible conduit to the outlet box.

19.11.3 The test wall shall be mounted in a draft-free room, and shall be located a minimum of 900 mm (36 in) above the floor and a minimum of 300 mm (12 in) below the room ceiling, with the 1 x 4 in ends in a horizontal position.

**Figure 19.11.1**  
**Test wall apparatus — wall surface luminaires**

(See Clause 19.11.1.)



su0150

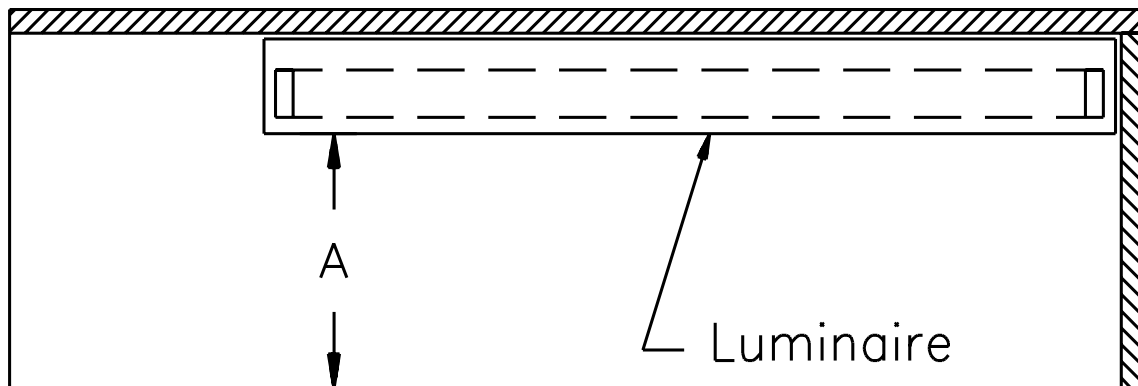
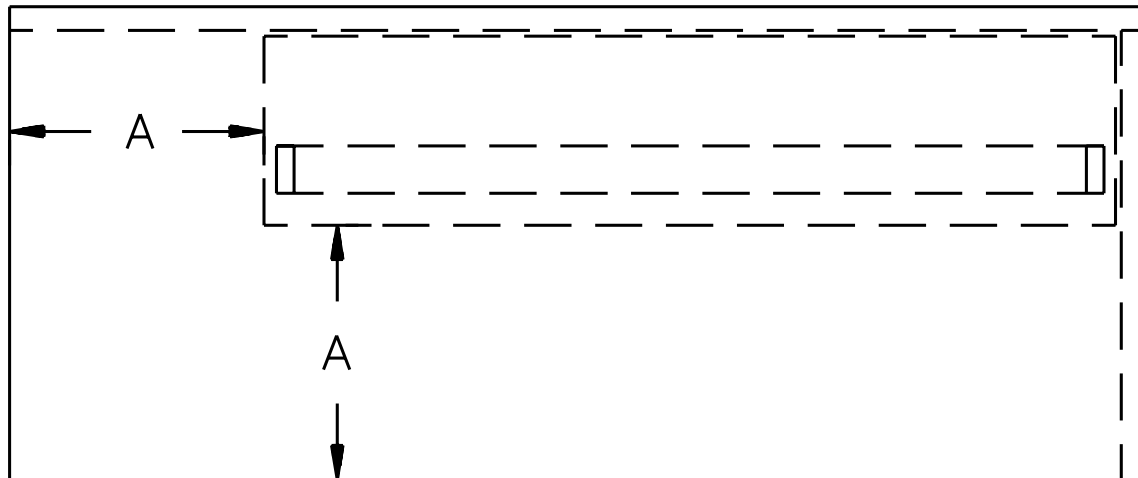
**19.12 Surface-mounted under-cabinet luminaire test alcove**

19.12.1 The test alcove shown in Figure 19.12.1 shall have three sides made of plywood conforming to Clause 19.32, joined at right angles to form a corner with butt-fitted seams secured by wood screws or nails. Each side shall project 300 mm (12 in) beyond the luminaire.

19.12.2 The luminaire shall be mounted inside so it touches two walls and the top of the alcove, in the configuration and orientation that result in the highest temperatures.

**Figure 19.12.1**  
**Surface-mounted under-cabinet test alcove**

(See Clause 19.12.1.)



S3828B

NOTES

- (1) The upper drawing is the top view.
- (2) The lower drawing is a section through the center of the top view.
- (3) Dimension A is 300 mm (12 in).

### **19.13 Temperature test boxes for Type Non-IC recessed luminaires (not intended for thermal insulation contact)**

#### 19.13.1 General

19.13.1.1 The test box shall be rectangular and have four sides, a top, and a bottom, constructed of plywood conforming to Clause 19.32, with butt-fitted seams secured with wood screws or nails. The bottom or front represents the mounting surface in which a hole is cut for the ceiling or wall aperture, respectively.

19.13.1.2 The following parts may contact the test box:

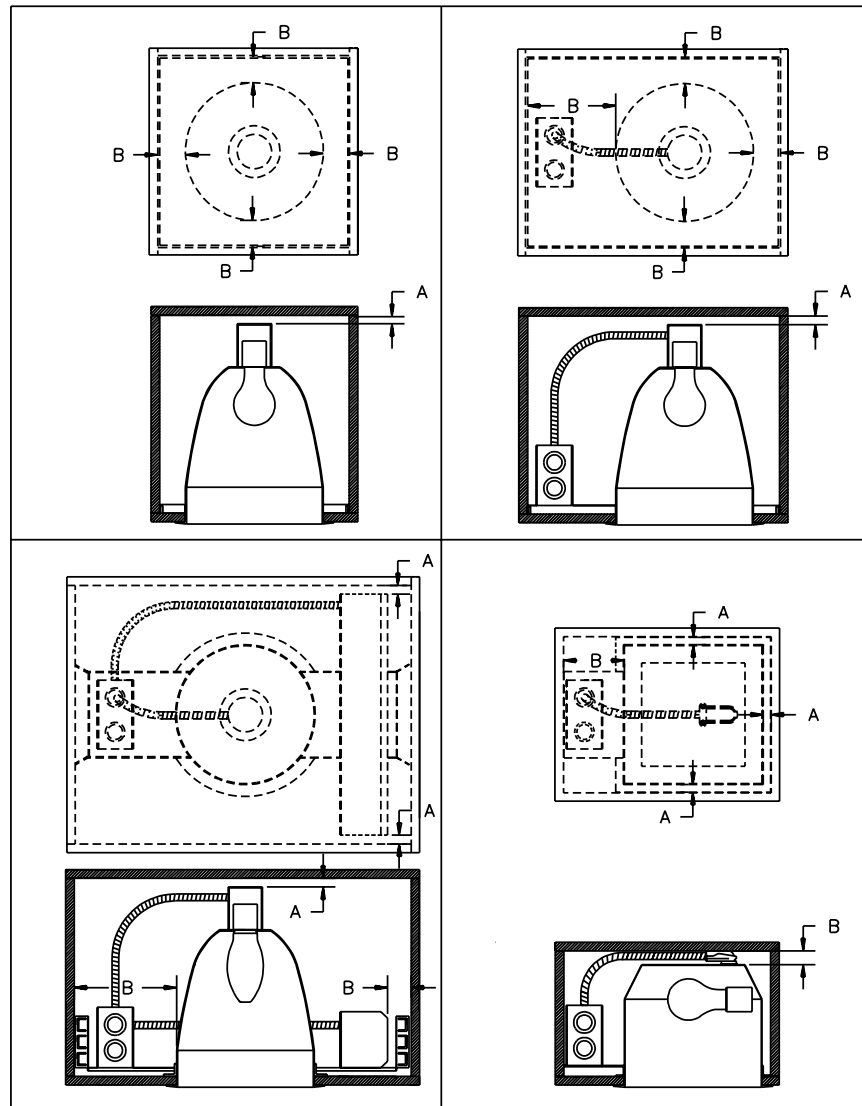
- (a) raceways, such as flexible conduit;
- (b) cable and conduit connectors; and
- (c) fittings used to fasten hoses in air-handling luminaires.

#### 19.13.2 Normal temperature test

19.13.2.1 The sides and top of the test box as shown in Figure 19.13.2.1 for a ceiling- or wall-mounted luminaire shall be 13 mm (0.5 in) from the lamp housing or heat-producing components, or shall be in contact with permanently attached parts that are more than 13 mm (0.5 in) from the lamp housing or heat-producing components.

**Figure 19.13.2.1**  
**Normal temperature test box for Type Non-IC recessed ceiling-mounted luminaires (not intended for thermal insulation contact)**

(See Clause 19.13.2.1.)



S3829A

NOTES

- (1) The upper drawing is the top view.
- (2) The lower drawing is the side section through the center of the top view.
- (3) Dimension A is 13 mm (0.5 in).
- (4) Dimension B is more than 13 mm (0.5 in) and permanently attached parts are in contact with the test box.

19.13.2.2 Holes for conduit entrance, thermocouple leads, and supply leads shall be sealed.

### 19.13.3 Abnormal temperature test

19.13.3.1 The four sides of the test box as shown in Figure 19.13.3.1 for a ceiling-mounted luminaire shall be a minimum distance of 215 mm (8.5 in) from the nearest part of the lamp housing or from other parts enclosing heat-producing components such as lamps or through-wiring junction boxes. The top edge of the sides of the test box shall be a minimum of 215 mm (8.5 in) above the highest point of any permanently attached part of the lamp housing.

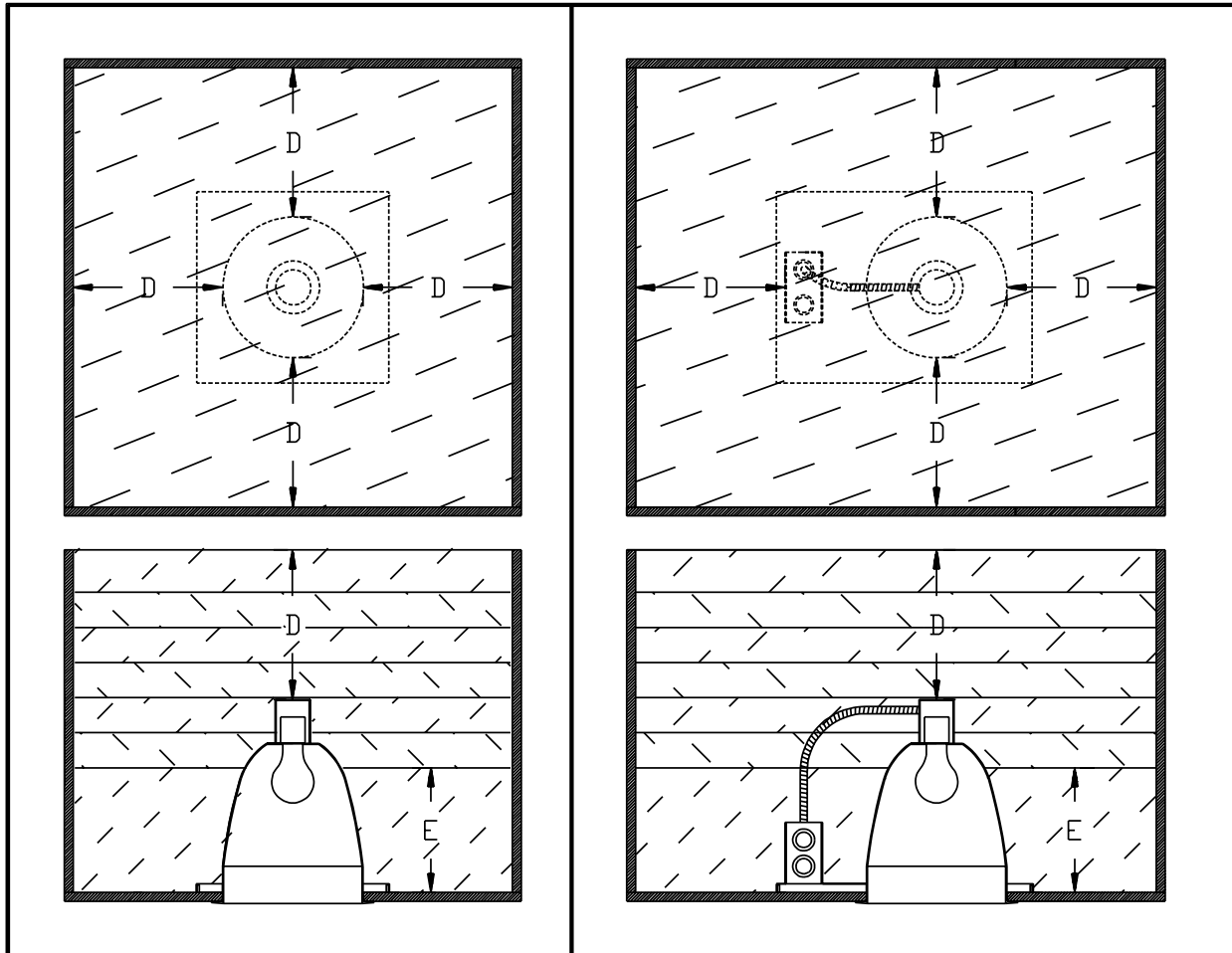
19.13.3.2 Thermal insulation of the loose-fill type specified in Clause 19.16 shall be poured into the test box through the open top, in progressive layers, without applying any compacting procedure.

19.13.3.3 The four sides of the test box shown in Figure 19.13.3.2 for a wall-mounted luminaire shall be a minimum distance of 215 mm (8.5 in) from the lamp housing or heat-producing components. The depth of the box shall be 150 mm (6 in) or, if the luminaire is deeper, a dimension that provides contact with the back of the lamp housing.

19.13.3.4 Thermal insulation of the loose-fill type specified in Clause 19.16 shall be poured into the test box through the open top, without applying any compacting procedure, until the box is full.

**Figure 19.13.3.1**  
**Abnormal temperature test box for Type Non-IC recessed ceiling-mounted luminaires (not intended for thermal insulation contact)**

(See Clause 19.13.3.1.)



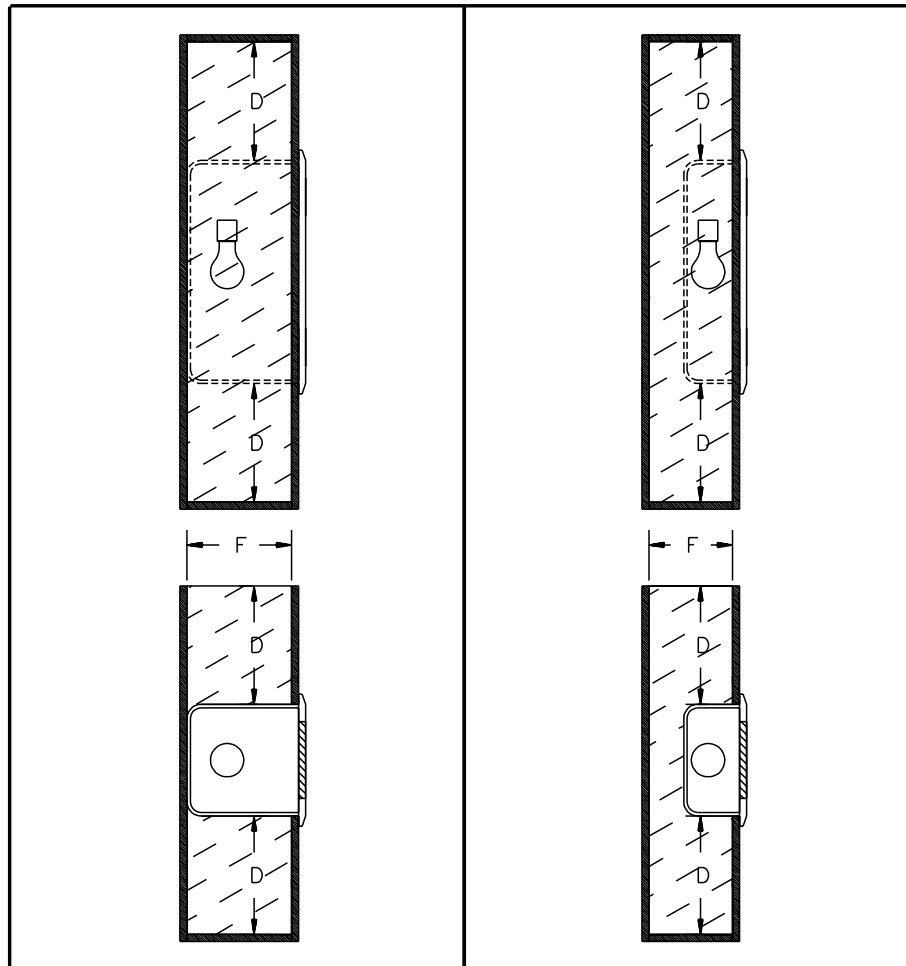
S4064

NOTES

- (1) The upper drawing is a top view.
- (2) The lower drawing is the side view through the center of the top view, showing the incremental layers of insulation.
- (3) Dimension D is a minimum of 215 mm (8.5 in).
- (4) Dimension E is a minimum of 100 mm (4 in) of insulation, or a level 50 mm (2 in) above the lowest glass envelope of the lamp.

**Figure 19.13.3.2**  
**Abnormal temperature test box for Type Non-IC recessed wall-mounted luminaires (not intended for thermal insulation contact)**

(See Clause 19.13.3.3.)



S3831A

NOTES

- (1) The upper drawing is a top view.
- (2) The lower drawing is the side section through the center of the top view, shown with insulation.
- (3) Normal temperature test without insulation.
- (4) Abnormal temperature test with insulation.
- (5) Dimension D is 215 mm (8.5 in) minimum.
- (6) Dimension F is 150 mm (6 in) or, if the luminaire is deeper, a dimension that provides contact with the back of the lamp housing.

**19.14 Temperature test box for Type Non-IC, marked spacings, recessed ceiling-mounted luminaires (not intended for thermal insulation contact)**

19.14.1 Marked spacings normal temperature test

19.14.1.1 The test box shown in Figure 19.14.1.1 shall be square and shall have four sides, a top, and a bottom constructed of plywood conforming to Clause 19.32, with butt-fitted seams secured with wood screws or nails.

19.14.1.2 The luminaire light aperture center, as shown in Figure 19.14.1.2, shall be located in a hole cut in the center of the surface of the test box that represents the ceiling surface.

19.14.1.3 The inside length of each of the four sides of the test box shall be twice the light aperture center to the building side wall marked on the luminaire, as shown in Table 19.14.1.1 and Figure 19.14.1.1.

19.14.1.4 The inside height of the test box shall be the measured height of the luminaire plus the spacing, as marked on the luminaire, to an overhead building member.

19.14.1.5 Holes for conduit entrance, thermocouple leads, and supply leads shall be sealed.

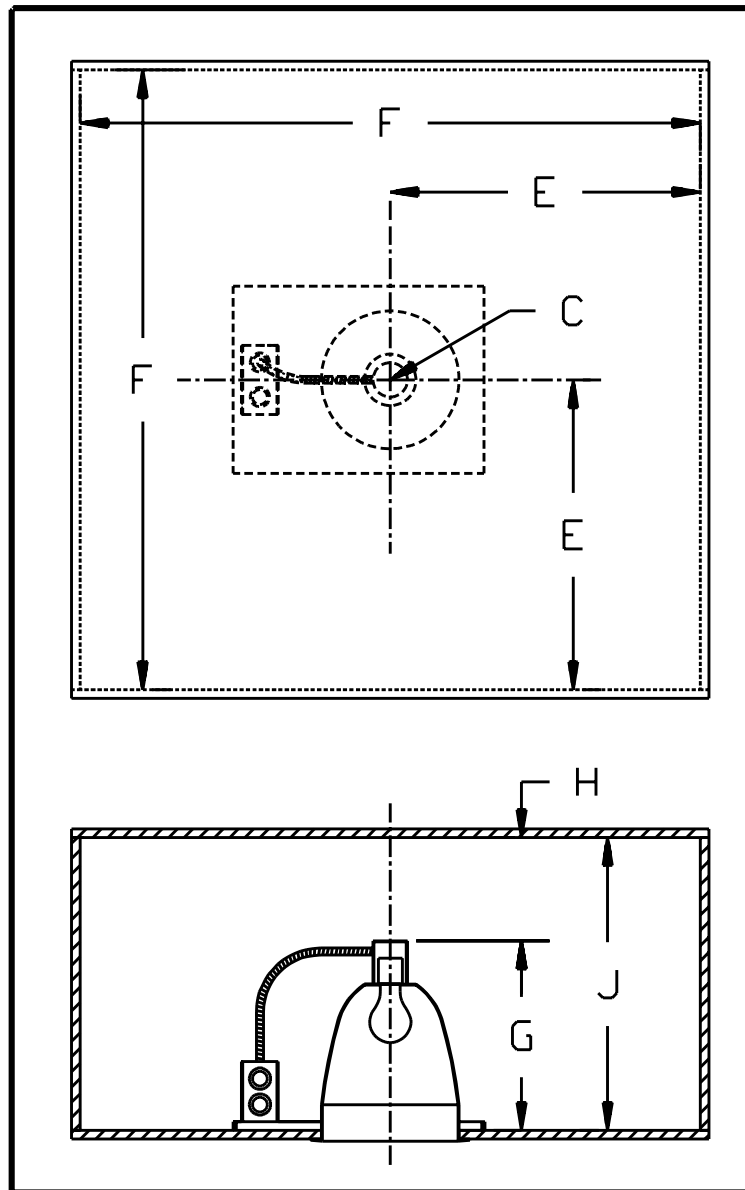
**Table 19.14.1.1**  
**Marked spacing test box inside dimensions for normal temperature tests**

(See Clause 19.14.1.3.)

Center-to-center of adjacent luminaires,		Luminaire center to side building member,		Inside length and width of test box,		Inside height of test box
mm	(in)	mm	(in)	mm	(in)	
600	(24)	300	(12)	600	(24)	Luminaire height plus marked spacing from top of luminaire to overhead building member
900	(36)	450	(18)	900	(36)	
1200	(48)	600	(24)	1200	(48)	
1500	(60)	750	(30)	1500	(60)	
1800	(72)	900	(36)	1800	(72)	

**Figure 19.14.1.1**  
**Marked spacings test box normal temperature**

(See Clauses 11.8.3.1, 19.14.1.1, and 19.14.1.3.)



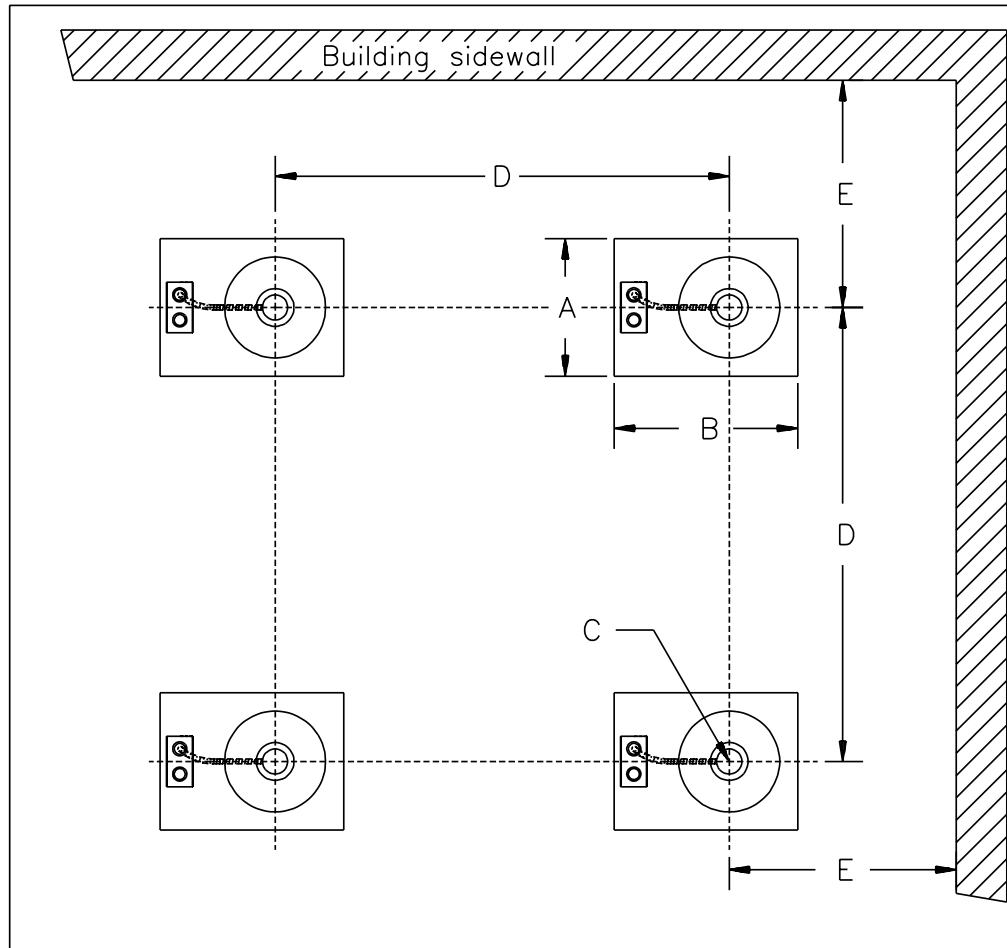
**Notes:**

- C – Light aperture center.
- E – Light aperture center to inside of test box.
- F – Inside test box side length. (2 x Dimension E)
- G – Luminaire height. (Bottom inside of test box to top of permanently attached parts)
- H – Top of lamp housing to inside of test box.
- J – Inside height of the test box. (Dimensions G + H)

S3847

**Figure 19.14.1.2**  
**Recessed luminaire mounting spacings – Type Non-IC marked spacings (not intended for thermal insulation contact)**

(See Clauses 11.8.3.1 and 19.14.1.2.)



S3832A

Top view – luminaire spacing

Legend:

A = width of luminaire

B = length of luminaire

C = light aperture center

D = light aperture center-to-center spacing (2 x dimension E)

E = light aperture center to combustible side building member

#### 19.14.2 Marked spacings abnormal temperature test – reduced spacings

19.14.2.1 The test box shown in Figure 19.14.2.1 shall be rectangular and shall have four sides, a top, and a bottom constructed of plywood panels conforming to Clause 19.32, with butt-fitted seams secured with wood screws or nails. The bottom shall represent the mounting surface in which a hole shall be cut for the ceiling aperture.

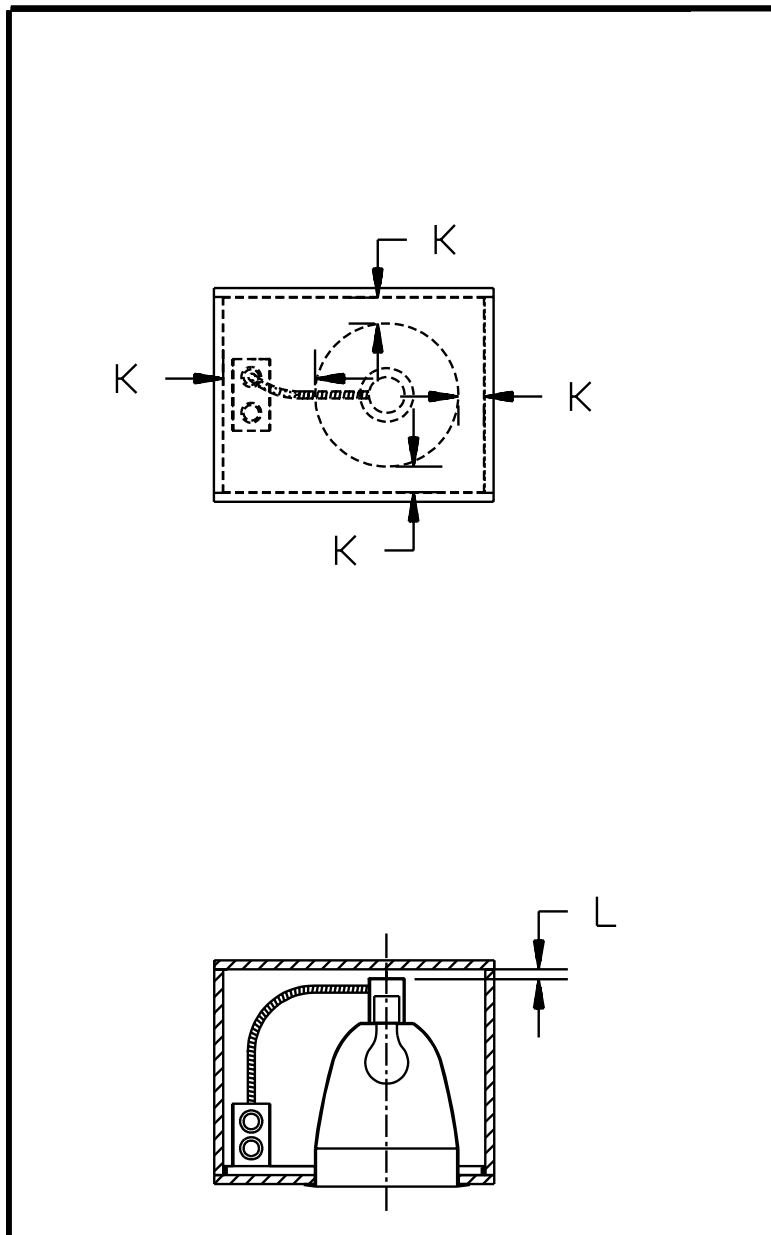
19.14.2.2 Holes for conduit entrances, thermocouples, and supply leads shall be sealed.

19.14.2.3 The sides and top of the test box shall be 13 mm (0.5 in) from the lamp housing or other heat-producing components, or shall be in contact with permanently attached parts that are more than 13 mm (0.5 in) from the lamp housing or other heat-producing components.

19.14.2.4 The following parts may contact the test box:

- (a) raceways, such as flexible conduit;
- (b) cable and conduit connectors; or
- (c) fittings used to fasten hoses in air-handling luminaires.

**Figure 19.14.2.1**  
**Marked spacings test box abnormal temperature — reduced spacings**  
 (See Clause 19.14.2.1.)



S3848A

Legend:

K = side of lamp housing to inside of test box, 13 mm (0.5 in)

L = top of lamp housing to inside of test box, 13 mm (0.5 in) or in contact

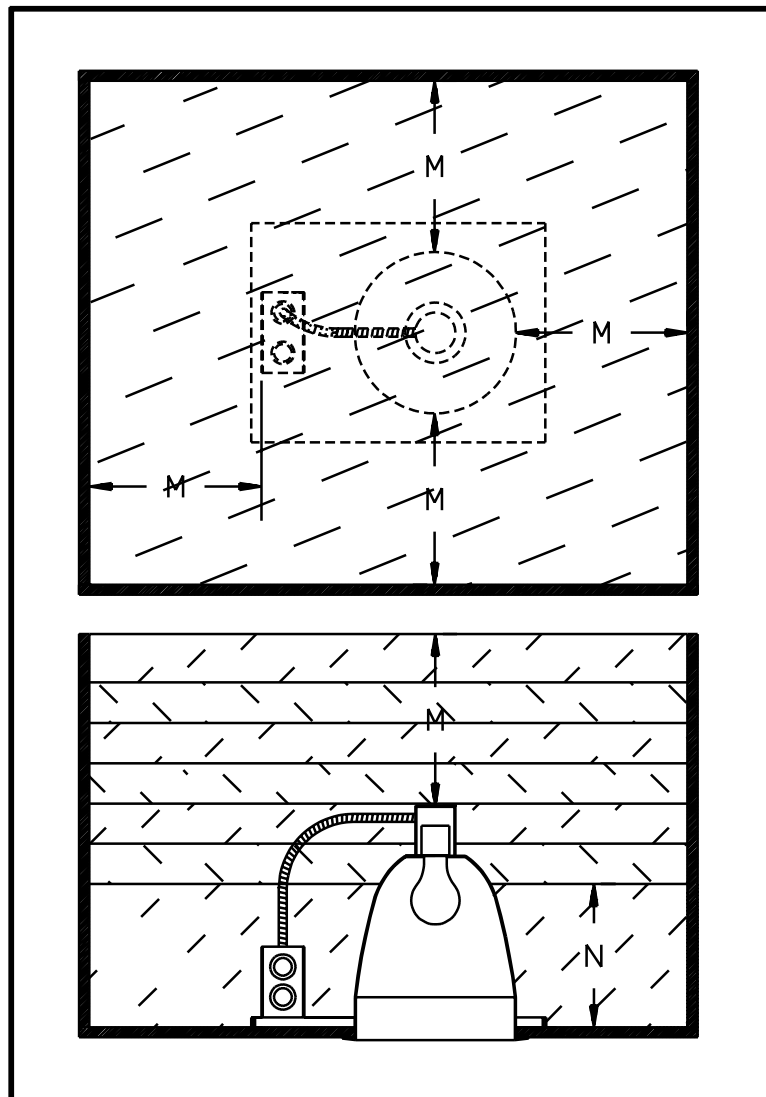
### 19.14.3 Marked spacings abnormal temperature test – thermal insulation

19.14.3.1 The test box shown in Figure 19.14.3.1 shall be rectangular and shall have four sides and a bottom constructed of plywood panels conforming to Clause 19.32, with butt-fitted seams secured with wood screws or nails. The bottom shall represent the mounting surface in which a hole shall be cut for the ceiling aperture.

19.14.3.2 The four sides of the test box shall be a minimum distance of 215 mm (8.5 in) from the nearest part of the lamp housing or other heat-producing components. The top edge of the sides of the test box shall be a minimum of 215 mm (8.5 in) above the highest point of the lamp housing.

19.14.3.3 Thermal insulation of the loose-fill type specified in Clause 19.16 shall be poured into the test box through the open top, in progressive layers, without applying any compacting procedure.

**Figure 19.14.3.1**  
**Marked spacings test box abnormal temperature — thermal insulation**  
 (See Clause 19.14.3.1.)



S3833A

NOTES

- (1) The upper drawing is a top view.
- (2) The lower drawing is a side section.
- (3) Dimension M is 215 mm (8.5 in) from the nearest part of the lamp housing or other heat-producing products.
- (4) Dimension N is a minimum of 100 mm (4 in) of insulation, or a level 50 mm (2 in) above the lowest glass envelope of the lamp.

**19.15 Temperature test box for Type IC recessed luminaires (intended for thermal insulation contact)**

19.15.1 The test box shall be rectangular and shall have four sides and a bottom constructed of plywood panels conforming to Clause 19.32, with butt-fitted seams secured with wood screws or nails. The bottom or front shall represent the mounting surface in which a hole shall be cut for the ceiling or wall aperture, respectively.

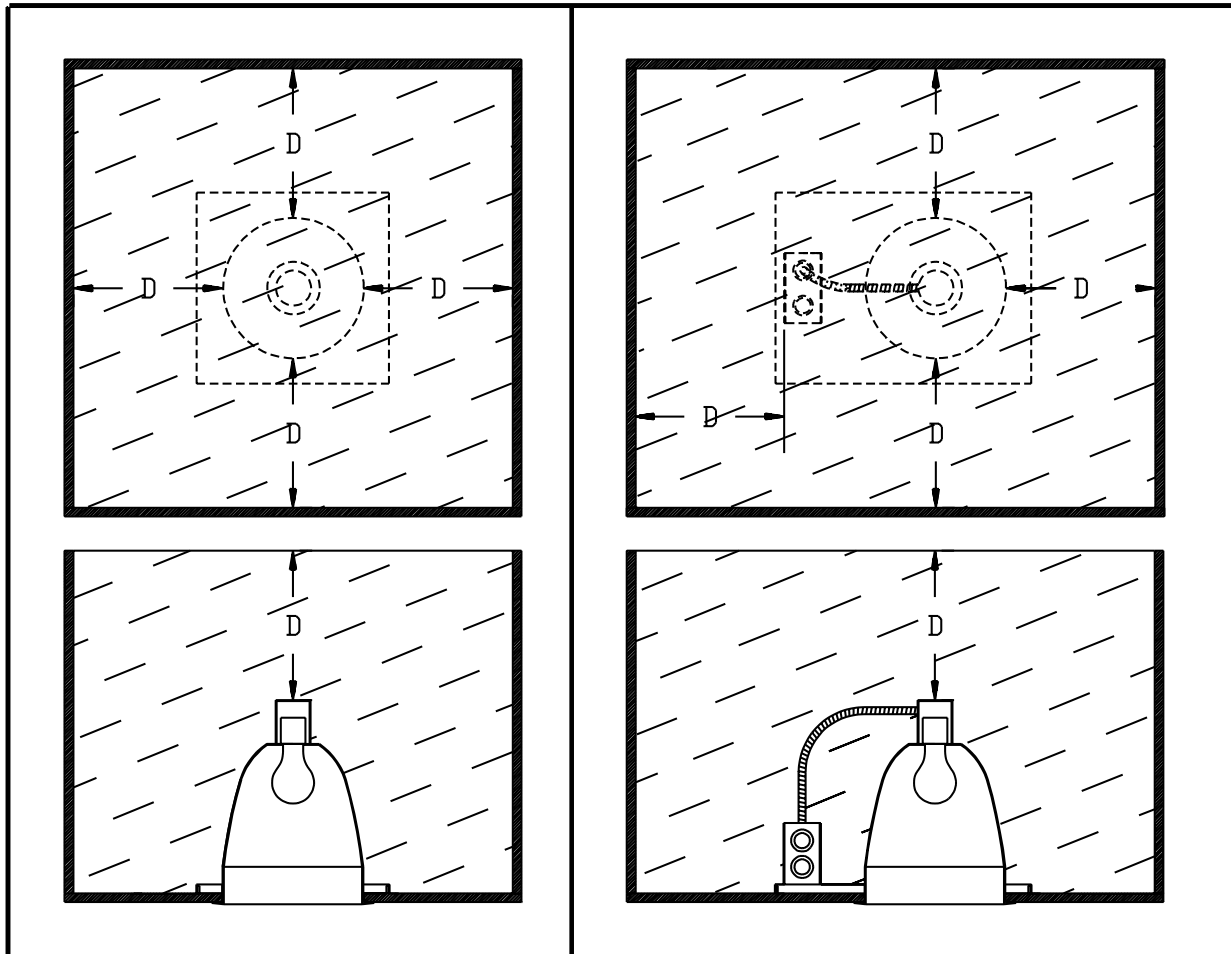
19.15.2 The four sides of the test box shown in Figure 19.15.1 for a ceiling-mounted luminaire shall be a minimum distance of 215 mm (8.5 in) from the nearest part of the lamp housing or heat-producing parts. The top edge of the sides of the test box shall be a minimum of 215 mm (8.5 in) above the highest point of any permanently attached part of the lamp housing.

19.15.3 The four sides of the test box shown in Figure 19.15.2 for a wall-mounted luminaire shall be a minimum distance of 215 mm (8.5 in) from the nearest part of the lamp housing. The depth of the box shall be 150 mm (6 in) or, if the luminaire is deeper, a dimension that provides contact with the back of the lamp housing.

19.15.4 Thermal insulation of the loose-fill type specified in Clause 19.16 shall be poured into the test box through the open top, until level with the top, without applying any compacting procedure.

**Figure 19.15.1**  
**Recessed luminaire test box, ceiling-mounted — Type IC (intended for thermal insulation contact) normal and abnormal temperature tests**

(See Clause 19.15.2.)



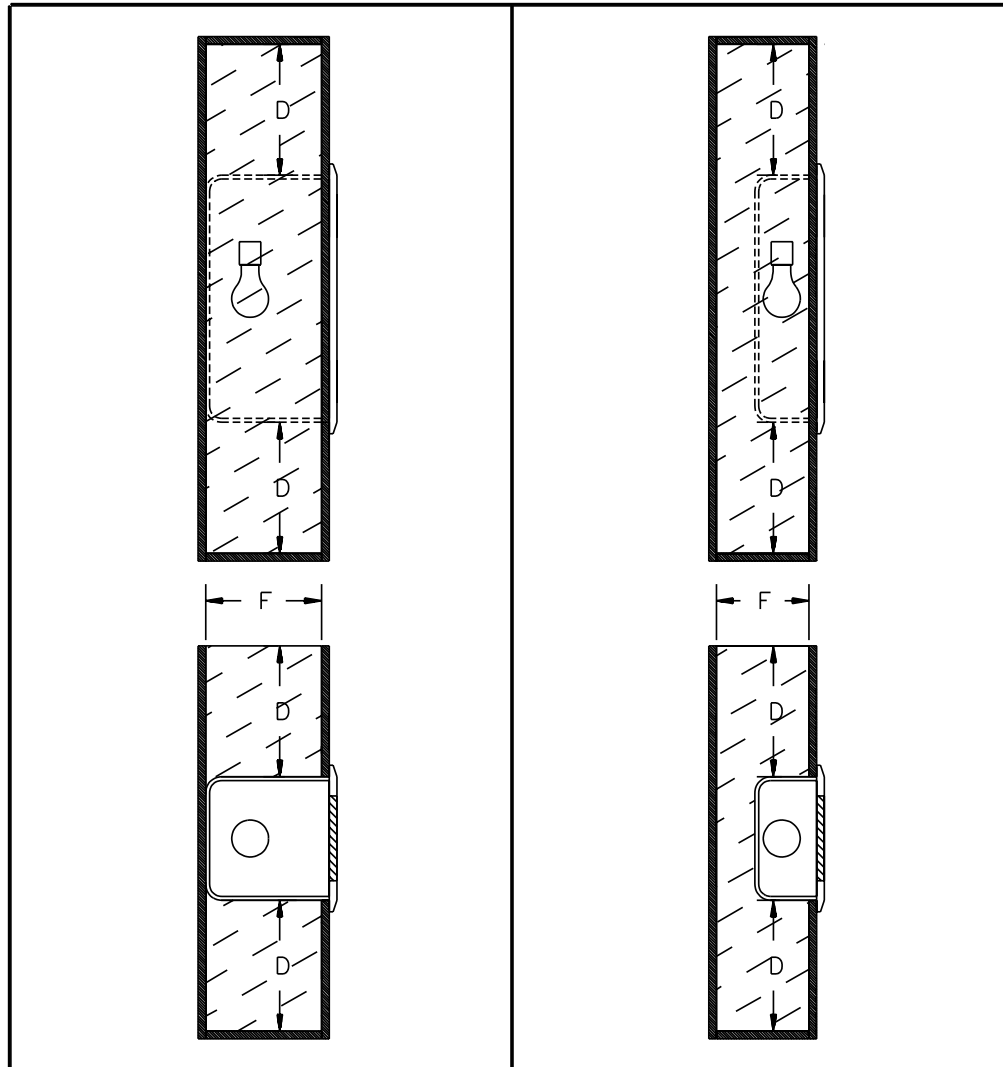
S3834A

NOTES

- (1) The upper drawing is a top view.
- (2) The lower drawing is a side section through the center of the top view.
- (3) Dimension D is 215 mm (8.5 in) from the nearest part of the lamp housing or other heat-producing parts.

**Figure 19.15.2**  
**Temperature test box for Type IC recessed wall-mounted luminaires (intended for thermal insulation contact)**

(See Clause 19.15.3.)



S3835A

**NOTES**

- (1) The upper drawing is a top view.
- (2) The lower drawing is a side section through the center of the top view.
- (3) Dimension D is 215 mm (8.5 in) minimum.
- (4) Dimension F is 150 mm (6 in) or, if the luminaire is deeper, the distance required to make contact with the back of the lamp housing.

**19.16 Thermal insulation used for recessed temperature tests**

19.16.1 Thermal insulation of the loose-fill type shall be conditioned to the density specified by the insulation manufacturer to obtain a required rated thermal resistance of Rsi 0.56 to 0.678 (R3.2 to R3.85).

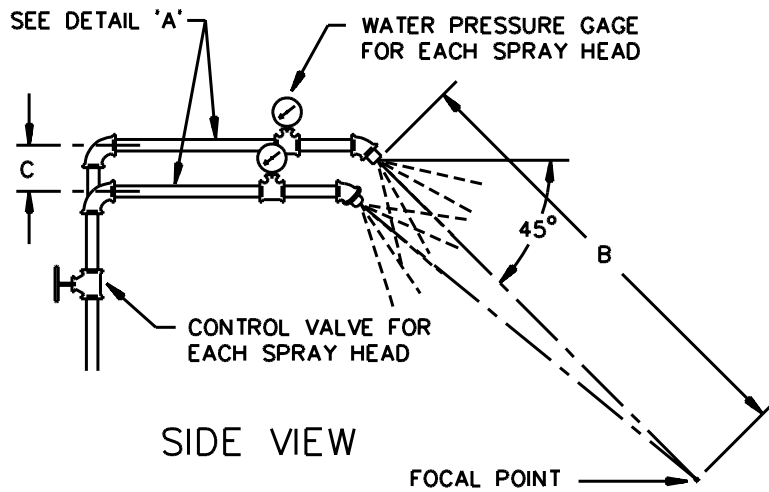
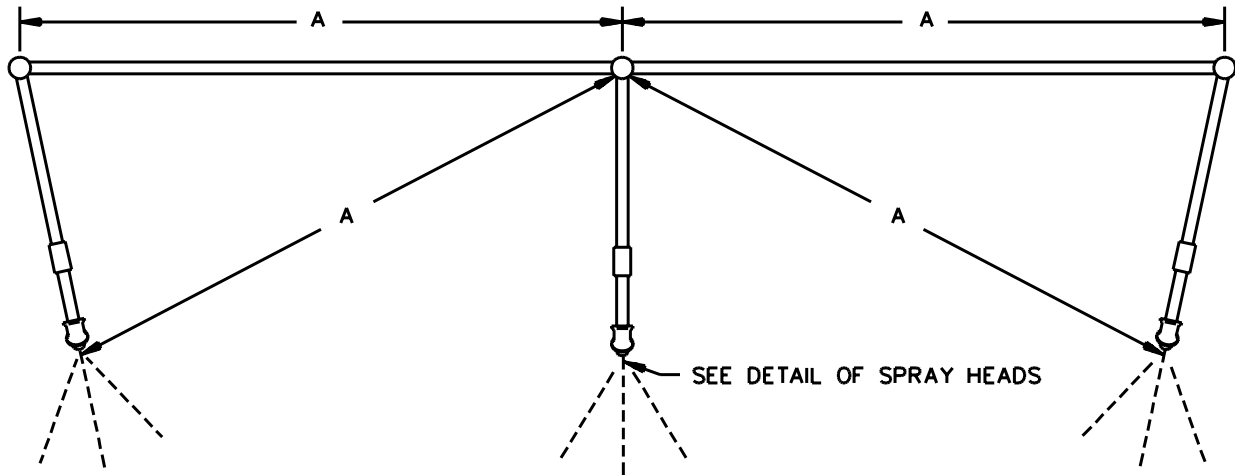
19.16.2 Thermal insulation shall be conditioned, if required, by a blowing or vacuum machine before it is placed around the test luminaire. Density shall be verified by placing insulation into a box of known volume and weight, and then weighing the filled box. The difference in weight between the empty and full box, divided by the volume, shall be the insulation density.

**19.17 Rain test apparatus**

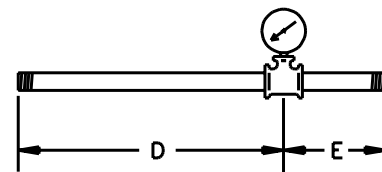
19.17.1 The rain test apparatus shall to consist of 3 spray heads mounted in a water supply pipe rack as shown in Figure 19.17.1. The spray heads shall be in accordance with Figure 19.17.2.

19.17.2 The water pressure shall be maintained at 34.5 kPa (5 psi) at each spray head.

**Figure 19.17.1**  
**Rain test apparatus**  
 (See Clause 19.17.1.)  
**PLAN VIEW**



**PIEZOMETER ASSEMBLY**  
**DETAIL 'A'**

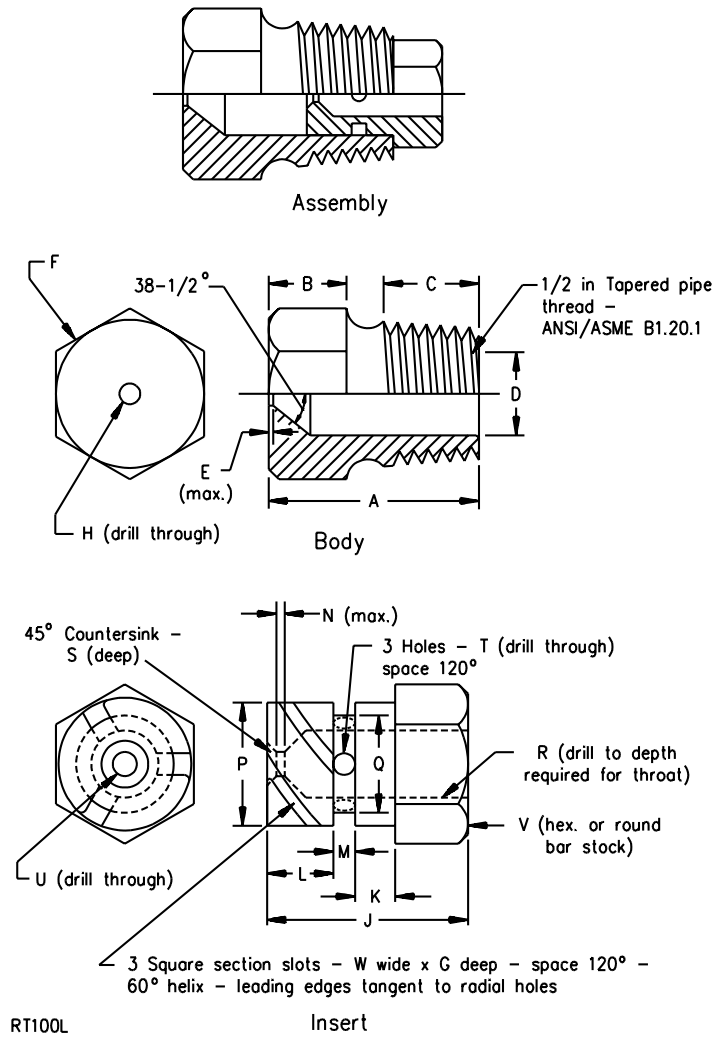


RT101B

Item	mm	(in)
A	710	(28)
B	1400	(55)
C	55	(2.25)
D	230	(9)
E	75	(3)

**Figure 19.17.2**  
**Spray head**

(See Clauses 19.17.1 and 19.18.1)



Item	mm	(in)	Item	mm	(in)
A	31.00	1.219	M	2.38	0.094
B	11.00	0.438	N	0.80	0.031
C	14.00	0.563	P	14.61 – 14.63	0.575 – 0.576
D	14.68 – 14.73	0.578– 0.580	Q	11.51 – 11.53	0.453 – 0.454
E	0.40	0.016	R	6.35	0.250
F	Optional	Optional	S	0.80	0.031
G	1.52	0.060	T	2.80	0.110
H	5.00	0.196	U	2.50	0.980
J	18.30	0.719	V	16.00	0.625
K	3.97	0.156	W	1.52	0.060
L	6.35	0.250			

**19.18 Sprinkler test apparatus**

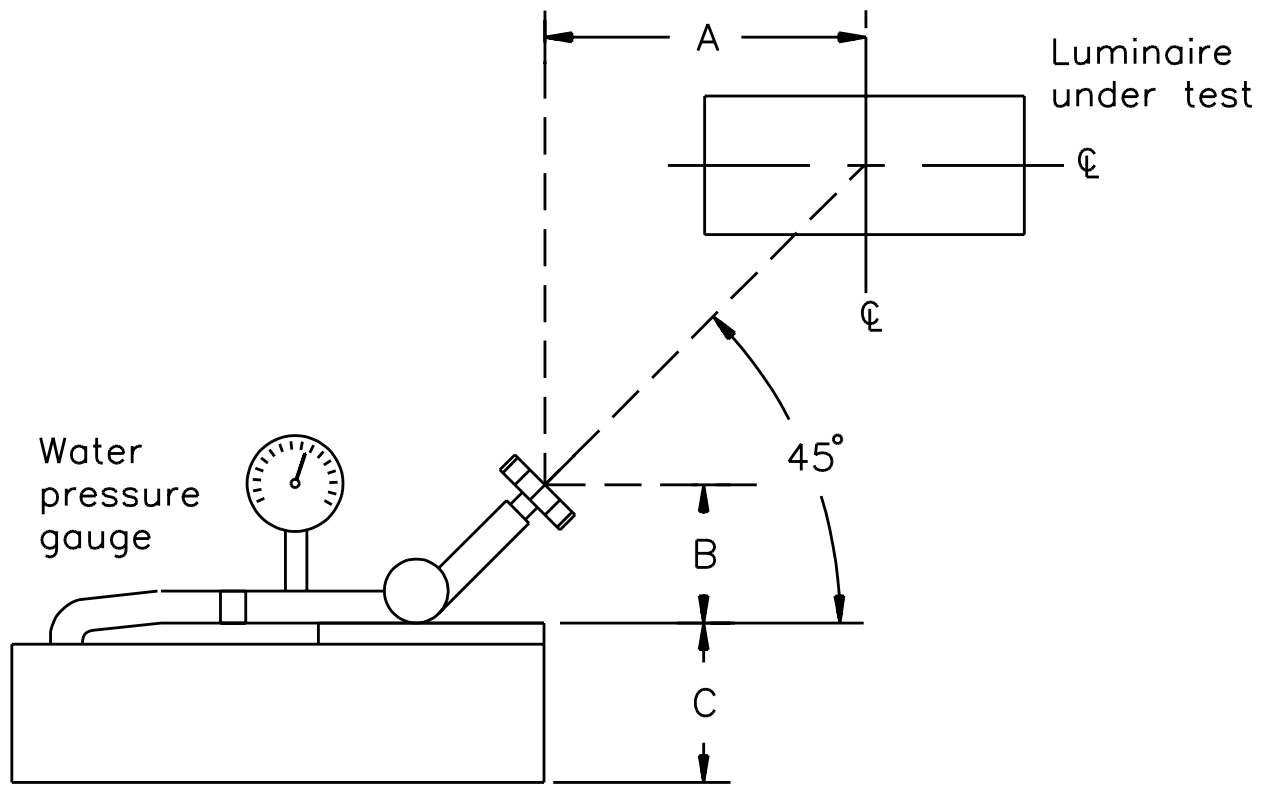
19.18.1 The sprinkler test apparatus shall consist of a single spray head mounted as shown in Figure

19.18.1. The spray head shall be in accordance with Figure 19.17.2.

19.18.2 The water pressure shall be maintained at 140 kPa (20 psi) at the spray head.

**Figure 19.18.1**  
**Sprinkler test apparatus**

(See Clause 19.18.1.)



S3807A

NOTES

(1) Dimension A is 915 mm (36 in).

(2) Dimension B is 75 to 150 mm (3 to 6 in).

(3) Dimension C is the height necessary for the luminaire to be mounted as intended with the dimensional center of the luminaire on a line projected from the centerline of the nozzle head.

## **19.19 Bond impedance and ground continuity test apparatus**

### **19.19.1 Bond impedance**

19.19.1.1 The bond impedance test apparatus shall consist of an indicating instrument and an ac or dc power supply of approximately 12 V providing a current of 30 A through the bonding means being evaluated.

### **19.19.2 Ground continuity**

19.19.2.1 The ground continuity test apparatus shall be an ohmmeter or similar indicating instrument capable of measuring 0.10  $\Omega$ .

## **19.20 Dielectric voltage-withstand test apparatus**

19.20.1 The dielectric voltage-withstand test apparatus shall include a 40 to 70 Hz transformer having an essentially sinusoidal output with a rating sufficient to maintain the required test potential and a means of indicating and regulating the output test potential. The sensitivity for the trip circuit shall be a maximum of 100 mA at the specified test voltage, and the equipment shall include an audible or visible indication of breakdown.

19.20.2 If the output of the test equipment is 500 VA or more, the test potential shall be indicated by a voltmeter in the primary circuit or in a tertiary winding circuit, by a selector switch marked to indicate the test potential, or by a marking in a readily visible location to indicate the test potential of equipment having a single test potential output. When a marking is used without an indicating voltmeter, the equipment shall include a positive means, such as a power-on lamp, to indicate that the manually reset switch has been reset following a tripout.

19.20.3 If the output of the test equipment is less than 500 VA, the equipment shall include a voltmeter in the output circuit to directly indicate the test potential.

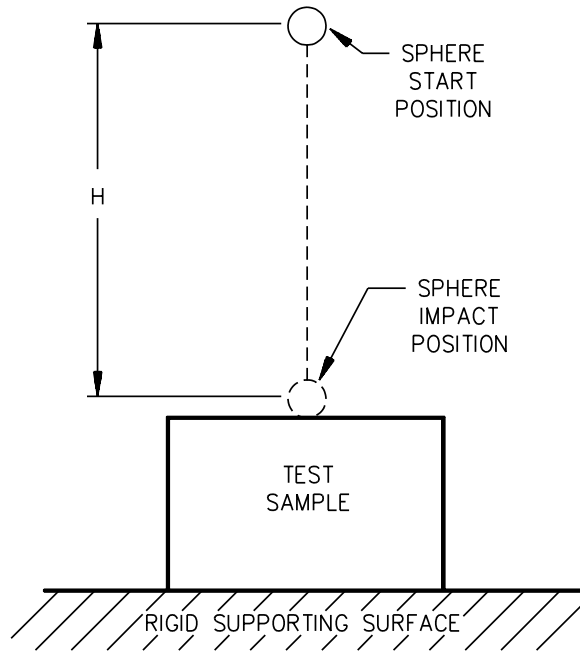
## **19.21 Impact test apparatus**

19.21.1 The impact shall be produced by dropping a steel sphere 51 mm (2 in) in diameter and weighing 0.54 kg (1.18 lb) from the height required to produce the desired impact force, as shown in Figure 19.21.1.

19.21.2 For surfaces other than horizontal, the steel sphere shall be suspended by a cord and shall swing as a pendulum through the vertical distance required to produce the required impact force, as shown in Figure 19.21.2.

**Figure 19.21.1**  
**Impact test apparatus horizontal surface**

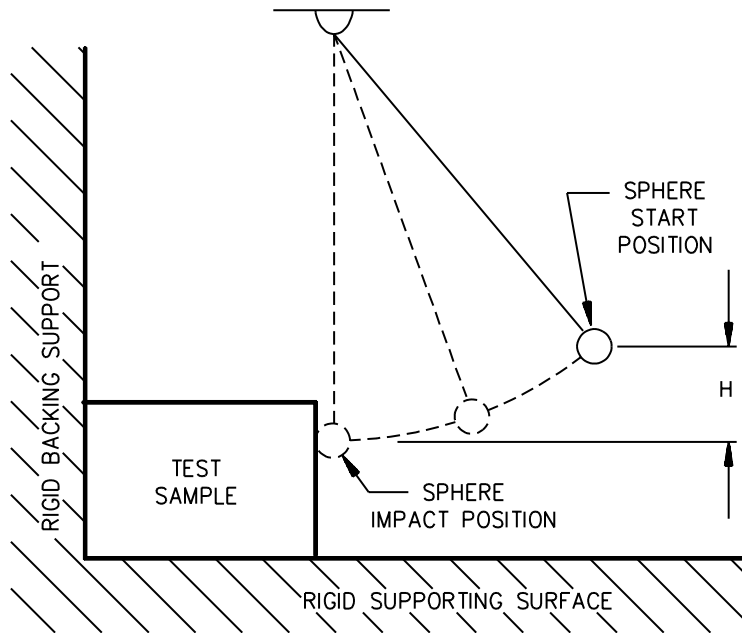
(See Clauses 16.5.7.2 and 19.21.1.)



S3836

**Figure 19.21.2**  
**Impact test apparatus vertical surface**

(See Clauses 16.5.7.2 and 19.21.2.)



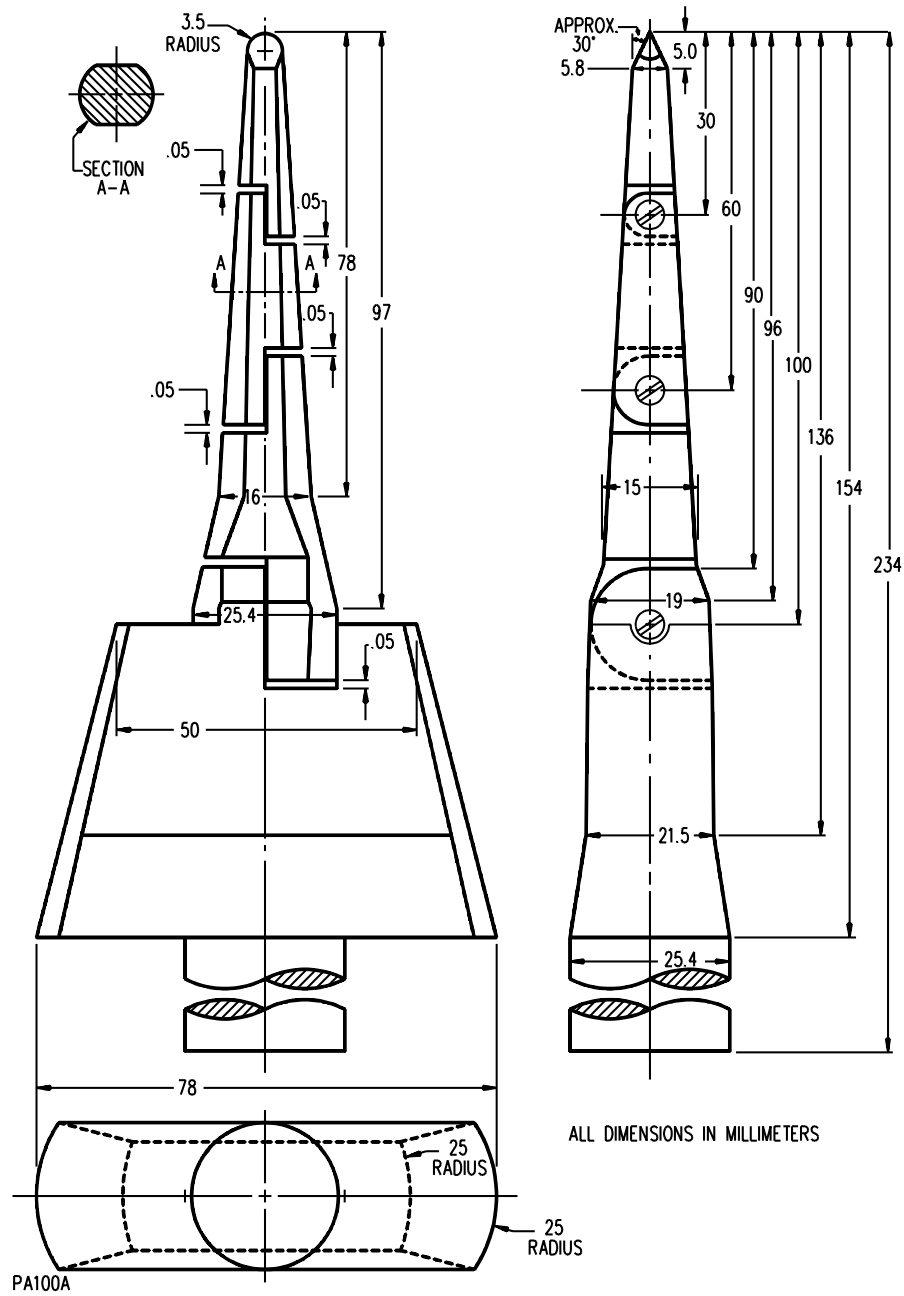
S3837

**19.22 Articulate probe**

19.22.1 The articulate probe shall be constructed in accordance with Figure 19.22.1.

**Figure 19.22.1**  
**Articulate probe with web stop**

(See Clause 19.22.1.)



NOTES

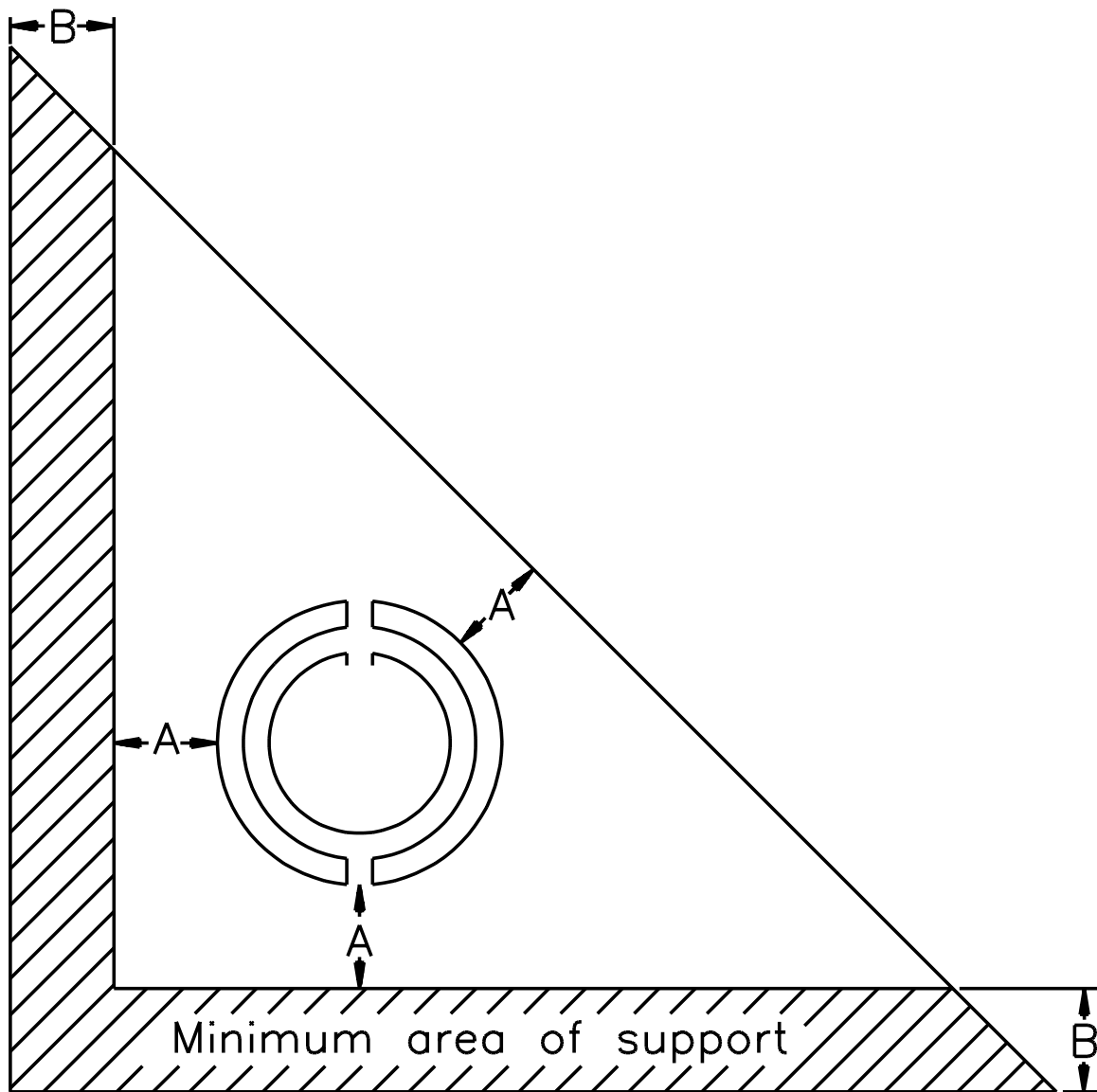
- (1) All dimensions are in millimeters
- (2) The articulate probe without the web stop may be used for openings having a minor dimension less than 19.1 mm (0.75 in).

### **19.23 Conduit knockout and twistout test apparatus**

19.23.1 A conduit knockout or twistout test plate shall be supported as shown in Figure 19.23.1.

**Figure 19.23.1**  
**Knockout and twistout test plate support apparatus**

(See Clause 19.23.1.)



S3838A

NOTES

- (1) The outer line indicates the test plate size.
- (2) Dimension A, the minimum dimension to the outside diameter of the knockout, is 13 mm (0.5 in).
- (3) Dimension B, the minimum area of support, is 13 mm (0.5 in).

#### 19.24 Five-inch flame test apparatus

19.24.1 The test apparatus shall be as shown Figure 19.24.1 and in accordance with ASTM D 5048.

19.24.1 (MEX) In Mexico, Clause 19.24.1 does not apply.

19.24.2 The burner shall be of the Bunsen or Tirrill type with a length of tube 89 to 101 mm (3.50 to 3.98 in) and an inside diameter of 9.5 to 11.1 mm (0.375 to 0.438 in).

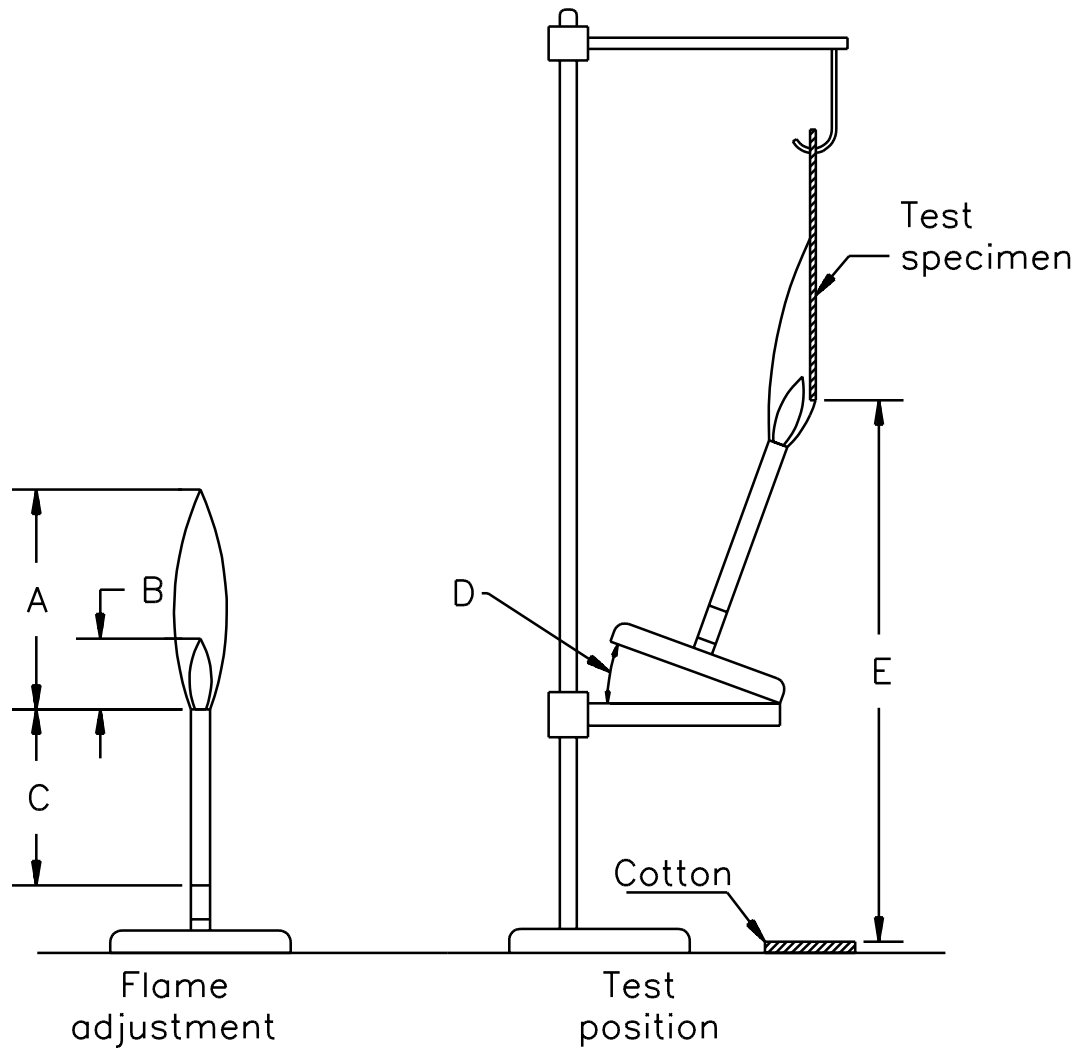
19.24.3 The burner shall be supported by a 20 degree angle block, and suitable guidance means shall be provided to allow the burner to be positioned repeatedly in the same position relative to the material under test.

19.24.4 The gas supply shall be of technical grade methane gas or natural gas having an energy density of approximately 37 MJ/m<sup>3</sup> (1000 btu/ft<sup>3</sup>).

19.24.5 A cotton indicator shall be placed approximately 300 mm (12 in) below the test specimen.

**Figure 19.24.1**  
**Five-inch flame test apparatus**

(See Clause 19.24.1.)



S3839A

NOTES

- (1) Dimension A, the flame height, is 125 mm (5 in) in the vertical position.
- (2) Dimension B, the inner flame cone height, is 40 mm (1.5 in).
- (3) Dimension C, the burner tube length, is 89 to 101 mm (3.50 to 4 in).
- (4) Dimension D, the burner base test mounting angle, is 20 degrees from the horizontal.
- (5) Dimension E, the cotton location, is 300 mm (12 in) directly below test specimen.

## 19.25 UV exposure test apparatus

19.25.1 The apparatus shall be in accordance with ASTM G 155-98.

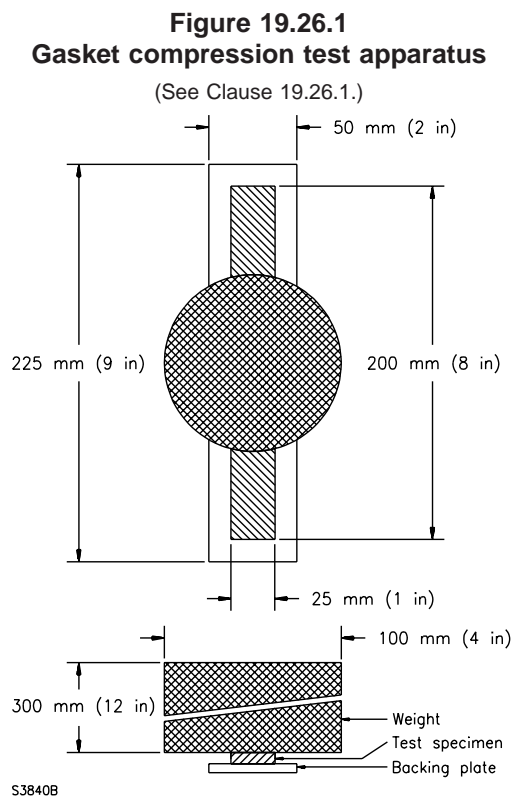
19.25.1 (MEX) In Mexico, the apparatus shall be in accordance with NMX-J-553-ANCE.

## 19.26 Gasket compression test apparatus

19.26.1 The test apparatus shall be as shown in Figure 19.26.1. The backing plate shall be galvanized or painted sheet steel, 50 mm (2 in) wide, 225 mm (9 in) long, and 1.6 to 3.5 mm (0.063 to 0.140 in) thick.

19.26.2 The test specimen shall be 25 mm (1 in) wide and 200 mm (8 in) long, and shall be attached to the backing plate by the manufacturer, using the proposed adhesive and production method.

19.26.3 The weight shall be a round steel bar 100 mm (4 in) in diameter, approximately 300 (12 in) long, weighing 18 kg (40 lb), and producing a pressure of 69 kPa (10 lbs/in<sup>2</sup>) on the test specimen.

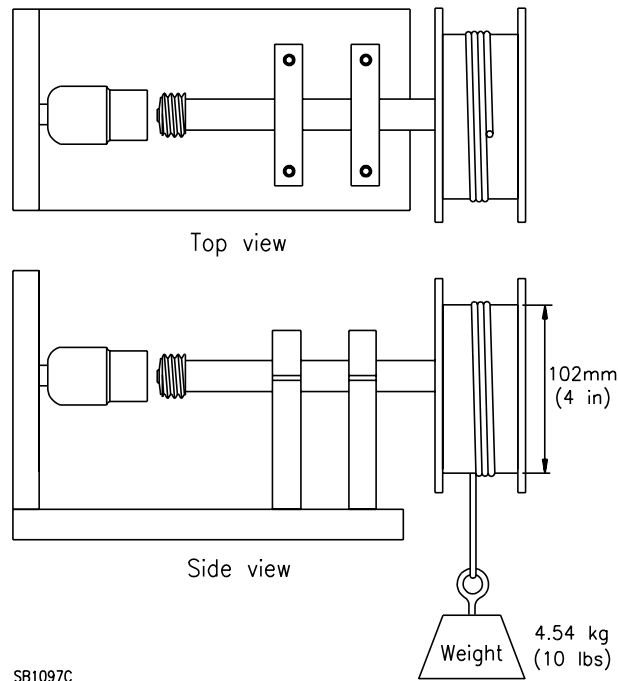


## 19.27 Lampholder mounting torque test apparatus

19.27.1 The test apparatus shall be as shown in Figure 19.27.1.

**Figure 19.27.1**  
**Medium-base lampholder mounting torsion test apparatus**

(See Clause 19.27.1.)



## 19.28 Glow-wire test apparatus

19.28.1 The description of the test apparatus shown in Figure 19.28.1 is an excerpt from IEC 60695-2-1. See the IEC publication for complete apparatus details and operation.

19.28.1 (MEX) In Mexico, the description of the test apparatus shown in Figure 19.28.1 is an excerpt from NMX-J-565/2-10-ANCE. See the ANCI publication for complete apparatus details and operation.

19.28.2 The glow-wire shall consist of a specified loop of a nickel/chromium (80/20) wire with a nominal diameter of 4 mm (0.16 in). The loop shall be formed so as to prevent fine cracking at the tip.

19.28.3 A sheathed fine-wire thermocouple, having an overall diameter of 0.5 mm (0.02 in) and wires of NiCr and NiAl, Type K, with the welded point located inside the sheath, shall be used for measuring the temperature of the glow-wire. The sheath shall consist of a metal resistant to the temperature of at least 960 °C. The thermocouple shall be arranged in a pocket hole, 0.6 mm (0.24 in) in diameter, drilled in the tip of the glow-wire.

19.28.4 The instrument for measuring the thermovoltage shall be capable of reading 1000 °C with an accuracy of 1 °C.

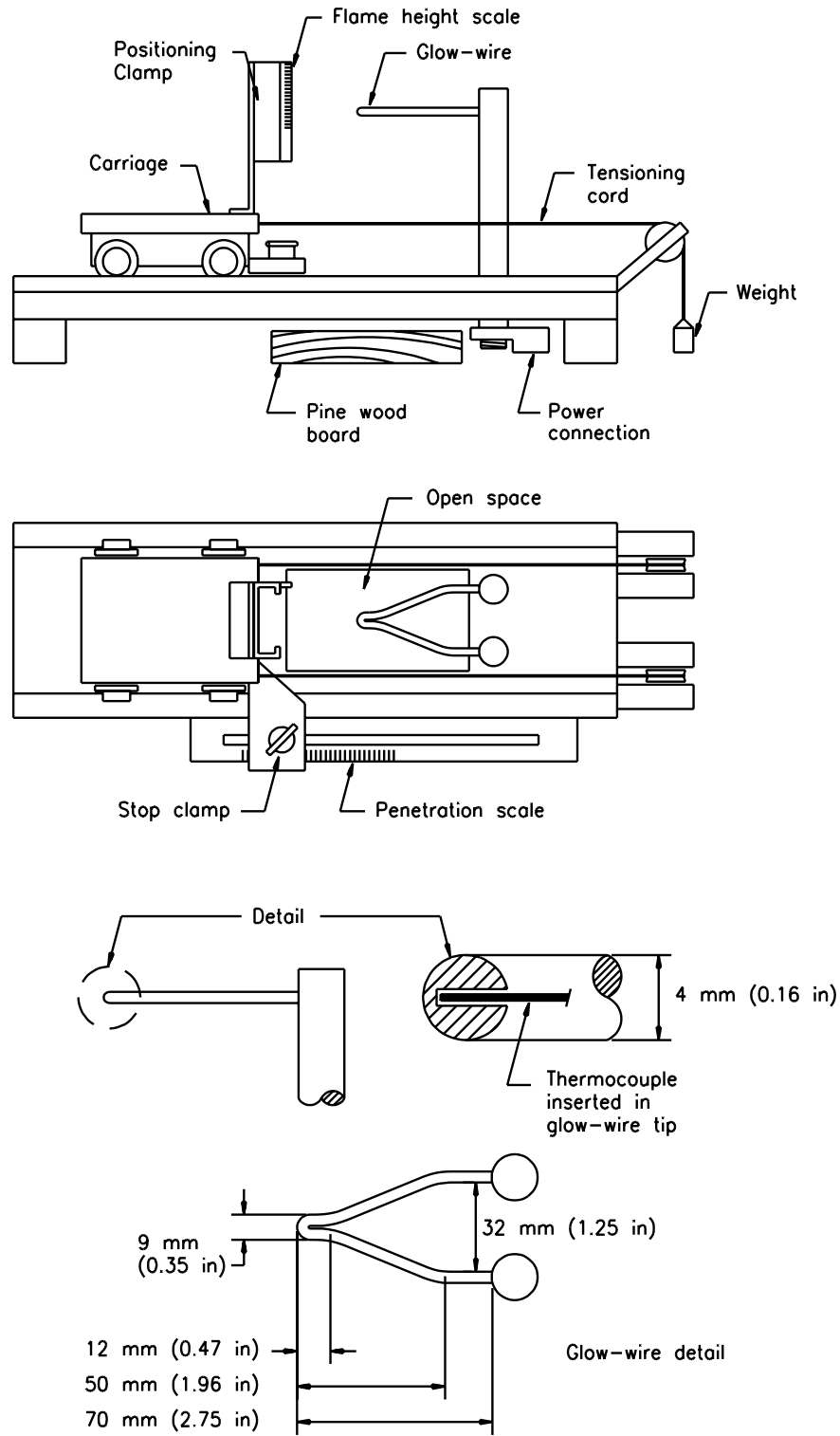
19.28.5 The glow-wire shall be electrically heated with a low-voltage transformer, and the current required to heat the tip to a temperature of 960 °C shall be between 120 and 150 A. A voltage adjustment method shall be provided to allow continuous adjustment of the power level to achieve the desired glow-wire tip temperature.

19.28.6 The positioning clamp shall be designed to support the test specimen and apply the glow-wire to the specimen in a horizontal plane with a force of 0.8 to 1.2 N (0.18 to 0.27 lb). The force shall be maintained at this value when either the glow-wire or the specimen is moved horizontally towards the other. The mechanism shall allow at least 7 mm (0.275 in) penetration of the glow-wire into the specimen, and a stop mechanism shall be provided to mechanically limit penetration to a distance of 7 mm (0.275 in).

19.28.7 To evaluate of the risk of spread of fire or of falling glowing particles from the specimen, a piece of flat, smooth, white pine wood board, approximately 10 mm (0.4 in) thick and covered with a single layer of tissue paper, in loose contact, shall be located at a distance of  $200 \pm 5$  mm ( $7.8 \pm 0.2$  in) below the glow-wire. The tissue paper shall be undyed, soft, strong, and lightweight, weighing between 12 and 30 gm/m<sup>2</sup> (0.004 and 0.009 oz/ft<sup>2</sup>).

**Figure 19.28.1**  
**Glow-wire test apparatus**

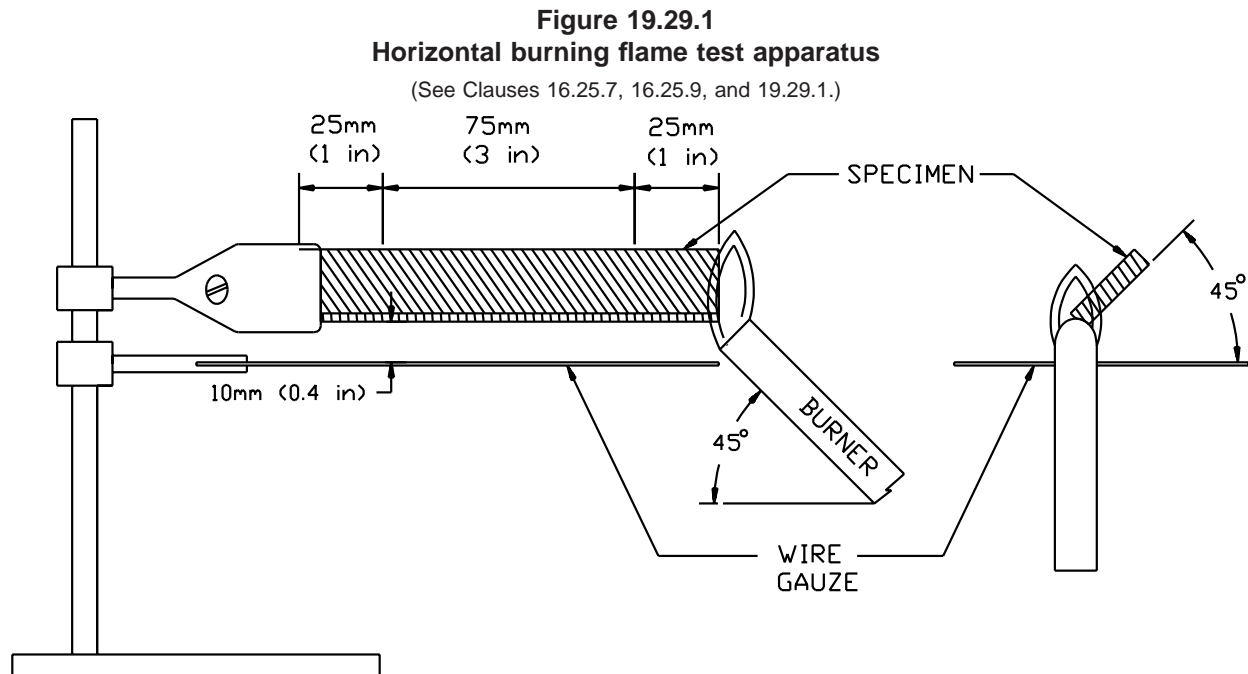
(See Clauses 16.7.6 and 19.28.1.)



S3841A

## 19.29 Horizontal burning flame test apparatus

19.29.1 The test apparatus shall be as shown in Figure 19.29.1 and in accordance with ASTM D 635.



S3842

19.29.1 (MEX) In Mexico, the test apparatus shall be as shown in Figure 19.29.1 and in accordance with NMX-J-307-ANCE.

## 19.30 Vertical burning flame test apparatus

19.30.1 The test apparatus shall be as shown in Figure 19.30.1 and in accordance with ASTM D 3801.

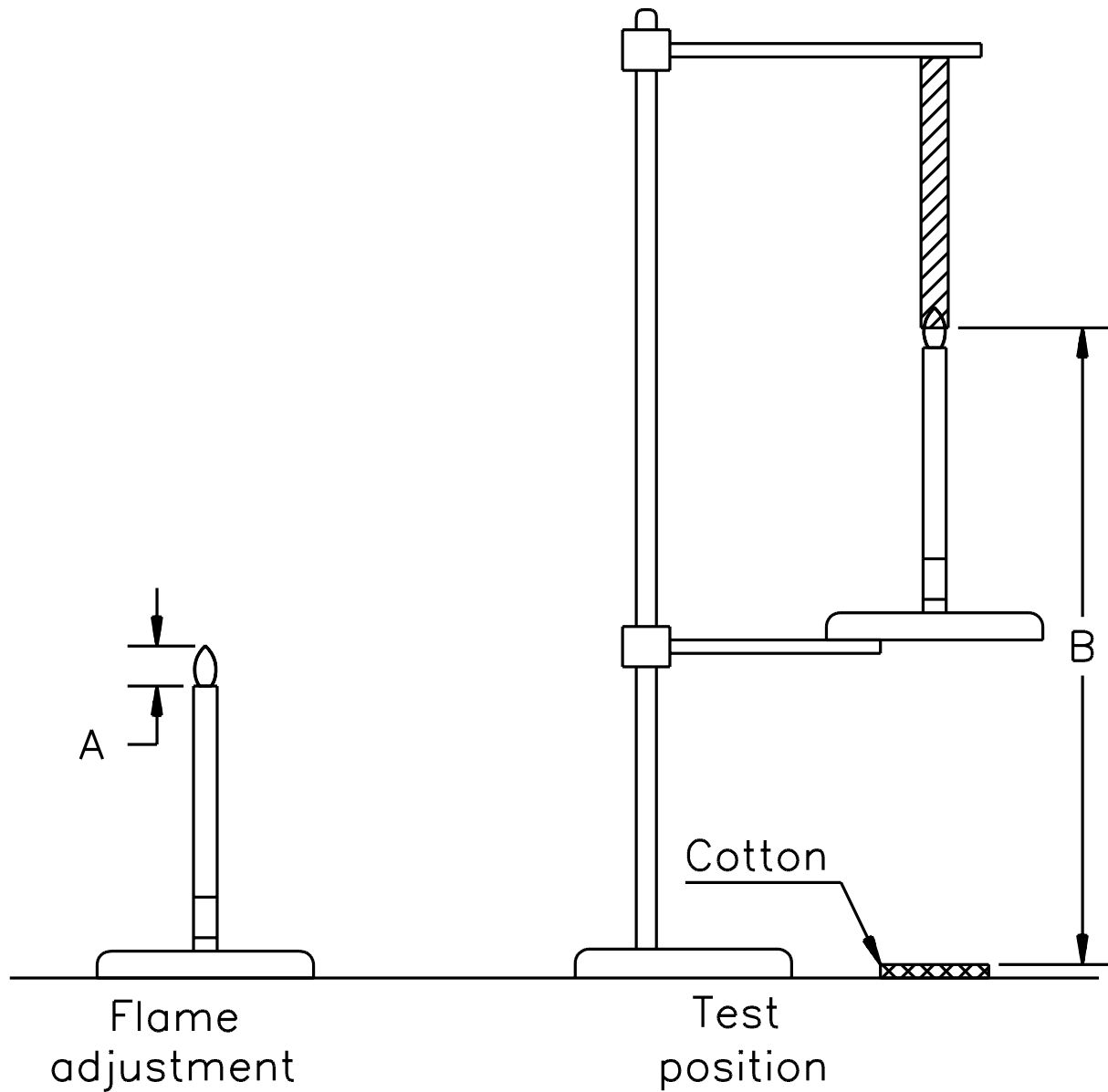
19.30.1 (MEX) In Mexico, Clause 19.30 does not apply.

19.30.2 The burner shall be of the Bunsen or Tirrill type with a length of tube 89 to 101 mm (3.50 to 3.98 in) and an inside diameter of 9.5 to 11.1 mm (0.375 to 0.438 in). The tube shall not be equipped with stabilizers and other end attachments.

19.30.3 The gas supply shall be of technical grade methane gas or natural gas having an energy density of approximately 37 MJ/m<sup>3</sup> (1000 btu/ft<sup>3</sup>).

**Figure 19.30.1**  
**Vertical burning flame test apparatus**

(See Clauses 16.26.5 and 19.30.1.)



S3843A

NOTES

(1) Dimension A, the flame height, is 19 mm (0.75 in) in the vertical position.

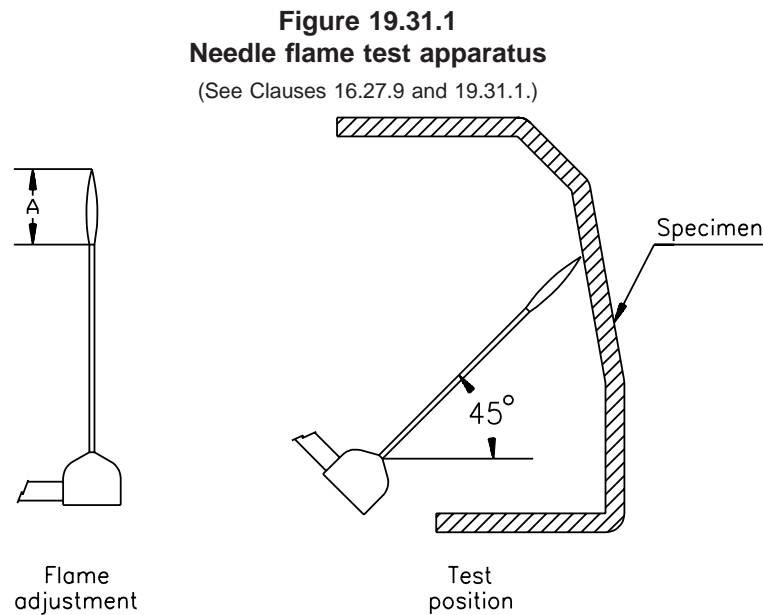
(2) Dimension B, the distance from the cotton location to the test specimen, is 300 mm (12 in).

### 19.31 Needle flame test apparatus

19.31.1 The test apparatus shall be in accordance with Figure 19.31.1.

19.31.2 The burner to produce the test flame shall consist of a tube that is at least 35 mm (1.38 in) long and that has a bore of 0.4 to 0.6 mm (0.016 to 0.024 in) and an outer diameter not exceeding 0.9 mm (0.035 in). A hypodermic needle, with the tapered end cut off, may be used for the test apparatus.

19.31.3 The burner shall be supplied with butane or propane gas having a purity of at least 95 percent. There shall be no air admitted to the burner tube.



NOTE: Dimension A, flame height, is 11 to 13 mm (0.43 to 0.5 in) in the vertical position.

### 19.32 Plywood test box material

19.32.1 The plywood used for constructing temperature test boxes shall be 12 mm (0.5 in) thick, with at least one side that has all voids filled and sanded.

**19.33 (MEX) Insulation resistance test apparatus**

19.33.1 (MEX) In Mexico, insulation resistance measurements shall be made using a 500 V dc insulation tester or other suitable equipment. For safety reasons, the test shall be performed with the luminaire disconnected from the power supply and away from the rain test apparatus.

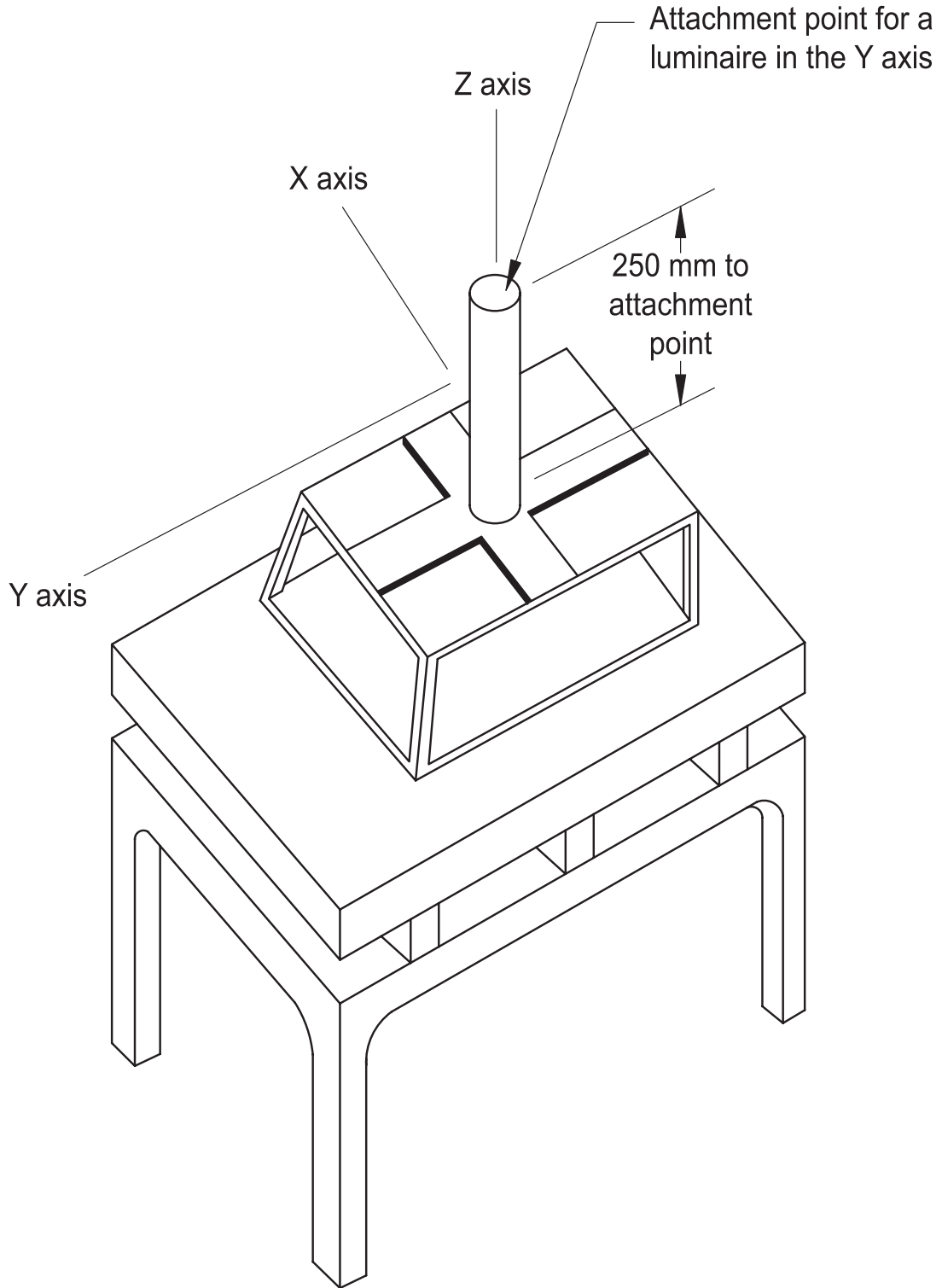
**19.34 (MEX) Vibration test apparatus**

19.34.1 (MEX) In Mexico, the following equipment shall be used for vibration testing:

- (a) vibration table (Figure 19.34.1 (MEX)),
- (b) mounting arm, and
- (c) chronometer.

**Figure 19.34.1 (MEX)**  
**Vibration table**

(See Clause 19.34.1 (MEX).)



su0112

## 20 Marking

### 20.1 General

20.1.1 A luminaire shall be legibly marked using one or more of the following methods in accordance with Table 20.1.1:

- (a) lettering on a pressure-sensitive label;
- (b) paint stencilled lettering;
- (c) ink-stamped machine lettering;
- (d) ink-hand-stamped lettering;
- (e) indelibly printed lettering;
- (f) die-stamped lettering;
- (g) embossed lettering;
- (h) molded or cast lettering; and
- (i) etched lettering in metal.

20.1.2 A pictogram in accordance with Annex D may be used as a substitute for the corresponding text of Table 20.1.1, and shall be the subject of special investigation.

20.1.3 A marking shall be of the minimum size (S\_\_) and in the location (L\_\_) shown in the "Format" column of Table 20.1.1 and as defined in Tables 20.1.2 and 20.1.3.

20.1.4 "Verbatim" in the "Text" column of Table 20.1.1 indicates that the marking shall consist of only the exact words shown or a marking including these words and conveying the original intent. Alternative wording for other markings in the Table may be used, subject to evaluation.

20.1.5 The characters of embossed, molded, or cast lettering, either in or out, shall be a minimum of 0.25 mm (0.010 in) in depth.

20.1.6 When a permanent-type label (Type P) is required in accordance with Table 20.1.3, paint stencilled, ink-stamped, and indelibly printed lettering shall be legible as determined by the test of Clause 20.3. The stamping device shall provide consistent and even pressure, regardless of the operator.

20.1.7 Pressure-sensitive labels and nameplates of the permanent type (Type P) that are secured by adhesive shall be in accordance with CSA C22.2 No. 0.15 or UL 969.

20.1.7 (MEX) In Mexico, Clause 20.1.7 does not apply.

20.1.8 The adhesive of pressure-sensitive labels and nameplates of the permanent type (Type P) shall be suitable for the mounting surface, temperature, and environment.

## 20.2 Identification and ratings

20.2.1 A luminaire shall be marked with the following:

- (a) manufacturer's identification, in accordance with Table 20.1.1, Item 4.1;
- (b) date code of at least the month and year of manufacture, in accordance with Table 20.1.1, Item 4.3;
- (c) factory identification, if more than one location, in accordance with Table 20.1.1, Item 4.6; and
- (d) other markings, as required.

20.2.2 A luminaire shall be marked with catalogue number, model number, series number, or other similar designation in accordance with Table 20.1.1, Item 4.2.

20.2.3 A luminaire that employs a ballast or transformer shall be marked with the input rating in volts, hertz, and total amperes or watts, in accordance with Table 20.1.1, Item 1.3, unless:

- (a) the required marking is shown on the ballast or transformer, and is visible during installation and inspection of wire connections; or
- (b) the luminaire is intended for use with a remote ballast or transformer.

20.2.4 Where parts of a luminaire, except for lenses, diffusers, and decorative parts, are shipped in more than one package, each package shall be marked with the following:

- (a) the manufacturer's identification, in accordance with Table 20.1.1, Item 4.1; and
- (b) part numbers, group numbers, descriptive designation, or other identification, in accordance with Table 20.1.1, Item 1.8.

20.2.5 (CAN) In Canada, bilingual marking is the jurisdiction of Canadian provincial regulatory authorities, which may require marking to also be in French, as shown in Annex B.

20.2.5 (MEX) In Mexico, all markings shall be in Spanish.

### 20.3 Durability of stamped ink marking test

20.3.1 Stamped ink markings shall be dried at room temperature for at least 5 d, after which they shall be given one wipe with a cloth dampened with water, and then a second wipe with a cloth dampened with mineral spirits, without becoming illegible.

### 20.4 Luminaire mounting and orientation

20.4.1 When the mounting position of a luminaire is not visually evident and it is required to be mounted or oriented in a particular position to comply with this Standard, a marking shall be provided to instruct the installer, in accordance with Table 20.1.1, Item 2.13.

20.4.2 A luminaire that has a mounting surface temperature of more than 90 °C, but not more than 150 °C, during the normal temperature test shall be marked for installation on a noncombustible surface only, in accordance with Table 20.1.1, Item 2.6.

### 20.5 Wiring instructions

20.5.1 Wiring instructions that specify the proper method of connecting the grounding means and maintaining polarity shall be included with the luminaire in a manner that will require the installer to handle the instructions during installation, or the luminaire carton shall be marked to require installation by a person familiar with the construction and operation of the product and the hazards involved, in accordance with Table 20.1.1, Item 1.31.

### 20.6 (MEX) Marking requirements in Mexico

#### 20.6.1 (MEX) General

20.6.1.1 (MEX) In Mexico, markings and labels on luminaires, instruction sheets, and cartons shall meet the requirements of Clauses 20.6.2 (MEX), 20.6.3 (MEX), and 20.6.4 (MEX), as applicable.

20.6.1.2 (MEX) In Mexico, markings and labels on luminaires, instruction sheets, and cartons shall meet the following requirements:

- (a) the use of a period as decimal point shall not be allowed. A comma shall be used as a decimal point.
- (b) magnitudes less than the unit shall be represented with a zero followed by #, where # equals magnitude (for example, 90 cm = 0.90 m).
- (c) letter size shall not apply to any marking.
- (d) where applicable, input voltages (V) and current symbols shall be
  - (1) c.a. instead of AC; or
  - (2) c.d. instead of DC; and
  - (3) ~.

## 20.6.2 (MEX) Luminaires

20.6.2.1 (MEX) In Mexico, luminaires shall be marked with the following:

- (a) the name or trademark, model, or manner in which the manufacturer or importer identifies the product;
- (b) the maximum wattage in watts and maximum current in amperes;
- (c) the nominal frequency (Hz), when the frequency is different from 60 Hz;
- (d) the type and lamp wattage in watts;
- (e) a statement that identifies the origin of the product;
- (f) the following statement in accordance with Table C.1 (MEX), Item 1.43: PARA CONEXIONES DE ALIMENTACION UTILICE CONDUCTORES ADECUADOS PARA: XX °C the temperature in accordance with Table 20.6.2.1 (MEX);
- (g) the following statement for indoor luminaires only: TEMPERATURA AMBIENTE MAXIMA DE OPERACION: XX °C, in accordance with Table 20.6.2.1 (MEX) and Table C.1 (MEX), Item 2.32.

**Table 20.6.2.1 (MEX)**  
**Marking for temperature at possible points of contact**

(See Clause 20.6.2 (MEX).)

Temperature at the points of possible contact of the supply conductors and the luminaire, °C	Temperature to be marked on the luminaire, °C
60 or less	60
61 – 75	75
76 – 90	90
91 – 105	105
106 – 125	125
126 – 155	155
156 – 200	200

NOTE These values include the ambient temperature.

### 20.6.3 (MEX) Instruction sheets

20.6.3.1 (MEX) In Mexico, instruction sheets shall include the following:

- (a) a sentence that invites the customer to read the instruction sheet;
- (b) the national manufacturer's or importer's name, address, telephone number, and telefax number;
- (c) the name or trademark, model, or manner in which the manufacturer or importer identifies the product;
- (d) electrical connection instructions for the appropriate function of the luminaire; and
- (e) nominal electrical input features of the luminaire according to Clause 20.6.2 (MEX).

### 20.6.4 (MEX) Cartons

20.6.4.1 (MEX) In Mexico, cartons shall include the following markings:

- (a) a graphic representation or product name, except when it is obvious;
- (b) the national manufacturer's or importer's name, address, telephone number, and telefax number;
- (c) a statement that identifies the origin of the product;
- (d) the type and lamp wattage;
- (e) the following electrical characteristics
  - (1) nominal input voltage(s) and symbol;
  - (2) maximum wattage in watts or maximum current in amperes; and
  - (3) nominal frequency (Hz) when the frequency is different from 60 Hz;
- (f) the number of pieces per carton.

**Table 20.1.1**  
**List of required markings**

Item	Installation instructions	Text	Format	Clause reference
1.1	MIN ___ °C SUPPLY CONDUCTORS	Verbatim	S24-L3 and S32-L4	6.7.2.4 6.15.1.5 6.15.1.5 (CAN) 7.2.3.2 7.2.3.3 7.2.3.4 7.2.3.5 8.5.2 10.6.9 (USA) 10.6.9 (CAN) 10.6.10 (CAN) 11.8.1.2 12.3.4.1
1.2	CONNECT TO BRANCH CIRCUIT RATED ___ AMPS MAX		S24-L3	11.8.1.8 11.8.1.9
1.3	___ VOLTS ___ AMPS ___ WATTS ___ HERTZ or ___ V ___ A ___ W ___ HZ		S24-L3	20.2.3
1.4	___ VOLTS ___ HERTZ or ___ V ___ HZ		S24-L3	6.2.2 7.1.4
1.5	N or NEUTRAL or W or WHITE		S24-L3	6.10.1
1.6	SUITABLE FOR OPERATION IN AMBIENT NOT EXCEEDING ___ °C		S24-L2	12.4.3.1
1.7	SUITABLE FOR USE AS A RACEWAY		S24-L3	5.20.3
1.8	ASSEMBLE PART [Catalogue Number] ONLY WITH PART [Catalogue Number]		S24-L4	5.2.3 20.2.4
1.9	USE ONLY WITH [Manufacturer] [Catalogue Number] TRIMS		S24-L2	11.8.1.7
1.10	USE ONLY WITH [Manufacturer] [Catalogue Number] LUMINAIRE		S24-L2	11.7.1.8 (USA) 12.2.4.4 (USA)
1.11	USE WITH LISTED LIGHT DIFFUSER		S24-L2	12.2.4.3 (USA)
1.12	PROPRIETARY WIRING SYSTEM [Name, Part Number, Cautionary Marking]		S24-L2	6.15.1.1
1.13	DO NOT INSTALL INSULATION WITHIN 76 mm (3 in) OF ANY PART OF THE LUMINAIRE		S24-L2	11.8.1.10 11.8.4.1
1.14	VAPOR BARRIER MUST BE SUITABLE FOR 90 °C		S24-L2	11.8.1.12 11.8.1.12 (USA)
1.15	SUITABLE FOR AIR-HANDLING USE		S24-L2	12.2.4.1
1.16	VENTILATING OR COOLED AIR ONLY		S24-L2	12.2.4.2
1.17	INSTALL ONLY IN ENVIRONMENTAL AIR- HANDLING SPACES WHERE A COMPLETE METAL-ENCLOSED WIRING SYSTEM IS PROVIDED		S24-L3	12.2.4.7
1.18	ONLY FOR USE IN ENVIRONMENTAL AIR- HANDLING SPACES OTHER THAN DUCTS OR PLENUMS OR WHEN ATTACHED TO PARTS THAT COVER VENT OPENINGS IN ACCORDANCE WITH THE CEILING FIRE-RATING SPECIFICATION		S24-L2	12.2.4.6
1.19	INSTALL WITH MINIMUM SPACINGS BETWEEN (a) CENTER-TO-CENTER OF ADJACENT LUMINAIRES: ___ mm (___ in); (b) TOP OF LUMINAIRE TO OVERHEAD BUILDING MEMBER: ___ mm (___ in); (c) LUMINAIRE CENTER TO SIDE BUILDING MEMBER: ___ mm (___ in).		S24-L2	11.7.1.11 11.8.3.1 12.3.4.2

Table 20.1.1 Continued on Next Page

Table 20.1.1 Continued

Item	Installation instructions	Text	Format	Clause reference
1.20	INSTALL PHOTOCONTROL OR SHORTING PLUG		S24-L2	6.4.1.5
1.21	THIS LUMINAIRE MUST BE MOUNTED OR SUPPORTED INDEPENDENTLY OF AN OUTLET BOX		S24-L2	10.2.5 10.2.5 (USA)
1.22	FOR CHAIN OR HOOK SUSPENSION ONLY		S24-L2	10.8.4
1.23	LIMIT RANGE OF ADJUSTMENT TO [Instruction]		S24-L1	13.4.9.2
1.24	FOR USE ONLY WITH A LUMINAIRE WITH INTEGRAL SUPPLY CONDUCTOR SUPPORT		S24-L2	10.3.9
1.25	PUSH CONDUCTORS INTO JUNCTION BOX		S24-L2	7.2.7.2
1.26	FOR USE IN NON-FIRE-RATED INSTALLATIONS ONLY		S24-L2	11.4.7 11.8.5.2
1.27	FOR LINE VOLTS-AMPERES MULTIPLY TOTAL LAMP WATTAGE BY 1.5		S24-L3	8.6.1
1.28	FOR LINE VOLTS-AMPERES MULTIPLY TOTAL LAMP WATTAGE BY 2.5		S24-L3	8.6.1
1.29	FOR LINE VOLTS-AMPERES MULTIPLY TOTAL LENGTH OF ALL LAMPS IN INCHES BY ____		S24-L3	8.6.1
1.30	USE THERMALLY PROTECTED BALLAST FOR TYPE ____ LAMPS		S24-L2	8.6.3
1.31	THIS PRODUCT MUST BE INSTALLED IN ACCORDANCE WITH THE APPLICABLE INSTALLATION CODE BY A PERSON FAMILIAR WITH THE CONSTRUCTION AND OPERATION OF THE PRODUCT AND THE HAZARDS INVOLVED		S24-L4	10.8.1 20.5.1
1.32	CONSULT A QUALIFIED ELECTRICIAN TO ENSURE CORRECT BRANCH CIRCUIT CONDUCTOR		S24-L4	10.8.1 10.8.1 (CAN)
1.33	INSTALLATION OR ASSEMBLY INSTRUCTIONS		S16-L5	5.1.2 5.2.2 5.15.2.4 5.15.2.5 6.14.1.3 6.14.2.13 6.15.1.1 6.15.1.3 7.3.1.2 10.2.5 10.2.5 (USA) 10.2.6 10.6.7 (USA) 11.1.4 11.8.4.1 11.8.5.1 13.4.9.3
1.34	ROUGH-IN SECTION FOR USE WITH FINISHING SECTION ____		S16-L2	11.8.1.5
1.35	FINISHING-SECTION FOR USE WITH ROUGH-IN SECTION ____		S16-L2	11.8.4.1
1.36	ROUGH-IN SECTION ____ FOR CONVERTIBLE RECESSED LUMINAIRE		S16-L2	11.8.4.1
1.37	FOR CABLE USE ONLY — NOT FOR PULLING WIRES		S24-L3	11.3.3

Table 20.1.1 Continued

Item	Installation instructions	Text	Format	Clause reference
1.38	TYPE-IC TRIMS/FINISHING SECTIONS: AA BB CC [etc.] TYPE NON-IC TRIMS/FINISHING SECTIONS: AA BB CC [etc.]		S24-L3	11.8.4.1
1.39	FOR USE IN ONE- AND TWO-FAMILY DWELLINGS ONLY or NOT FOR USE IN ENVIRONMENTAL AIR-HANDLING SPACES		S24-L3	11.8.5.2
1.40	MAXIMUM OF ____ AWG THROUGH BRANCH CIRCUIT CONDUCTOR SUITABLE FOR ____ °C PERMITTED IN BOX		S24-L3	11.3.3 14.10.3 14.11.2
1.41	USE BALLAST FOR ____ WATT ____ TYPE LAMP		S24-L2	6.7.2.3
1.42	THIS LUMINAIRE IS PROVIDED WITH A FACTORY- INSTALLED EMERGENCY LIGHTING BATTERY PACK		S24-L2	8.7
1.43	FOR INSTALLATION USE SUPPLY CONDUCTORS RATED ____ °C	Verbatim	S24-L3	20.6.2 (MEX)
1.44	IMPORTANT SAFETY INSTRUCTIONS	Verbatim	S24-L5	8.10.2 (CAN)
Item	Mounting locations	Text	Format	Clause reference
2.1	DRY LOCATIONS ONLY	Verbatim	S24-L2	13.1.2
2.2	SUITABLE FOR DAMP LOCATIONS	Verbatim	S24-L2	13.1.2 13.3.1.1
2.3	SUITABLE FOR WET LOCATIONS	Verbatim	S24-L2	13.1.2 13.4.9.1
2.4	OUTDOOR USE ONLY	Verbatim	S24-L2	8.2.1
2.5	NOT FOR USE IN DWELLINGS	Verbatim	S24-L3	6.7.1.1 6.15.1.4 7.2.3.2 10.6.9 (USA) 10.6.9 (CAN) 10.6.10 (CAN) 11.8.1.2
2.6	NONCOMBUSTIBLE SURFACE ONLY	Verbatim	S24-L3	10.4.9 10.8.3 11.7.1.10 20.4.2
2.7	ACCESS ABOVE CEILING REQUIRED	Verbatim	S24-L2	11.6.1.1 11.8.1.4
2.8	ACCESS BEHIND WALL REQUIRED	Verbatim	S24-L2	11.8.1.4
2.9	FOR NONCOMBUSTIBLE CEILING PLENUM ONLY		S24-L2	12.2.4.5
2.10	WALL MOUNT ONLY	Verbatim	S24-L2	7.2.7.1 10.7.2 14.2.1
2.11	COVERED CEILING MOUNT ONLY		S24-L2	13.4.8.3 13.4.8.6
2.12	SUITABLE FOR UNDER-CABINET MOUNT	Verbatim	S24-L2	10.8.2 (USA)
2.13	MOUNTING ORIENTATION – (Such as this end up)		S24-L2	20.4.1
2.14	SUITABLE FOR GROUND-MOUNTED RECESSED		S24-L2	13.4.8.13
2.15	RESERVED			
2.16	SUITABLE FOR CONTINUOUS ROW MOUNTING		S24-L2	5.19.1
2.17	INSTALL IN BUILDINGS OF FIRE-RESISTIVE CONSTRUCTION – MOUNT ON NONCOMBUSTIBLE MATERIAL		S24-L2	11.8.1.3

Table 20.1.1 Continued on Next Page

Table 20.1.1 Continued


Item	Installation instructions	Text	Format	Clause reference
2.18	SUITABLE FOR MOUNTING WITHIN 1.2 m (4 ft) OF THE GROUND		S24-L2	13.4.8.8 13.4.8.10 13.4.8.12
2.19	MOUNT A MINIMUM OF 1.2 m (4 ft) ABOVE COOKING SURFACE		S24-L5	12.3.4.1
2.20	FOR USE IN CONCRETE ONLY		S24-L2	11.7.1.9 11.8.1.14
2.21	SUITABLE FOR USE IN POURED CONCRETE		S24-L2	11.4.6
2.22	SUITABLE FOR USE WITHIN COMMERCIAL COOKING HOOD		S24-L2	12.3.4.1
2.23	TYPE IC		S24-L3	11.5.1.1 11.8.1.11 11.8.1.13 11.8.4.1
2.24	INHERENTLY PROTECTED		S24-L3	11.5.1.1 11.8.1.13
2.25	OPEN CEILING MOUNT ONLY		S24-L1	11.7.1.12
2.26	CANOPY LUMINAIRE – NOT THERMALLY PROTECTED		S24-L2	11.5.1.1 11.7.1.11
2.27	SUITABLE FOR GROUND-MOUNTED RECESSED ONLY		S24-L2	11.5.1.1 11.7.1.10 11.8.1.14
2.28	Reserved			
2.29	Reserved			
2.30	Reserved			
2.31	PLACE LIGHT SOURCE NO CLOSER THAN ___ mm ( ___ in) TO ANY COMBUSTIBLE SURFACE		S24-L1	19.1.2
2.32	MAXIMUM AMBIENT OPERATING TEMPERATURE ___ °C	Verbatim	S24-L2	20.6.2 (MEX)
Item	User maintenance	Text	Format	Clause reference
3.1	MAX ___ WATTS TYPE ___ or MAX ___ W TYPE ___	Verbatim	S48-L1 for "MAX" and S24-L1 for remainder of marking text	7.1.2 7.2.5.2 7.2.6.1 7.3.1.2 11.8.2.1 11.8.2.5
3.2	MAX ___ WATTS TYPE ___ SHIELDED or MAX ___ W TYPE ___ SHIELDED	Verbatim	S48-L1 for "MAX" and S24-L1 for remainder of marking text	7.3.1.2
3.3	MAX ___ WATTS or MAX ___ W		S24-L1	6.5.1
3.4	MAX ___ AMPS or MAX ___ A		S24-L1	6.5.1
3.5	FUSE [identification] ___ AMPS		S24-L6	6.6.2
3.6	DISCONNECT POWER BEFORE SERVICING		S24-L1	6.4.1.4 7.3.2.3 9.5.3
3.7	AC ONLY		S24-L3	6.2.2
3.8	RELAMP WITH ___ WATTS TYPE ___ [lamp ANSI designation]		S24-L1	9.3.1 9.4.1.1 9.6.1
3.9	RELAMP WITH PAR LAMP ONLY		S24-L1	9.3.1
3.10	INSERT IN THIS LAMPHOLDER FIRST		S24-L1	7.3.2.1 9.5.1

Table 20.1.1 Continued

Item	Installation instructions	Text	Format	Clause reference
3.11	<b>BLINKING LIGHT OF THIS THERMALLY PROTECTED LUMINAIRE MAY INDICATE OVERHEATING</b>		S24-L1	11.8.1.10 11.8.1.11
3.12	<b>KEEP PROTECTIVE BARRIER IN PLACE or REPLACE REMOVABLE PARTS AFTER SERVICING</b>		S24-L1	7.3.1.4 7.3.1.4 (USA) 9.6.5
3.13	<b>UV LIGHT SOURCE – KEEP PROTECTIVE BARRIER IN PLACE</b>		S24-L1	9.6.6
3.14	<b>USE MAX ___ WATTS TYPE ___ ONLY</b>		S24-L1	9.6.2
3.15	<b>SEE OTHER (BACK) SIDE FOR RELAMPING INSTRUCTIONS</b>		S24-L1	11.8.2.4
3.16	<b>USE ___ VOLT LAMPS or USE ___ V LAMPS</b>		S24-L1	9.6.2
3.17	<b>CAUTION – RISK OF FIRE</b>	Verbatim	S24-L1	7.1.2 7.1.2 (CAN) 7.2.5.2 7.2.5.2 (CAN) 7.2.6.1 7.2.6.1 (CAN) 7.3.1.2 7.3.1.2 (CAN) 9.3.1 10.8.1 10.8.1 (CAN) 11.8.2.1 11.8.2.1 (CAN) 11.8.2.5 11.8.2.5 (CAN)
3.18	<b>CAUTION – RISK OF SHOCK</b>	Verbatim	S24-L1	6.4.1.4 6.4.1.4 (CAN) 7.3.2.1 7.3.2.1 (CAN) 7.3.2.3 7.3.2.3 (CAN) 9.5.1 9.5.1 (CAN) 9.5.3 9.5.3 (CAN)
3.19	<b>CAUTION – RISK OF PERSONAL INJURY</b>	Verbatim	S24-L1	8.6.5 9.6.6 9.6.6 (CAN)
3.20	<b>USE LAMP MARKED “SUITABLE FOR USE IN OPEN LUMINAIRES”</b>	Verbatim	S24-L1	7.3.1.2
3.21	<b>USE ONLY ___ TYPE ___ WATTS LAMPS</b>		S24-L1	8.6.4
3.22	<b>CAUTION – TO AVOID UV EXPOSURE RISK, USE ANSI TYPE ( ) LAMP ONLY. DO NOT INSTALL A LAMP THAT REQUIRES UV FILTERING.</b> (The blank space shall be filled with “E or O” or “O”.)	Verbatim	S24-L1	9.4.1.1
3.23	<b>CAUTION – UV EXPOSURE RISK. USE MFR. ( ) TYPE NO. ( ) LAMP OR ANSI TYPE “E” OR “O ONLY.”</b> (The blank spaces shall be filled with the lamp manufacturer’s name and lamp catalogue number).	Verbatim	S24-L1	9.4.2.1
3.24	<b>BALLAST DISCONNECT</b>	Verbatim	S24-L6	8.9.1 (CAN)

Table 20.1.1 Continued on Next Page

Table 20.1.1 Continued

Item	Installation instructions	Text	Format	Clause reference
3.25	<b>UNPLUG POWER SUPPLY CORD LOCATED AT</b> _____ <b>or</b> <b>UNPLUG CONNECTOR LOCATED AT</b> _____		S24-L6	8.9.1(CAN)
3.26	<b>DANGER – RISK OF SHOCK – DISCONNECT POWER BEFORE INSTALLATION</b>	Verbatim	S48-L5	8.10.2 (CAN)
3.27	<b>THIS LUMINAIRE IS PROVIDED WITH A FACTORY-INSTALLED EMERGENCY LIGHTING PACK AND MUST BE SERVICED BY A PERSON FAMILIAR WITH THE CONSTRUCTION AND OPERATION OF THE PRODUCT AND THE HAZARDS INVOLVED</b>		S24-L6	8.9.4 (CAN)
3.28	<b>DANGER – RISK OF SHOCK DISCONNECT ALL POWER AND DISABLE THE BATTERY PACK POWER BEFORE SERVICING BALLAST REPLACEMENT REQUIRES RECONNECTION OF WIRES THAT MAY BE ENERGIZED</b>		S48-L6 and S24-L6	8.9.4 (CAN)
ITEM	Miscellaneous markings	Text	Format	Clause reference
4.1	MANUFACTURER'S IDENTIFICATION		S16-L2	8.6.2 11.8.1.6 11.8.4.1 20.2.1 20.2.4
4.2	CATALOGUE NUMBER OR CAT. NO. OR SIMILAR PRODUCT IDENTIFICATION		S16-L2	8.6.2 11.8.1.6 11.8.4.1 20.2.2
4.3	DATE MARKING OR CODED FORM CONSISTING OF, AT LEAST, MONTH AND YEAR		S16-L2	20.2.1
4.4	<b>G or GR or GRD or GND or GRND or GROUND or</b> 		S24-L3	6.14.2.9 6.14.2.12
4.5	TO PREVENT ELECTRIC SHOCK, MATCH WIDE BLADE OF PLUG TO WIDE SLOT		S16-L5	6.10.4
4.6	FACTORY IDENTIFICATION		S16-L2	20.2.1
4.7	<b>THIS LUMINAIRE IS DESIGNED FOR USE WITH GERMICIDAL LAMPS AND MUST BE INSTALLED IN COMPLIANCE WITH COMPETENT TECHNICAL DIRECTIONS TO PREVENT THE USER'S EYE AND BARE SKIN FROM EXPOSURE TO HARMFUL UV RADIATION.</b>	Verbatim	S24-L1	8.6.5
NOTE: The text shown in the table represents the actual minimum size and typestyle required.				

**Table 20.1.2**  
**Format minimum size designation for marking height and typeface**

(See Clause 20.1.3.)

Size designation	Letter height		Font size (points)	Font typeface, upper case
	mm	(in)		
S16	1.6	(0.062)	6	Not specified
S24	2.4	(0.094)	10	Univers bold Arial bold Helvetica bold Zurich BT Bold
S32	3.2	(0.125)	12	Not specified
S48	4.8	(0.188)	19	Univers bold Arial bold Helvetica bold Zurich BT Bold

**Table 20.1.3**  
**Format location designation for marking**

(See Clauses 20.1.3 and 20.1.6.)

Location designation	Description	Label exposed to a dry/damp environment	Label exposed to a wet environment
L1	Visible during relamping, and after installation	Type P	Type P
L2	Visible during installation	Type N	Type P
L3	Visible during installation and inspection of wire connections, located near the supply connections	Type N	Type P
L4	On the smallest unit package or carton	Type T	Type T
L5	On an instruction sheet or tag	Type T	Type T
L6	Visible during component replacement	Type P	Type P

**Type P** designates a permanent label or nameplate that is intended to remain in the applied position for the lifetime of the luminaire under conditions of normal use. It provides information required for user maintenance over the expected life of the product. It is made of metal, plastic, or other material that complies with Clause 20.1.7.

**Type N** designates a non-permanent label or nameplate that is intended to remain in place only for the purpose of installation. It shows the certification mark, manufacturer's identification, and product identification. It is made of paper with an adhesive backing.

**Type T** designates a temporary label, instruction sheet, or tag that is not required after installation. It provides installation instructions, and information not required after installation. It is made of printed matter with or without adhesive and/or attachment, and is intended to be included with, or attached to, the product.

**Table 20.1.4**  
**Incandescent rough-in or housing section lamp replacement marking example**

(See Clause 11.8.2.5.)

CAUTION RISK OF FIRE	
FOR USE WITH [MFG NAME] TRIMS ONLY – SEE TRIM FOR NO.	
TRIM NO.	MAX LAMP WATTAGE AND TYPE
A100	100W A19
A210	100W A21
A300	150W R40

**Table 20.1.5**  
**HID rough-in or housing section lamp replacement marking example**

(See Clause 11.8.2.5.)

CAUTION RISK OF FIRE	
FOR USE WITH [MFG NAME] TRIMS ONLY – SEE TRIM FOR NO.	
TRIM NO.	MAX LAMP WATTAGE AND TYPE
B100	100W S54
B201	70W S62
B300	250W S50

**Table 20.1.6**  
**Trim or finishing section lamp replacement marking example**

(See Clause 11.8.2.5.)

CAUTION RISK OF FIRE	
FOR USE WITH [MFG NAME] TRIMS ONLY – SEE ROUGH-IN OR HOUSING FOR NO.	
HOUSING NO.	MAX LAMP WATTAGE AND TYPE
C100	100W S54
C201	70W S62
C300	2502 S50
C400	100W A19
	120W BR40
C500	150W PAR38
C600	150W A21

**ANNEX A (normative)**  
Standards for Components

**A.1 Component standards**

The ANCE, CSA, and UL standards listed below are to be used for the evaluation of components and features of products covered by this Standard. Components need only comply with the applicable component standard acceptable in the country where the product is to be used. The standards shall be considered to refer to the latest edition and all revisions published to that edition.

**Table A.1**  
**UL, CSA, IEC, NMX, and NOM Standards for components**

Component type	UL Standard	CSA Standard	IEC Publication (shall be replaced by UL and/or CSA Standard)	NMX or NOM Standard	Clause reference
Attachment plugs, receptacles, and connectors	<i>Standard for Attachment Plugs and Receptacles</i> UL 498	C22.2 No. 42 <i>General Use Receptacles, Attachment Plugs and Similar Wiring Devices</i> C22.2 No. 182.1 <i>Plugs, Receptacles, and Cable Connectors of the Pin and Sleeve Type</i> C22.2 No. 182.2 <i>Industrial Locking Type, Special Use Attachment Plugs, Receptacles and Connectors</i>	IEC 60084 <i>Plugs and socket-outlets for household and similar purposes</i> IEC 60309 <i>Plugs, socket-outlets and couplers for industrial purposes</i> IEC 60320 <i>Appliance couplers for household and similar general purposes</i>		6.2 6.5
Ballast, fluorescent type	<i>Standard for Fluorescent-Lamp Ballasts</i> UL 935	CAN/CSA-C22.2 No. 74 <i>Equipment for Use With Electric Discharge Lamps</i>	IEC 61347-2-3 <i>Lamp controlgear – Part 2-3: Particular requirements for a.c. supplied electronic ballasts for fluorescent lamps</i> IEC 61347-2-4 <i>Lamp controlgear – Part 2-4: Particular requirements for d.c. electronic ballasts for general lighting</i> IEC 61347-2-8 <i>Lamp controlgear – Part 2-8: Particular requirements for ballasts for fluorescent lamps</i>	NMX-J-198 <i>Ballasts for Fluorescent Lamps</i>	6.7 8.2

Table A.1 Continued on Next Page

Table A.1 Continued

Component type	UL Standard	CSA Standard	IEC Publication (shall be replaced by UL and/or CSA Standard)	NMX or NOM Standard	Clause reference
Ballast, HID type	<i>Standard for High-Intensity-Discharge Lamp Ballasts</i> UL 1029	CAN/CSA-C22.2 No. 74 <i>Equipment for Use With Electric Discharge Lamps</i>	IEC 61347-2-9 <i>Lamp controlgear – Part 2-9: Particular requirements for ballasts for discharge lamps (excluding fluorescent lamps)</i>	NOM-058-SCFL <i>Safety Requirements for Electrical Discharge Lamps</i> NMX-J-230 <i>Electrical Products Mercury Lamp Ballasts Methods of Testing</i>	6.7
Bonding and grounding of electrical equipment	<i>Standard for Grounding and Bonding Equipment</i> UL 467	CAN/CSA-C22.2 No. 0.4 <i>Bonding of Electrical Equipment</i>	IEC 60364-5-54 <i>Electrical installations of buildings – Part 5-54: Selection and erection of electrical equipment – Earthing arrangements, protective conductors and protective bonding conductors</i>		6.14
Cables, nonmetallic	<i>Standard for Nonmetallic-Sheathed Cables</i> UL 719	CAN/CSA-C22.2 No. 48 <i>Nonmetallic Sheathed Cable</i>	IEC 60227 <i>Polyvinyl chloride insulated cables of rated voltages up to and including 450/750 V</i>		
Capacitors	<i>Standard for Capacitors</i> UL 810	CAN/CSA-C22.2 No. 74 <i>Equipment for Use with Electric Discharge Lamps</i>	IEC 61048 <i>Auxiliaries for lamps – Capacitors for use in tubular fluorescent and other discharge lamp circuits</i>		6.8
Cord sets and power supply cords	<i>Standard for Cord Sets and Power-Supply Cords</i> UL 817	CAN/CSA-C22.2 No. 21 <i>Cord Sets and Power Supply Cords</i>	IEC 60320 <i>Appliance couplers for household and similar general purposes</i> IEC 60799 <i>Electrical accessories – Cord sets and interconnection cord sets</i>	NMX-J-195 <i>Cord Sets and Power Supply Cords</i>	6.9

Table A.1 Continued on Next Page

Table A.1 Continued

Component type	UL Standard	CSA Standard	IEC Publication (shall be replaced by UL and/or CSA Standard)	NMX or NOM Standard	Clause reference
Enclosures for electrical equipment	<i>Standard for Enclosures for Electrical Equipment</i> UL 50	CAN/CSA-C22.2 No. 94 <i>Special Purpose Enclosures</i>	IEC 60670 <i>Boxes and enclosures for electrical accessories for household and similar fixed electrical installations</i> IEC 60529 <i>Degrees of protection provided by enclosures (IP code)</i>		5.3 10.1

Table A.1 Continued

Component type	UL Standard	CSA Standard	IEC Publication (shall be replaced by UL and/or CSA Standard)	NMX or NOM Standard	Clause reference
Fuses	<p><i>Standard for Low-Voltage Fuses – Part 1: General Requirements</i> UL 248-1</p> <p><i>Standard for Low-Voltage Fuses – Part 2: Class C Fuses</i> UL 248-2</p> <p><i>Standard for Low-Voltage Fuses – Part 3: Class CA &amp; CB Fuses</i> UL 248-3</p> <p><i>Standard for Low-Voltage Fuses – Part 4: Class CC Fuses</i> UL 248-4</p> <p><i>Standard for Low-Voltage Fuses – Part 5: Class G Fuses</i> UL 248-5</p> <p><i>Standard for Low-Voltage Fuses – Part 6: Class H Non-Renewable Fuses</i> UL 248-6</p> <p><i>Standard for Low-Voltage Fuses – Part 13: Semiconductor Fuses</i> UL 248-13</p> <p><i>Standard for Low-Voltage Fuses – Part 14: Supplemental Fuses</i> UL 248-14</p> <p><i>Standard for Low-Voltage Fuses – Part 15: Class T Fuses</i> UL 248-15</p> <p><i>Standard for Low-Voltage Fuses – Part 16: Test Limiters</i> UL 248-16</p>	<p>C22.2 No. 248.1 <i>Low-Voltage Fuses – Part 1: General Requirements</i></p> <p>C22.2 No. 248.2 <i>Low-Voltage Fuses – Part 2: Class C Fuses</i></p> <p>C22.2 No. 248.3 <i>Low-Voltage Fuses – Part 3: Class CA &amp; CB Fuses</i></p> <p>C22.2 No. 248.4 <i>Low-Voltage Fuses – Part 4: Class CC Fuses</i></p> <p>C22.2 No. 248.5 <i>Low-Voltage Fuses – Part 5: Class G Fuses</i></p> <p>C22.2 No. 248.6 <i>Low-Voltage Fuses – Part 6: Class H Non-Renewable Fuses</i></p> <p>C22.2 No. 248.13 <i>Low-Voltage Fuses – Part 13: Semiconductor Fuses</i></p> <p>C22.2 No. 248.14 <i>Low-Voltage Fuses – Part 14: Supplemental Fuses</i></p> <p>C22.2 No. 248.15 <i>Low-Voltage Fuses – Part 15: Class T Fuses</i></p> <p>C22.2 No. 248.16 <i>Low-Voltage Fuses – Part 16: Test Limiters</i></p>	<p>IEC 60127-1 <i>Miniature Fuses – Part 1 Definitions for miniature fuses and general requirements for miniature fuse-links</i></p>	<p>NMX-J009/248/1-2000-ANCE <i>Low-Voltage Fuses</i></p> <p>NMX-J009/248/2-2000-ANCE <i>Low-Voltage Fuses – Class C Fuses</i></p> <p>NMX-J009/248/3-2000-ANCE <i>Low-Voltage Fuses – Class CA &amp; CB Fuses</i></p> <p>NMX-J009/248/4-2000-ANCE <i>Low-Voltage Fuses – Class CC Fuses</i></p> <p>NMX-J009/248/5-2000-ANCE <i>Low-Voltage Fuses – Class G Fuses</i></p> <p>NMX-J009/248/6-2000-ANCE <i>Low-Voltage Fuses – Class H Non-Renewable Fuses</i></p> <p>NMX-J009/248/13-2000-ANCE <i>Low-Voltage Fuses – Semiconductor Fuses</i></p> <p>NMX-J009/248/14-2000-ANCE <i>Low-Voltage Fuses – Supplemental Fuses</i></p> <p>NMX-J009/248/15-2000-ANCE <i>Low-Voltage Fuses – Class T Fuses</i></p> <p>NMX-J009/248/16-2000-ANCE <i>Low-Voltage Fuses – Test Limiters</i></p>	9.6e
Fuseholders	<p><i>Standard for Fuseholders</i> UL 512</p>	<p>C22.2 No. 39 <i>Fuseholder Assemblies</i></p>	<p>IEC 60127-6 <i>Miniature fuses – Part 6: Fuseholders for miniature cartridge fuse-links</i></p>		9.6
General requirements		<p>CAN/CSA-C22.2 No. 0 <i>General Requirements – Canadian Electrical Code</i></p>			

Table A.1 Continued

Component type	UL Standard	CSA Standard	IEC Publication (shall be replaced by UL and/or CSA Standard)	NMX or NOM Standard	Clause reference
Ground-fault circuit interrupters	<i>Standard for Ground-Fault Circuit-Interrupters</i> UL 943	CAN/CSA-C22.2 No. 144 <i>Ground Fault Circuit Interrupters</i>			
Industrial control equipment	<i>Standard for Industrial Control Equipment</i> UL 508	C22.2 No. 14 <i>Industrial Control Equipment</i>	IEC 60204 <i>Safety of machinery – Electrical equipment of machines</i>		
Insulating bushings	<i>Standard for Insulating Bushings</i> UL 635	CAN/CSA-C22.2 No. 18.2 <i>Outlet Boxes, Conduit Boxes, Fittings, and Associated Hardware</i>	IEC 60204 <i>Safety of machinery – Electrical equipment of machines</i>		5.15
Insulating material	<i>Standard for Systems of Insulating Materials – General</i> UL 1446	C22.2 No. 0 <i>General Requirements – Canadian Electrical Code</i>	IEC 60085 <i>Electrical insulation – Thermal classification</i> IEC 62114 <i>Electrical insulation systems – Thermal classification</i>		5.4 5.7
Insulating tape	<i>Standard for Polyvinyl Chloride, Polyethylene and Rubber Insulating Tape</i> UL 510	C22.2 No. 197 <i>PVC Insulating Tape</i>			6.12
Lamps, incandescent	Nil	C22.2 No. 84 <i>Incandescent Lamps</i>	IEC 60357 <i>Tungsten halogen lamps (non-vehicle) – Performance specification</i> IEC 60432-1 <i>Incandescent lamps – Safety specifications – Part 1: Tungsten filament lamps for domestic and similar general lighting purposes</i> IEC 60432-2 <i>Incandescent lamps – Part 2: Tungsten halogen lamps for domestic and similar general lighting purposes</i>		19.8 Table 19.3.3.1
Lamps, miniature			IEC 60983 <i>Miniature lamps</i>		

Table A.1 Continued on Next Page

Table A.1 Continued

Component type	UL Standard	CSA Standard	IEC Publication (shall be replaced by UL and/or CSA Standard)	NMX or NOM Standard	Clause reference
Lampholders	<i>Standard for Edison-base Lampholders</i> UL 596	C22.2 No. 43 <i>Lampholders</i>	IEC 60238 <i>Edison screw lampholders</i> IEC 60400 <i>Lampholders for tubular fluorescent lamps and starterholders</i>	NMX-J-024-ANCE <i>Edison-Base Lampholders</i>	6.3 7.3.3 8.4
Lamp starters and starter holders for fluorescent lamps	<i>Standard for Lampholder Starters and Starter holders For Fluorescent Lamps</i> UL 542	C22.2 No. 43 <i>Lampholders</i>	IEC 60155 <i>Glow-starters for fluorescent lamps</i> IEC 60400 <i>Lampholders for tubular fluorescent lamps and starter holders</i> IEC 60838 <i>Miscellaneous lampholders</i>		8.4
Lampholders, bayonet Base	Nil	C22.2 No. 43 <i>Lampholders</i>	IEC 61184 <i>Bayonet lampholders</i>		Table 7.3.3.1
Lamp starting devices	<i>Standard for High-Intensity-Discharge Lamp Ballasts</i> UL 1029	CAN/CSA-C22.2 No. 74 <i>Equipment for Use with Electrical Discharge Lamps</i>	IEC 61347-2-1 <i>Lamp controlgear – Part 2-1: Particular requirements for starting devices (other than glow starters)</i>		
Marking systems	<i>Standard for Marking and Labeling Systems</i> UL 969	C22.2 No. 0.15 <i>Adhesive Labels</i>	Nil	Nil	20.1
Outlet boxes and fittings	<i>Standard for Metallic Outlet Boxes</i> UL 514A <i>Standard for Conduit, Tubing and Cable Fittings</i> UL 514B <i>Standard for Nonmetallic Outlet Boxes, Flush-Device Boxes, and Covers</i> UL 514C	CAN/CSA-C22.2 No. 18 <i>Outlet Boxes, Conduit Boxes, Fittings, and Associated Hardware</i> CAN/CSA-C22.2 No. 85 <i>Rigid PVC Boxes and Fittings</i>	Nil		
Photocontrols	<i>Standard for Plug-in, Locking Type Photocontrols for Use With Area Lighting</i> UL 773	Nil	Nil		6.4.1.4
Poles		C22.2 No. 206 <i>Lighting Poles</i>			10.3.13 (CAN)

Table A.1 Continued on Next Page

Table A.1 Continued

Component type	UL Standard	CSA Standard	IEC Publication (shall be replaced by UL and/or CSA Standard)	NMX or NOM Standard	Clause reference
Polymeric materials	<p><i>Standard for Polymeric Materials – Short Term Property Evaluations</i> UL 746A</p> <p><i>Standard for Polymeric Materials – Long Term Property Evaluations</i> UL 746B</p> <p><i>Standard for Polymeric Materials – Use in Electrical Equipment Evaluations</i> UL 746C</p> <p><i>Standard for Polymeric Materials – Fabricated Parts</i> UL 746D</p> <p><i>Standard for Polymeric Materials – Industrial Laminates, Filament Wound Tubing, Vulcanized Fibre, and Materials Used in Printed Wiring</i> UL 746E</p> <p><i>Standard for Tests for Flammability of Plastic Materials for Parts in Devices and Appliances</i> UL 94</p>	CAN/CSA-C22.2 No. 0.17 <i>Evaluation of Properties of Polymeric Materials</i>	Nil	Nil	5.7  16.6.1  16.8.1
Power supplies	<p><i>Standard for Power Units Other Than Class 2</i> UL 1012</p> <p><i>Standard for Class 2 Power Units</i> UL 1310</p>	<p>C22.2 No. 107.1 <i>General Use Power Supplies</i></p> <p>CAN/CSA-C22.2 No. 60950-1-1 <i>Information Technology Equipment – Safety – Part 1: General Requirements</i></p>	IEC 61347-2-2 <i>Lamp controlgear – Part 2-2: Particular requirements for d.c or a.c supplied electronic step-down convertors for filament lamps</i>		
Printed-wiring boards	<i>Standard for Printed-Wiring Boards</i> UL 796	See Annex F of this Standard	IEC 61191 <i>Printed board assemblies</i>		

Table A.1 Continued on Next Page

**Table A.1 Continued**

Component type	UL Standard	CSA Standard	IEC Publication (shall be replaced by UL and/or CSA Standard)	NMX or NOM Standard	Clause reference
Raceways and fittings	<i>Standard for Surface Metal Raceways and Fittings</i> UL 5	C22.2 No. 62 <i>Surface Raceway Systems</i>	IEC 61084 <i>Cable trunking and ducting systems for electrical installations</i>		
Supplementary protectors	<i>Standard for Supplementary Protectors for Use in Electrical Equipment</i> UL 1077	CAN/CSA-C22.2 No. 235 <i>Supplementary Protectors</i>			
Starters, fluorescent	<i>Standard for Lampholders, Starters, and Starter Holders for Fluorescent Lamps</i> UL 542	CAN/CSA-C22.2 No. 74 <i>Equipment for Use with Electrical Discharge Lamps</i>	IEC 60155 <i>Glow-starters for fluorescent lamps</i>		
Switches	<i>Standard for General-Use Snap Switches</i> UL 20 <i>Standard for Clock-Operated Switches</i> UL 917 <i>Standard for Special-Use Switches</i> UL 1054	C22.2 No. 55 <i>Special Use Switches</i> C22.2 No. 111 <i>General-Use Snap Switches</i> CAN/CSA-C22.2 No. 177 <i>Clock-Operated Switches</i>	IEC 60730-2 Series <i>Automatic electrical Controls for household and similar use</i>	J-NMX-005General Switches for Fixed Electrical Installations – General Requirements and Test Methods J-NMX-508Wiring Devices – Safety Requirements – Specifications and Test Methods J-NMX-515Distribution and Control Equipment – Safety General Requirements – Specifications and Test Methods	6.4
Terminal blocks	<i>Standard for Terminal Blocks</i> UL 1059	C22.2 No. 158 <i>Terminal Blocks</i>			6.14.2.12 6.15

Table A.1 Continued

Component type	UL Standard	CSA Standard	IEC Publication (shall be replaced by UL and/or CSA Standard)	NMX or NOM Standard	Clause reference
Thermal protectors	<i>Standard for Temperature-Indicating and -Regulating Equipment</i> UL 873	C22.2 No. 209 <i>Thermal Cut-offs</i>	IEC 60730-1 <i>Automatic electrical controls for household and similar use: Part 1 General requirements</i> IEC 60730-2-3 <i>Automatic electrical controls for household and similar use: Part 2 Particular requirements for thermal protectors for ballasts for tubular fluorescent lamps</i>		11.5
Transformers	<i>Standard for Low-voltage Transformers – Part 1: General Requirements</i> UL 5085-1 <i>Standard for Low-voltage Transformers – Part 2: General Purpose Transmformers</i> UL 5085-2 <i>Standard for Low-voltage Transformers – Part 3: Class 2 and Class 3 Transformers</i> UL 5085-3	C22.2 No. 66 <i>Specialty Transformers</i> CAN/CSA-C22.2 No. 223 <i>Power Supplies with Extra-Low Voltage Class 2 Outputs</i>	IEC 61558-1 <i>Safety of power transformers, power supply units and similar Part 1 General requirements and tests</i> IEC 61558-2-4 <i>Part 2: Particular requirements for isolating transformers for general use</i> IEC 61558-2-6 <i>Part 2: Particular requirements for safety isolating transformers for general use</i>		
Tubing, EMT conduit	<i>Standard for Electrical Metallic Tubing – Steel</i> UL 797	C22.2 No. 83 <i>Electrical Metallic Tubing</i>	Nil		
Tubing, flexible metallic conduit, liquid-tight	<i>Standard for Liquid-Tight Flexible Steel Conduit</i> UL 360	C22.2 No. 56 <i>Flexible Metal Conduit and Liquid-Tight Flexible Metal Conduit</i>	Nil		
Tubing, extruded insulated	<i>Standard for Extruded Insulating Tubing</i> UL 224	C22.2 No. 198.1 <i>Extruded Insulating Tubing</i>	Nil		5.4
Tubing, flexible nonmetallic	<i>Standard for Tests for Surface Burning Characteristics of Building Materials</i> UL 723	C22.2 No. 56 <i>Flexible Nonmetallic Tubing</i>	Nil		12.2.2.3

Table A.1 Continued on Next Page

Table A.1 Continued

Component type	UL Standard	CSA Standard	IEC Publication (shall be replaced by UL and/or CSA Standard)	NMX or NOM Standard	Clause reference
Wire connector terminals	<i>Standard for Electrical Quick-Connect Terminals</i> UL 310 <i>Standard for Wire Connectors</i> UL 486A-486B <i>Standard for Equipment Wiring Terminals for Use with Aluminum and/or Copper Conductors</i> UL 486E <i>Standard for Component Connectors for Use in Data, Signal, Control and Power Applications</i> UL 1977	C22.2 No. 65 <i>Wire Connectors</i> C22.2 No. 153 <i>Quick Connect Terminals</i>	IEC 60998 <i>Connecting devices for low-voltage circuits for household and similar purposes</i>		6.13.4.1
Wiring space and wire bending space in enclosures	Nil	C22.2 No. 0.12 <i>Wire Space and Wire Bending Space in Enclosures for Equipment Rated 750 V or Less</i>			
Wires and cables	<i>Standard for Thermoset-Insulated Wires and Cables</i> UL 44 <i>Standard for Flexible Cord and Fixture Wire</i> UL 62 <i>Standard for Thermoplastic-Insulated Wires and Cables</i> UL 83 <i>Standard for Appliance Wiring Material</i> UL 758 <i>Reference Standard for Electrical Wires, Cables, and Flexible Cords</i> UL 1581	C22.2 No. 35 <i>Extra-Low-Voltage Control Circuit Cable, Low-Energy Control Cables and Extra-Low Voltage Control Cable</i> C22.2 No. 49 <i>Flexible Cords and Cables</i> C22.2 No. 127 <i>Equipment and Lead Wires</i> CAN/CSA-C22.2 No. 210.2 <i>Appliance Wiring Material Products</i>		NMX-J-436 <i>Conductors – Flexible cords for robust use and extra robust use up to 600 V – Specifications</i>	6.9

**Annex B (CAN) (normative)**  
**Markings – French Translations**

**Table B.1 (CAN)**  
**Markings – French translations**

Item	Installation instructions	Text	Format	Clause reference
1.1	MIN ___ °C SUPPLY CONDUCTORS	Verbatim	S24-L3 and S32-L4	6.7.2.4 6.15.1.5 6.15.1.5 (CAN) 7.2.3.2 7.2.3.3 7.2.3.4 7.2.3.5 8.5.2 10.6.9 (USA) 10.6.9 (CAN) 10.6.10 (CAN) 11.8.1.2 12.3.4.1
	LES FILS D'ALIMENTATION ___ °C MIN			
1.2	CONNECT TO BRANCH CIRCUIT RATED ___ AMPS MAX		S24-L3	11.8.1.8 11.8.1.9
	POUR CONNEXION À UNE DÉRIVATION DE ___ AMPÈRES MAX			
1.3	___ VOLTS ___ AMPS ___ WATTS ___ HERTZ or ___ V ___ A ___ W ___ HZ		S24-L3	20.2.3
	___ VOLTS ___ AMPÈRES ___ WATTS ___ HERTZ ou ___ V ___ A ___ W ___ HZ			
1.4	___ VOLTS ___ HERTZ or ___ V ___ HZ		S24-L3	6.2.2 7.1.4
	___ VOLTS ___ HERTZ ou ___ V ___ HZ			
1.5	N or NEUTRAL or W or WHITE		S24-L3	6.10.1
	[Aucune traduction ne s'applique]			
1.6	SUITABLE FOR OPERATION IN AMBIENT NOT EXCEEDING ___ °C		S24-L2	12.4.3.1
	PEUT ÊTRE UTILISÉ À UNE TEMPÉRATURE AMBIANTE N'EXCÉDANT PAS ___ °C			
1.7	SUITABLE FOR USE AS A RACEWAY		S24-L3	5.20.3
	PEUT ÊTRE UTILISÉ COMME CANALISATION			
1.8	ASSEMBLE PART [Catalogue Number] ONLY WITH PART [Catalogue Number]		S24-L4	5.2.3 20.2.4
	ASSEMBLER LA PIÈCE [référence au catalogue] SEULEMENT AVEC LA PIÈCE [référence au catalogue]			
1.9	USE ONLY WITH [Manufacturer] [Catalogue Number] TRIMS		S24-L2	11.8.1.7
	UTILISER SEULEMENT AVEC DES GARNITURES [fabricant] [référence au catalogue]			
1.10	USE ONLY WITH [Manufacturer] [Catalogue Number] LUMINAIRE		S24-L2	11.7.1.8 (USA) 12.2.4.4 (USA)
	UTILISER SEULEMENT AVEC UN LUMINAIRE [fabricant] [référence au catalogue]			
1.11	USE WITH LISTED LIGHT DIFFUSER		S24-L2	12.2.4.3 (USA)
	UTILISER AVEC UN DIFFUSEUR DE LUMIÈRE RÉPERTORIÉ			

Table B.1 (CAN) Continued on Next Page

Table B.1 (CAN) Continued

Item	Installation instructions	Text	Format	Clause reference
1.12	PROPRIETARY WIRING SYSTEM [Name, Part Number, Cautionary Marking]		S24-L2	6.15.1.1
	RÉSEAU DE CÂBLAGE BREVETÉ [nom, numéro de la pièce, mise en garde]			
1.13	DO NOT INSTALL INSULATION WITHIN 76 mm (3 in) OF ANY PART OF THE LUMINAIRE		S24-L2	11.8.1.10 11.8.4.1
	NE PAS METTRE L'ISOLANT À MOINS DE 76 mm (3 po) DE TOUTE PARTIE DU LUMINAIRE			
1.14	VAPOR BARRIER MUST BE SUITABLE FOR 90 °C		S24-L2	11.8.1.12 11.8.1.12 (USA)
	LE PARE-VAPEUR DOIT CONVENIR POUR 90 °C			
1.15	SUITABLE FOR AIR-HANDLING USE		S24-L2	12.2.4.1
	CONVIENT AU TRAITEMENT DE L'AIR			
1.16	VENTILATING OR COOLED AIR ONLY		S24-L2	12.2.4.2
	AIR DE VENTILATION OU AIR REFROIDI SEULEMENT			
1.17	INSTALL ONLY IN ENVIRONMENTAL AIR-HANDLING SPACES WHERE A COMPLETE METAL-ENCLOSED WIRING SYSTEM IS PROVIDED		S24-L3	12.2.4.7
	INSTALLER SEULEMENT DANS DES ESPACES SERVANT AU TRAITEMENT DE L'AIR OÙ LES RÉSEAUX DE CÂBLAGE AU COMPLET SONT SOUS ENVELOPPE MÉTALLIQUE			
1.18	ONLY FOR USE IN ENVIRONMENTAL AIR-HANDLING SPACES OTHER THAN DUCTS OR PLENUMS WHEN ATTACHED TO PARTS THAT COVER VENT OPENINGS IN ACCORDANCE WITH THE CEILING FIRE-RATING SPECIFICATION	Verbatim	S24-L2	12.2.4.6
	UTILISER UNIQUEMENT DANS DES ESPACES SERVANT AU TRAITEMENT DE L'AIR AUTRES QUE DES CONDUITS OU DES PLÉNOMS S'ILS SONT FIXÉS À DES PIÈCES COUVRANT LES OUVERTURES DE VENTILATION, CONFORMÉMENT AUX EXIGENCES VISANT LA RÉSISTANCE AU FEU DU PLAFOND			
1.19	INSTALL WITH MINIMUM SPACINGS BETWEEN (a) CENTER-TO-CENTER OF ADJACENT LUMINAIRES: ___ mm (___ in); (b) TOP OF LUMINAIRE TO OVERHEAD BUILDING MEMBER: ___ mm (___ in); (c) LUMINAIRE CENTER TO SIDE BUILDING MEMBER: ___ mm (___ in).		S24-L2	11.7.1.11 11.8.3.1 12.3.4.2
	ASSURER LES DÉGAGEMENTS MINIMAUX SUIVANTS: (a) ENTRE L'ENTRAXE DES LUMINAIRES ADJACENTS ___ mm (___ po) (b) ENTRE LE DESSUS DU LUMINAIRE ET L'ÉLÉMENT DE CHARPENTE SE TROUVANT AU-DESSUS ___ mm (___ po) (c) ENTRE LE CENTRE DU LUMINAIRE ET UN ÉLÉMENT DE CHARPENTE LATÉRAL ___ mm (___ po)			
1.20	INSTALL PHOTOCONTROL OR SHORTING PLUG		S24-L2	6.4.1.5
	INSTALLER UNE CELLULE PHOTOÉLECTRIQUE OU UNE PRISE COURT-CIRCUITANTE			

Table B.1 (CAN) Continued

Item	Installation instructions	Text	Format	Clause reference
1.21	THIS LUMINAIRE MUST BE MOUNTED OR SUPPORTED INDEPENDENTLY OF AN OUTLET BOX		S24-L2	10.2.5 10.2.5 (USA)
	CE LUMINAIRE NE DOIT PAS ÊTRE MONTÉ SUR UNE BOÎTE DE SORTIE NI SUPPORTÉ PAR UNE TELLE BOÎTE			
1.22	FOR CHAIN OR HOOK SUSPENSION ONLY		S24-L2	10.8.4
	SUSPENDRE SEULEMENT À L'AIDE DE CHAÎNES OU DE CROCHETS			
1.23	LIMIT RANGE OF ADJUSTMENT TO [instruction]		S24-L1	13.4.9.2
	LIMITER L'AJUSTEMENT À ___ [instructions]			
1.24	FOR USE ONLY WITH A LUMINAIRE WITH INTEGRAL SUPPLY CONDUCTOR SUPPORT		S24-L2	10.3.9
	UTILISER UNIQUEMENT AVEC UN LUMINAIRE ÉQUIPÉ D'UN SUPPORT INTÉGRÉ POUR CONDUCTEURS D'ALIMENTATION			
1.25	PUSH CONDUCTORS INTO JUNCTION BOX		S24-L2	7.2.7.2
	ENFONCER LES FILS DANS LA BOÎTE DE JONCTION			
1.26	FOR USE IN NON-FIRE-RATED INSTALLATIONS ONLY		S24-L2	11.4.7 11.8.5.2
	UTILISER SEULEMENT DANS DES INSTALLATIONS OÙ LE DEGRÉ DE RÉSISTANCE AU FEU N'EST PAS ÉTABLI			
1.27	FOR LINE VOLTS-AMPERES MULTIPLY TOTAL LAMP WATTAGE BY 1.5		S24-L3	8.6.1
	POUR LA TENSION VECTORIELLE (VA) DU SECTEUR, MULTIPLIER LA PUISSANCE TOTALE EN WATTS DES AMPOULES PAR 1,5			
1.28	FOR LINE VOLTS-AMPERES MULTIPLY TOTAL LAMP WATTAGE BY 2.5		S24-L3	8.6.1
	POUR LA TENSION VECTORIELLE (VA) DU SECTEUR, MULTIPLIER LA PUISSANCE TOTALE EN WATTS DES AMPOULES PAR 2,5			
1.29	FOR LINE VOLTS-AMPERES MULTIPLY TOTAL LENGTH OF ALL LAMPS IN INCHES BY ___		S24-L3	8.6.1
	POUR LA TENSION VECTORIELLE (VA) DU SECTEUR, MULTIPLIER LA LONGUEUR TOTALE DES AMPOULES EN po PAR ___			
1.30	USE THERMALLY PROTECTED BALLAST FOR TYPE ___ LAMPS		S24-L2	8.6.3
	UTILISER UN BALLAST PROTÉGÉ THERMIQUEMENT POUR LES LAMPES DE TYPE ___			

Table B.1 (CAN) Continued

Item	Installation instructions	Text	Format	Clause reference
1.31	THIS PRODUCT MUST BE INSTALLED IN ACCORDANCE WITH THE APPLICABLE INSTALLATION CODE BY A PERSON FAMILIAR WITH THE CONSTRUCTION AND OPERATION OF THE PRODUCT AND THE HAZARDS INVOLVED		S24-L4	10.8.1 20.5.1
	CE PRODUIT DOIT ÊTRE INSTALLÉ SELON LE CODE D'INSTALLATION PERTINENT, PAR UNE PERSONNE QUI CONNAÎT BIEN LE PRODUIT ET SON FONCTIONNEMENT AINSI QUE LES RISQUES INHÉRENTS			
1.32	CONSULT A QUALIFIED ELECTRICIAN TO ENSURE CORRECT BRANCH CIRCUIT CONDUCTOR		S24-L4	10.8.1 10.8.1 (CAN)
	CONSULTER UN ÉLECTRICIEN QUALIFIÉ POUR VOUS ASSURER QUE LES CONDUCTEURS DE LA DÉRIVATION SONT ADÉQUATS			
1.33	INSTALLATION OR ASSEMBLY INSTRUCTIONS		S16-L5	5.1.2 5.2.2 5.15.2.4 5.15.2.5 6.14.1.3 6.14.2.13 6.15.1.1 6.15.1.3 7.3.1.2 10.2.5 10.2.5 (USA) 10.2.6 10.6.7 (USA) 11.1.4 11.8.4.1 11.8.5.1 13.4.9.3
	[Aucune traduction ne s'applique]			
1.34	ROUGH-IN SECTION FOR USE WITH FINISHING SECTION ____		S16-L2	11.8.1.5
	SECTION NON FINIE À UTILISER AVEC SECTION DE FINITION ____			
1.35	FINISHING-SECTION FOR USE WITH ROUGH-IN SECTION ____		S16-L2	11.8.4.1
	SECTION DE FINITION À UTILISER AVEC SECTION NON FINIE ____			
1.36	ROUGH-IN SECTION ____ FOR CONVERTIBLE RECESSED LUMINAIRE		S16-L2	11.8.4.1
	SECTION NON FINIE _____ POUR LUMINAIRE ENCASTRÉ CONVERTIBLE			
1.37	FOR CABLE USE ONLY — NOT FOR PULLING WIRES		S24-L3	11.3.3
	UTILISER POUR LE CÂBLAGE SEULEMENT – NON POUR LE TIRAGE DE FILS			

Table B.1 (CAN) Continued

Item	Installation instructions	Text	Format	Clause reference
1.38	TYPE-IC TRIMS/FINISHING SECTIONS: AA BB CC [etc.] TYPE NON-IC TRIMS/FINISHING SECTIONS: AA BB CC [etc.]		S24-L3	11.8.4.1
	GARNITURES DE TYPE IC/SECTIONS DE FINITIONS : AA, BB, CC [ETC.] GARNITURES DE TYPE NON IC/SECTIONS DE FINITIONS : AA, BB, CC [ETC.]			
1.39	FOR USE IN ONE- AND TWO-FAMILY DWELLINGS ONLY or NOT FOR USE IN ENVIRONMENTAL AIR-HANDLING SPACES		S24-L3	11.8.5.2
	POUR UTILISATION UNIQUEMENT DANS DES UNIFAMILIALES OU DES DUPLEX ou NE PAS UTILISER DANS DES ESPACES SERVANT AU TRAITEMENT DE L'AIR			
1.40	MAXIMUM OF _____ AWG THROUGH BRANCH CIRCUIT CONDUCTOR SUITABLE FOR _____ °C PERMITTED IN BOX		S24-L3	11.3.3 14.10.3 14.11.2
	UN MAXIMUM DE _____ CONDUCTEURS DE DÉRIVATION _____ AWG CONVENANT POUR _____ °C SONT PERMIS DANS UNE BOÎTE			
1.41	USE BALLAST FOR _____ WATT _____ TYPE LAMP		S24-L2	6.7.2.3
	UTILISER UN BALLAST CONVENANT À DES AMPOULES DE _____ W DE TYPE _____			
1.42	THIS LUMINAIRE IS PROVIDED WITH A FACTORY-INSTALLED EMERGENCY LIGHTING BATTERY PACK		S24-L2	8.7
	CE LUMINAIRE EST ÉQUIPÉ EN USINE D'UNE BATTERIE DES LUMIÈRES D'URGENCE			
1.43	FOR INSTALLATION USE SUPPLY CONDUCTORS RATED _____ °C	Verbatim	S24-L3	20.6.2 (MEX)
	UTILISER DES CONDUCTEURS D'ALIMENTATION CONVENANT À _____ °C POUR L'INSTALLATION			
1.44	IMPORTANT SAFETY INSTRUCTIONS	Verbatim	S24-L5	8.10.2 (CAN)
	MESURES DE SÉCURITÉ À RESPECTER			
Item	Mounting locations	Text	Format	Clause reference
2.1	DRY LOCATIONS ONLY	Verbatim	S24-L2	13.1.2
	POUR EMPLACEMENTS SECS SEULEMENT			
2.2	SUITABLE FOR DAMP LOCATIONS	Verbatim	S24-L2	13.1.2 13.3.1.1
	CONVIENT AUX EMPLACEMENTS HUMIDES			
2.3	SUITABLE FOR WET LOCATIONS	Verbatim	S24-L2	13.1.2 13.4.9.1
	CONVIENT AUX EMPLACEMENTS MOUILLÉS			
2.4	OUTDOOR USE ONLY	Verbatim	S24-L2	8.2.1
	POUR INSTALLATION À L'EXTÉRIEUR SEULEMENT			

Table B.1 (CAN) Continued

Item	Installation instructions	Text	Format	Clause reference
2.5	NOT FOR USE IN DWELLINGS	Verbatim	S24-L3	6.7.1.1 6.15.1.4 7.2.3.2 10.6.9 (USA) 10.6.9 (CAN) 10.6.10 (CAN) 11.8.1.2
	NE PAS UTILISER DANS LES LOGEMENTS			
2.6	NONCOMBUSTIBLE SURFACE ONLY	Verbatim	S24-L3	10.4.9 10.8.3 11.7.1.10 20.4.2
	POUR SURFACES INCOMBUSTIBLES SEULEMENT			
2.7	ACCESS ABOVE CEILING REQUIRED	Verbatim	S24-L2	11.6.1.1 11.8.1.4
	ACCÈS REQUIS AU-DESSUS DU PLAFOND			
2.8	ACCESS BEHIND WALL REQUIRED	Verbatim	S24-L2	11.8.1.4
	ACCÈS REQUIS DERRIÈRE LE MUR			
2.9	FOR NONCOMBUSTIBLE CEILING PLENUM ONLY		S24-L2	12.2.4.5
	POUR INSTALLATION DANS UN PLÉNUM DE PLAFOND INCOMBUSTIBLE SEULEMENT			
2.10	WALL MOUNT ONLY	Verbatim	S24-L2	7.2.7.1 10.7.2 14.2.1
	INSTALLATION MURALE SEULEMENT			
2.11	COVERED CEILING MOUNT ONLY		S24-L2	13.4.8.3 13.4.8.6
	INSTALLATION SUR PLAFOND COUVERT SEULEMENT			
2.12	SUITABLE FOR UNDER-CABINET MOUNT	Verbatim	S24-L2	10.8.2 (USA)
	PEUT ÊTRE FIXÉ SOUS UNE ARMOIRE			
2.13	MOUNTING ORIENTATION – (Such as this end up)		S24-L2	20.4.1
	SENS DE MONTAGE [par exemple, cette extrémité vers le haut]			
2.14	SUITABLE FOR GROUND-MOUNTED RECESSED		S24-L2	13.4.8.13
	PEUT ÊTRE ENCASTRÉ DANS LE SOL			
2.15	Reserved			
	Réservé			
2.16	SUITABLE FOR CONTINUOUS ROW MOUNTING		S24-L2	5.19.1
	PEUT ÊTRE MONTÉ EN RANGÉE CONTINUE			
2.17	INSTALL IN BUILDINGS OF FIRE-RESISTIVE CONSTRUCTION – MOUNT ON NONCOMBUSTIBLE MATERIAL		S24-L2	11.8.1.3
	INSTALLER DANS DES BÂTIMENTS RÉSISTANTS AU FEU – MONTER SUR DES MATÉRIAUX INCOMBUSTIBLES			
2.18	SUITABLE FOR MOUNTING WITHIN 1.2 m (4 ft) OF THE GROUND		S24-L2	13.4.8.8 13.4.8.10 13.4.8.12
	PEUT ÊTRE INSTALLÉ À MOINS DE 1,2 m (4 pi) DU SOL			
2.19	MOUNT A MINIMUM OF 1.2 m (4 ft) ABOVE COOKING SURFACE		S24-L5	12.3.4.1
	INSTALLER À AU MOINS 1,2 m (4 pi) AU-DESSUS DE LA SURFACE DE CUISSON			
2.20	FOR USE IN CONCRETE ONLY		S24-L2	11.7.1.9 11.8.1.14
	POUR INSTALLATION DANS LE BÉTON SEULEMENT			

Table B.1 (CAN) Continued

Item	Installation instructions	Text	Format	Clause reference
2.21	SUITABLE FOR USE IN POURED CONCRETE		S24-L2	11.4.6
	PEUT ÊTRE UTILISÉ DANS LE BÉTON COULÉ			
2.22	SUITABLE FOR USE WITHIN COMMERCIAL COOKING HOOD		S24-L2	12.3.4.1
	PEUT ÊTRE UTILISÉ DANS UNE HOTTE DE CUISSON COMMERCIALE			
2.23	TYPE IC		S24-L3	11.5.1.1
	TYPE IC			11.8.1.11
2.24	INHERENTLY PROTECTED		S24-L3	11.8.1.13
	PROTECTION INHÉRENTE			11.8.4.1
2.25	OPEN CEILING MOUNT ONLY		S24-L1	11.5.1.1
	POUR MONTAGE DANS UN PLAFOND OUVERT SEULEMENT			11.7.1.12
2.26	CANOPY LUMINAIRE – NOT THERMALLY PROTECTED		S24-L2	11.5.1.1
	LUMINAIRE À GARNITURE – SANS PROTECTION THERMIQUE			11.7.1.11
2.27	SUITABLE FOR GROUND-MOUNTED RECESSED ONLY		S24-L2	11.5.1.1
	PEUT ÊTRE ENCASTRÉ DANS LE SOL			11.7.1.10
2.28	Reserved			11.8.1.14
	Réservé			
2.29	Reserved			
	Réservé			
2.30	Reserved			
	Réservé			
2.31	PLACE LIGHT SOURCE NO CLOSER THAN ___ mm ( ___ in) TO ANY COMBUSTIBLE SURFACE		S24-L1	19.1.2
	LAISSER UNE DISTANCE D'AU MOINS ___ mm ( ___ po) ENTRE LA SOURCE LUMINEUSE ET LA TOUTE SURFACE COMBUSTIBLE			
2.32	MAXIMUM AMBIENT OPERATING TEMPERATURE ___ °C	Verbatim	S24-L2	20.6.2 (MEX)
	TEMPÉRATURE AMBIANTE MAXIMALE DE FONCTIONNEMENT ___ °C			
Item	User maintenance	Text	Format	Clause reference
3.1	MAX ___ WATTS TYPE ___ or MAX ___ W TYPE ___	Verbatim	S48-L1 and S24-L1	7.1.2
	MAX ___ WATTS TYPE ___ ou MAX ___ W TYPE ___			7.2.5.2
3.2	MAX ___ WATTS TYPE ___ SHIELDED or MAX ___ W TYPE ___ SHIELDED	Verbatim	S48-L1 and S24-L1	7.2.6.1
	MAX ___ WATTS TYPE ___ AVEC ÉCRAN ou MAX ___ W TYPE ___ AVEC ÉCRAN			7.3.1.2
3.3	MAX ___ WATTS or MAX ___ W		S24-L1	11.8.2.1
	MAX ___ WATTS ou MAX ___ W			11.8.2.5

Table B.1 (CAN) Continued

Item	Installation instructions	Text	Format	Clause reference
3.4	MAX ___ AMPS or MAX ___ A		S24-L1	6.5.1
	MAX ___ AMPS ou MAX ___ A			
3.5	FUSE [identification] ___ AMPS		S24-L6	6.6.2
	FUSIBLE [identification] ___ AMPÈRES			
3.6	DISCONNECT POWER BEFORE SERVICING		S24-L1	6.4.1.4
	COUPER L'ALIMENTATION AVANT L'ENTRETIEN			7.3.2.3 9.5.3
3.7	AC ONLY		S24-L3	6.2.2
	C.A. SEULEMENT			
3.8	RELAMP WITH ___ WATTS TYPE ___ [lamp ANSI designation]		S24-L1	9.3.1
	UTILISER UNE AMPOULE DE REMPLACEMENT DE ___ WATTS, TYPE ___ [désignation ANSI de l'ampoule]			9.6.1 9.4.1.1
3.9	RELAMP WITH PAR LAMP ONLY		S24-L1	9.3.1
	REPLACER CETTE AMPOULE PAR UNE AMPOULE «PAR» UNIQUEMENT			
3.10	INSERT IN THIS LAMPHOLDER FIRST		S24-L1	7.3.2.1
	INTRODUIRE DANS CETTE DOUILLE D'ABORD			9.5.1
3.11	BLINKING LIGHT OF THIS THERMALLY PROTECTED LUMINAIRE MAY INDICATE OVERHEATING		S24-L1	11.8.1.10 11.8.1.11
	SI L'AMPOULE DE CE LUMINAIRE À PROTECTION THERMIQUE CLIGNOTE, CELA PEUT SIGNIFIER UNE SURCHAUFFE			
3.12	KEEP PROTECTIVE BARRIER IN PLACE or REPLACE REMOVABLE PARTS AFTER SERVICING		S24-L1	7.3.1.4 7.3.1.4 (USA) 9.6.5
	NE PAS ENLEVER L'ÉCRAN PROTECTEUR ou REPLACER LES PIÈCES AMOVIBLES APRÈS L'ENTRETIEN			
3.13	UV LIGHT SOURCE – KEEP PROTECTIVE BARRIER IN PLACE		S24-L1	9.6.6
	SOURCE DE RAYONS UV — NE PAS ENLEVER L'ÉCRAN PROTECTEUR			
3.14	USE MAX ___ WATTS TYPE ___ ONLY		S24-L1	9.6.2
	UTILISER UNIQUEMENT DES AMPOULES DE ___ W MAX, DE TYPE ___			
3.15	SEE OTHER (BACK) SIDE FOR RELAMPING INSTRUCTIONS		S24-L1	11.8.2.4
	VOIR L'AUTRE FACE (ARRIÈRE) POUR LES INSTRUCTIONS SUR LA FAÇON DE REMPLACER L'AMPOULE			
3.16	USE ___ VOLT LAMPS or USE ___ V LAMPS		S24-L1	9.6.2
	UTILISER DES AMPOULES DE ___ VOLTS ou UTILISER DES AMPOULES DE ___ VOLTS			



Table B.1 (CAN) Continued

Item	Installation instructions	Text	Format	Clause reference
3.17	<b>CAUTION – RISK OF FIRE</b>	Verbatim	S24-L1	7.1.2 7.1.2 (CAN) 7.2.5.2 7.2.5.2 (CAN) 7.2.6.1 7.2.6.1 (CAN) 7.3.1.2 7.3.1.2 (CAN) 9.3.1 10.8.1 10.8.1 (CAN) 11.8.2.1 11.8.2.1 (CAN) 11.8.2.5 11.8.2.5 (CAN)
	<b>ATTENTION – RISQUE D'INCENDIE</b>			
3.18	<b>CAUTION – RISK OF SHOCK</b>	Verbatim	S24-L1	6.4.1.4 6.4.1.4 (CAN) 7.3.2.1 7.3.2.1 (CAN) 7.3.2.3 7.3.2.3 (CAN) 9.5.1 9.5.1 (CAN) 9.5.3 9.5.3 (CAN)
	<b>ATTENTION – RISQUE DE CHOC</b>			
3.19	<b>CAUTION – RISK OF PERSONAL INJURY</b>	Verbatim	S24-L1	8.6.5 9.6.6 9.6.6 (CAN)
	<b>ATTENTION – RISQUE DE BLESSURE</b>			
3.20	<b>USE LAMP MARKED “SUITABLE FOR USE IN OPEN LUMINAIRES”</b>	Verbatim	S24-L1	7.3.1.2 8.6.5
	<b>UTILISER UNE LAMPE PORTANT LE MARQUAGE «CONVIENT AUX LUMINAIRES OUVERTS»</b>			
3.21	<b>USE ONLY ____ TYPE ____ WATTS LAMPS</b>		S24-L1	8.6.4
	<b>UTILISER EXCLUSIVEMENT DES LAMPES DE CLASSE ____ DE ____ WATTS</b>			
3.22	<b>CAUTION – TO AVOID UV EXPOSURE RISK, USE ANSI TYPE ( ) LAMP ONLY. DO NOT INSTALL A LAMP THAT REQUIRES UV FILTERING.</b> (The blank space shall be filled with “E or O” or “O”.)	Verbatim	S24-L1	9.4.1.1
	<b>ATTENTION. POUR ÉVITER LES RISQUES ASSOCIÉS À UNE EXPOSITION AUX RAYONS UV, UTILISER UNIQUEMENT DES LAMPES DE TYPE ANSI ( ). NE PAS UTILISER UNE LAMPE QUI NÉCESSITE UN FILTRE UV.</b> (Inscrire «E ou O» ou «O» dans l'espace.)			
3.23	<b>CAUTION – UV EXPOSURE RISK. USE MFR. ( ) TYPE NO. ( ) LAMP OR ANSI TYPE “E” OR “O ONLY.”</b> (The blank spaces shall be filled with the lamp manufacturer's name and lamp catalogue number).	Verbatim	S24-L1	9.4.2.1
	<b>ATTENTION. RISQUES D'EXPOSITION AUX RAYONS UV. UTILISER UNE LAMPE FABRIQUÉE PAR ( ) DE TYPE ( ) OU UNE LAMPE DE TYPE ANSI «E» OU «O».</b> (Le nom du fabricant et la référence au catalogue de la lampe doivent être inscrits dans les blancs.)			

Table B.1 (CAN) Continued

Item	Installation instructions	Text	Format	Clause reference
3.24	BALLAST DISCONNECT	Verbatim	S24-L6	8.9.1 (CAN)
	DÉBRANCHMENT DU BALLAST			
3.25	UNPLUG POWER SUPPLY CORD LOCATED AT _____		S24-L6	8.9.1 (CAN)
	or UNPLUG CONNECTOR LOCATED AT _____			
	DÉBRANCHER LE CORDON D'ALIMENTATION SITUÉ _____ ou DÉBRANCHER LE CONNECTEUR SITUÉ _____			
3.26	DANGER – RISK OF SHOCK – DISCONNECT POWER BEFORE INSTALLATION	Verbatim	S48-L5	8.10.2 (CAN)
	DANGER – RISQUE DE CHOC – COUPER L'ALIMENTATION AVANT L'INSTALLATION			
3.27	THIS LUMINAIRE IS PROVIDED WITH A FACTORY-INSTALLED EMERGENCY LIGHTING PACK AND MUST BE SERVICED BY A PERSON FAMILIAR WITH THE CONSTRUCTION AND OPERATION OF THE PRODUCT AND THE HAZARDS INVOLVED		S24-L6	8.9.4 (CAN)
	CE LUMINAIRE EST ÉQUIPÉ EN USINE D'UNE BATTERIE DE LUMIÈRES D'URGENCE ET SA RÉPARATION DOIT ÊTRE CONFIEE À UNE PERSONNE QUI CONNAÎT BIEN LE PRODUIT ET SON FONCTIONNEMENT AINSI QUE LES RISQUES INHÉRENTS			
3.28	DANGER – RISK OF SHOCK DISCONNECT ALL POWER AND DISABLE THE BATTERY PACK POWER BEFORE SERVICING BALLAST REPLACEMENT REQUIRES RECONNECTION OF WIRES THAT MAY BE ENERGIZED		S48-L6 and S24-L6	8.9.4 (CAN)
	DANGER – RISQUE DE CHOC COUPER L'ALIMENTATION ET NEUTRALISER LA BATTERIE D'ACCUMULATEURS AVANT DE PROCÉDER À LA RÉPARATION DU BALLAST LE REMPLACEMENT DU BALLAST NÉCESSITE LA RECONNEXION DE CONDUCTEURS QUI PEUVENT ÊTRE SOUS TENSION			
ITEM	Miscellaneous markings	Text	Format	Clause reference
4.1	MANUFACTURER'S IDENTIFICATION		S16-L2	8.6.2
	IDENTIFICATION DU FABRICANT			11.8.1.6
				11.8.4.1
				20.2.1
				20.2.4
4.2	CATALOGUE NUMBER OR CAT. NO. OR SIMILAR PRODUCT IDENTIFICATION		S16-L2	8.6.2
	RÉFÉRENCE AU CATALOGUE OU RÉF. CAT. OU IDENTIFICATION SIMILAIRE DU PRODUIT			11.8.1.6
				11.8.4.1
				20.2.2

Table B.1 (CAN) Continued

Item	Installation instructions	Text	Format	Clause reference
4.3	DATE MARKING OR CODED FORM CONSISTING OF, AT LEAST, MONTH AND YEAR		S16-L2	20.2.1
	MARQUAGE DE LA DATE OU MARQUAGE CHIFFRÉ INCLUANT AU MOINS LE MOIS ET L'ANNÉE			
4.4	<b>G or GR or GRD or GND or GRND or GROUND or </b>		S24-L3	6.14.2.9 6.14.2.12
	<b>G ou GR ou GRD ou GRND ou GROUND ou </b>			
4.5	TO PREVENT ELECTRIC SHOCK, MATCH WIDE BLADE OF PLUG TO WIDE SLOT		S16-L5	6.10.4
	POUR EVITER LES CHOCS ELECTRIQUES, INTRODUIRE LA LAME LA PLUS LARGE DE LA FICHE DANS LA FENTE LA PLUS LARGE			
4.6	FACTORY IDENTIFICATION		S16-L2	20.2.1
	IDENTIFICATION DE L'USINE			
4.7	<b>THIS LUMINAIRE IS DESIGNED FOR USE WITH GERMICIDAL LAMPS AND MUST BE INSTALLED IN COMPLIANCE WITH COMPETENT TECHNICAL DIRECTIONS TO PREVENT THE USER'S EYE AND BARE SKIN FROM EXPOSURE TO HARMFUL UV RADIATION.</b>	Verbatim	S24-L1	8.6.5
	<b>CE LUMINAIRE EST CONÇU POUR ÊTRE UTILISÉ AVEC DES LAMPES GERMICIDES ET DOIT ÊTRE INSTALLÉ EN STRICTE CONFORMITÉ AVEC LES INSTRUCTIONS AFIN D'ÉVITER QUE LES YEUX OU LA PEAU DE L'UTILISATEUR NE SOIENT EXPOSÉS AUX EFFETS NÉFASTES DES RAYONS UV</b>			

NOTE: The text shown in the table represents the actual minimum size and typestyle required.

**Annex C (MEX) (normative)**  
 Markings – Spanish translations

**Table C.1 (MEX)**  
**Markings — Spanish Translations**

(See Table 20.1.1.)

Item	Installation instructions	Text	Format	Clause reference
1.1	CONDUCTORES DE ALIMENTACIÓN ___ °C Min	Verbatim	S24-L3 and S32-L4	6.7.2.4 6.15.1.5 6.15.1.5 (CAN) 7.2.3.2 7.2.3.3 7.2.3.4 7.2.3.5 8.5.2 10.6.9 (USA) 10.6.9 (CAN) 10.6.10 (CAN) 11.8.1.2 12.3.4.1
1.2	CONECTAR A CIRCUITO DERIVADO CON CORRIENTE NOMINAL MAXIMA		S24-L3	11.8.1.8 11.8.1.9
1.3	___ VOLTS ___ AMPERS ___ WATTS ___ HERTZ o ___ V ___ A ___ W ___ Hz		S24-L3	20.2.3
1.4	___ VOLTS ___ HERTZ o ___ V ___ Hz		S24-L3	6.2.2 7.1.4
1.5	N o NEUTRO o W o BLANCO		S24-L3	6.10.1
1.6	APTO PARA FUNCIONAR EN AMBIENTES HASTA ___ °C		S24-L2	12.4.3.1
1.7	APTO PARA USAR COMO CANALETA		S24-L3	5.20.3
1.8	PIEZA ENSAMBLADA [número de catálogo] SOLO CON LA PIEZA [número de catálogo]		S24-L4	5.2.3 20.2.4
1.9	USAR SOLO CON GUARNICIONES [núm. de catálogo] [fabricante]		S24-L2	11.8.1.7
1.10	USAR SOLO CON LUMINARIA [núm. de catálogo] [fabricante]		S24-L2	11.7.1.8 (USA) 12.2.4.4 (USA)
1.11	USAR CON DIFUSOR DE LUZ HOMOLOGADO/ LISTADO [número de pieza]		S24-L2	12.2.4.3 (USA)
1.12	SISTEMA DE GABLEADO EXCLUSIVO [nombre, número de pieza, marca de precaución]		S24-L2	6.15.1.1
1.13	NO INSTALAR AISLAMIENTO A MENOS DE 76 MM DE CUALQUIER PARTE DE LUMINARIE		S24-L2	11.8.1.10 11.8.4.1
1.14	LA BARRERA DE VAPOR DESE SER APROPIADA PARA 90 °C		S24-L2	11.8.1.12 11.8.1.12 (USA)
1.15	APTO PARA USAR CON CIRCULACION DE AIRE		S24-L2	12.2.4.1
1.16	UNICAMENTE AIRE DE VENTILACION O EN FRIADO		S24-L2	12.2.4.2
1.17	INSTALAR SOLO EN CIRCULACION DE AIRE AMBIENTAL SIN DUCTOS NI PLENOS DONDE SE PROVEA UN SISTEMA COMPLETE DE CABLEADO METALICO ENCERRADO		S24-L3	12.2.4.7
1.18	Reserved			

Table C.1 (MEX) Continued

Item	Installation instructions	Text	Format	Clause reference
1.19	INSTALAR CON SEPARACION MINIMA ENTRE (a) CENTRO A CENTRO DE LUMINARIOS ADYACENTES: ___mm (___in) (b) PARTE SUPERIOR DE LUMINARIO Y MIENDRO SUPERIOR DE LA CONSTRUCCION (c) CENTRO DE LUMINARIO Y MIENDRO LATERAL LA CONSTRUCCION		S24-L2	11.7.1.11 11.8.3.1 12.3.4.2
1.20	INSTALAR FOTOCONTROL O CLAVIJA DE CORTOCIRCUITO		S24-L2	6.4.1.5
1.21	ESTE LUMINARIO DEBE ESTAR O SOPORTADO INDEPENDIEMENTE DE UNA CAJA TOMACORRIENTE		S24-L2	10.2.5 10.2.5 (USA)
1.22	EXCLUSIVAMENTE PARA COLGAR CON CADENA O GANCHO		S24-L2	10.8.4
1.23	LIMITAR LA AMPLITUD DEL AJUSTE A [instruccion]		S24-L1	13.4.9.2
1.24	(EAU) PARA USO EXCLUSIVO CON LUMINAIRIO CON SOPORTE (CAN) PARA LOS CONDUCTORES DE ALIMENTACION		S24-L2	10.3.9
1.25	EMPUJAR LOS CONDUCTORES DENTRO DE LA CAJA DE DERIVACION		S24-L2	7.2.7.2
1.26	PARA USAR EXCLUSIVAMENTE EN INSTALACIONES CLASIFICADAS CONTRA INCENDIOS		S24-L2	11.4.7 11.8.5.2
1.27	PARA VOLTS-AMPERS DE LINEA, MULTIPLICAR LA POTENCIA TOTAL DE LAS LAMPARAS POR 1,5		S24-L3	8.6.1
1.28	PARA VOLTS-AMPERS DE LINEA, MULTIPLICAR LA POTENCIA TOTAL DE LAS LAMPARAS POR 2,5		S24-L3	8.6.1
1.29	PARA VOLTS-AMPERS DE LINEA MULTIPLICAR EL TOTAL DE TODAS LAS LAMPARAS EN PULGADAS POR _____		S24-L3	8.6.1
1.30	UTILIZAR BALASTRO TÉRMICAMENTE PROTEGIDO PARA LÁMPARAS TIPO _____		S24-L2	8.6.3
1.31	ESTE PRODUCTOR DEBE SER INSTALADO SEGUN EL CODIGO DE INSTALACION APLICABLE POR UNA PERSONA QUE CONOZCA LA CONSTUSSION Y EL FUNCIONAMIENTO DEL PRODUCTO Y LOS RIESGOS QUE SUPONE		S24-L4	10.8.1 20.5.1
1.32	CONSULTAR A UN ELECTRICISTA CALIFICADO PARA ASEGURAR LA ELECCION DEL CONDUCTOR DE CIRCUITO DERIVADO		S24-L4	10.8.1 10.8.1 (CAN)

Table C.1 (MEX) Continued

Item	Installation instructions	Text	Format	Clause reference
1.33	INSTRUCCIONES DE INSTALACION O MONTAJE		S16-L5	5.1.2 5.2.2 5.15.2.4 5.15.2.5 6.14.1.3 6.14.2.13 6.15.1.1 6.15.1.3 7.3.1.2 10.2.5 10.2.5 (USA) 10.2.6 10.6.7 (USA) 11.1.4 11.8.4.1 11.8.5.1 13.4.9.3
1.34	SECCION RUSTICA PARA USARSE EN SECCION ACABADA		S16-L2	11.8.1.5
1.35	SECCION ACABADA PARA USARSE EN SECCION RUSTICA		S16-L2	11.8.4.1
1.36	SECCION RUSTICA ___ PARA LUMINARIA EN POTRABLE		S16-L2	11.8.4.1
1.37	PARA USO SOLO CABLE, NO PARA COLGAR		S24-L3	11.3.3
1.38	TIPO-IC CON REFLECTORES/SECCIONES TERMINADAS: AA BB CC [etc.] TIPO-NO IC CON REFLECTORES/SECCIONES TERMINADAS: AA BB CC [etc.]		S24-L3	11.8.4.1
1.39	PARA UTILIZARSE ÚNICAMENTE EN VIVIENDAS SENCILLAS Y DÚPLEX NO PARA UTILIZARSE EN ESPACIOS CON MANEJO DE AIRE AMBIENTAL		S24-L3	11.8.5.2
1.40	NUMERO MAXIMO DE CONDUCTORES TOMANO ___ mm <sup>2</sup> (___ AWG) A TRAVES DEL CIRCUITO DERIVADO ADEWADO PARA ___ °C PERMITIDO EN CAJA		S24-L3	11.3.3 14.10.3 14.11.2
1.41	USAR BALASTRO PARA LÁMPARA TIPO _____ DE _____ WATTS		S24-L2	6.7.2.3
1.42	ESTE LUMINARIO SE PROPORCIONA CON UNA BATERÍA DE LUZ DE EMERGENCIA INSTALADA EN FÁBRICA		S24-L2	8.7
1.43	PARA CONEXIONES DE ALIMENTACION UTILICE CONDUCTORES ADECUADOS PARA: XX °C	Verbatim	S24-L3	20.6.2 (MEX)
Item	Mounting locations	Text	Format	Clause reference
2.1	LUGARES SECOS EXCLUSIVAMENTE	Verbatim	S24-L2	13.1.2
2.2	APTO PARA LUGARES HUMEDOS	Verbatim	S24-L2	13.1.2 13.3.1.1
2.3	APTO PARA LUGARES MOJADOS	Verbatim	S24-L2	13.1.2 13.4.9.1
2.4	EXCLUSIVAMENTE PARA USO EXTERNO	Verbatim	S24-L2	8.2.1

Table C.1 (MEX) Continued on Next Page

Table C.1 (MEX) Continued

Item	Installation instructions	Text	Format	Clause reference
2.5	<b>NO PARA USO EN VIVIENDAS</b>	Verbatim	S24-L3	6.7.1.1 6.15.1.4 7.2.3.2 10.6.9 (USA) 10.6.9 (CAN) 10.6.10 (CAN) 11.8.1.2
2.6	<b>EXCLUSIVAMENTE PARA SUPERFICIES NO COMBUSTIBLES</b>	Verbatim	S24-L3	10.4.9 10.8.3 11.7.1.10 20.4.2
2.7	<b>ACCESO REQUERIDO SOBRE EL TECHO</b>	Verbatim	S24-L2	11.6.1.1 11.8.1.4
2.8	<b>ACCESO REQUERIDO POR DETRAS DE LA PARED</b>	Verbatim	S24-L2	11.8.1.4
2.9	<b>SOLO PARA PLENO DE TECHO NO COMBUSTIBLE</b>		S24-L2	12.2.4.5
2.10	<b>EXCLUSIVAMENTE PARA FIJACION EN MURO</b>	Verbatim	S24-L2	7.2.7.1 10.7.2 14.2.1
2.11	<b>EXCLUSIVAMENTE PARA FIJACION EN TECHO CUBIERTO</b>		S24-L2	13.4.8.3 13.4.8.6
2.12	<b>APTO PARA FIJACION BAJO ARMARIO</b>	Verbatim	S24-L2	10.8.2 (USA)
2.13	<b>ORIENTACION DE MONTAJE [como “este lado arriba”]</b>		S24-L2	20.4.1
2.14	<b>APTO PARA FIJACION EMPOTRADA EN EL SUELO</b>		S24-L2	13.4.8.13
2.15	<b>Reserved</b>			
2.16	<b>APTO PARA FIJACION EN HILERAS</b>		S24-L2	5.19.1
2.17	<b>INSTALAR EN EDIFICIOS DE CONSTRUCCION CONTRA INCENDIOS – FIJAR SOBRE MATERIAL NO COMBUSTIBLE</b>		S24-L2	11.8.1.3
2.18	<b>APTO PARA FIJACION A 1,2 m (4 ft) DEL PISO</b>		S24-L2	13.4.8.8 13.4.8.10 13.4.8.12
2.19	<b>FIJAR MINIMO A 1,2 m (4 ft) SOBRE LA SUPERFICIE DE COCIMIENTO</b>		S24-L5	12.3.4.1
2.20	<b>PARA USO EXCLUSIVO EN CONCRETO</b>		S24-L2	11.7.1.9 11.8.1.14
2.21	<b>APTO PARA USAR EN CONCRETO COLADO</b>		S24-L2	11.4.6
2.22	<b>APTO PARA USAR DENTRO DE UNA CAMPANA DE COCINA</b>		S24-L2	12.3.4.1
2.23	<b>TIPO IC</b>		S24-L3	11.5.1.1 11.8.1.11 11.8.1.13 11.8.4.1
2.24	<b>CON PROTECCION INHERENTE</b>		S24-L3	11.5.1.1 11.8.1.13
2.25	<b>EXCLUSIVAMENTE PARA FIJACION EN TECHO ABIERTO</b>		S24-L1	11.7.1.12
2.26	<b>LUMINARIA DE CUBIERTA – SIN PROTECCION TERMICA</b>		S24-L2	11.5.1.1 11.7.1.11
2.27	<b>APTO SOLO PARA FIJACION EMPOTRADO EN EL SUELO</b>		S24-L2	11.5.1.1 11.7.1.10 11.8.1.14

Table C.1 (MEX) Continued on Next Page


Table C.1 (MEX) Continued

Item	Installation instructions	Text	Format	Clause reference
2.28	Reserved			
2.29	Reserved			
2.30	Reserved			
2.31	COLOCAR LA FUENTE DE LUZ A UNA DISTANCIA NO MENOR DE ___ mm DE CUALQUIER SUPERFICIE COMBUSTIBLE		S24-L1	19.1.2
2.32	TEMPERATURA AMBIENTE MAXIMA DE OPERACION: XX °C	Verbatim	S24-L2	20.6.2 (MEX)
Item	User maintenance	Text	Format	Clause reference
3.1	MAX ___ WATTS TIPO ___ O MAX ___ W TIPO ___	Verbatim	S48-L1 and S24-L1	7.1.2 7.2.5.2 7.2.6.1 7.3.1.2 11.8.2.1 11.8.2.5
3.2	MAX ___ WATTS TIPO ___ PROTEGIDO O MAX ___ W TIPO ___ PROTEGIDO	Verbatim	S48-L1 and S24-L1	7.3.1.2
3.3	MAX ___ WATTS O MAX ___ W		S24-L1	6.5.1
3.4	MAX ___ AMPERS O MAX ___ A		S24-L1	6.5.1
3.5	FUSIBLE [identificacion] ___ A		S24-L6	6.6.2
3.6	DESCONECTAR LA ENERGIA ANTES DEL SERVICIO		S24-L1	6.4.1.4 7.3.2.3 9.5.3
3.7	EXCLUSIVAMENTE PARA CA		S24-L3	6.2.2
3.8	REEMPLAZAR POR LAMPARA DE ___ WATTS TIPO ___ [designacion de la lampara]		S24-L1	9.3.1 9.6.1 9.6.1 (MEX)
3.9	CAMBIAR ÚNICAMENTE POR UNA LÁMPARA IGUAL		S24-L1	9.3.1
3.10	INSERTAR PRIMERO EN ESTE PORTALAMPARAS		S24-L1	7.3.2.1 9.5.1
3.11	LA LUZ INTERMITENTE DE ESTE LUMINARIO CON PROTECCION TERMICA PUEDA INDICAR RECALENTAMIENTO		S24-L1	11.8.1.10 11.8.1.11
3.12	MANTENER EN SU SITIO LA BARRERA PROTECTORA O CAMBIAR LAS PIEZAS DESMONTABLES DESPUES DEL SERVICIO		S24-L1	7.3.1.4 7.3.1.4 (USA) 9.6.5
3.13	FUENTE DE LUZ UV — NO RETIRAR LA BARRERA PROTECTORA		S24-L1	9.6.6
3.14	USAR EXCLUSIVAMENTE MAX ___ WATTS TIPO ___		S24-L1	9.6.2
3.15	VER AL DORSO INSTRUCCIONES PARA CAMBIAR LA LAMPARA		S24-L1	11.8.2.4
3.16	USAR LAMPARAS DE ___ VOLTS o USAR LAMPARAS DE ___ V		S24-L1	9.6.2

Table C.1 (MEX) Continued

Item	Installation instructions	Text	Format	Clause reference
3.17	<b>PRECAUCION – RIESGO DE INCENDIO</b>	Verbatim	S24-L1	7.1.2 7.1.2 (CAN) 7.2.5.2 7.2.5.2 (CAN) 7.2.6.1 7.2.6.1 (CAN) 7.3.1.2 7.3.1.2 (CAN) 9.3.1 10.8.1 10.8.1 (CAN) 11.8.2.1 11.8.2.1 (CAN) 11.8.2.5 11.8.2.5 (CAN)
3.18	<b>PRECAUCION – RIESGO DE CHOQUE ELECTRICO</b>	Verbatim	S24-L1	6.4.1.4 6.4.1.4 (CAN) 7.3.2.1 7.3.2.1 (CAN) 7.3.2.3 7.3.2.3 (CAN) 9.5.1 9.5.1 (CAN) 9.5.3 9.5.3 (CAN)
3.19	<b>PRECAUCION – RIESGO DE DANO PERSONAL</b>	Verbatim	S24-L1	8.6.5 9.6.6 9.6.6 (CAN)
3.20	<b>USAR LÁMPARAS MARCADAS “ADECUADA PARA USARSE EN LUMINARIOS ABIERTOS”</b>	Verbatim	S24-L1	7.3.1.2
3.21	<b>USAR SÓLO CON LÁMPARAS TIPO ____ DE ____ WATTS</b>		S24-L1	8.6.4
3.22	<b>PRECAUCIÓN – PARA EVITAR RIESGO DE EXPOSICIÓN A UV, UTILIZAR ÚNICAMENTE LÁMPARA TIPO ANSI ( ). NO INSTALAR UNA LÁMPARA QUE REQUIERA FILTRO UV.</b> (El espacio en blanco debe llenarse con “E u O” u “O.”)	Verbatim	S24-L1	9.4.1.1 (MEX)
3.23	<b>PRECAUCIÓN — RIESGO DE EXPOSICIÓN A UV. UTILIZAR ÚNICAMENTE LÁMPARA FAB ([mldr ].) No. DE TIPO ([mldr ].) O TIPO ANSI “E” U “O.”</b> (El espacio en blanco debe llenarse con “E u O” u “O.”)	Verbatim	S24-L1	9.4.2.1
ITEM	Miscellaneous markings	Text	Format	Clause reference
4.1	IDENTIFICACION DEL FABRICANTE		S16-L2	8.6.2 11.8.1.6 11.8.4.1 20.2.1 20.2.4
4.2	NUMERO DE CATALOGO O NUM. DE CAT. O IDENTIFICACION SIMILAR DEL PRODUCTO		S16-L2	8.6.2 11.8.1.6 11.8.4.1 20.2.2
4.3	FECHA DE FABRICACION O FORMA CODIFICADA, INDICANDO POR LO MENOS MES Y AÑO		S16-L2	20.2.1

Table C.1 (MEX) Continued

Item	Installation instructions	Text	Format	Clause reference
4.4	G o GR o GRD o GND o GRND o GROUND o 		S24-L3	6.14.2.9 6.14.2.12
4.5	PARA EVITAR CHOQUES ELECTRICOS, HACER COINCIDIR LA PATA ANCHA DE LA CLAVIJA CON LA RANURA ANCHA		S16-L5	6.10.4
4.6	IDENTIFICACION DE FABRICA (EUA)		S16-L2	20.2.1
4.7	ESTE LUMINARIO SE DISEÑA PARA UTILIZARSE CON LÁMPARAS GERMICIDAS Y DEBE INSTALARSE EN CONFORMIDAD CON DIRECCIONES TÉCNICAS COMPETENTES PARA PREVENIR LA EXPOSICIÓN A LA RADIACIÓN DE UV PELIGROSA DE LOS OJOS Y PIEL DESNUDA DEL USUARIO.	Verbatim	S24-L1	8.6.5
NOTE: The text shown in the table represents the actual minimum size and typestyle required.				

## **Annex D (normative)**

### Pictograms

D.1 A pictogram used as a substitute for the corresponding text of Table 20.1.1 shall provide a consistent representation of the information and shall be the subject of special investigation.

D.2 The recommended format of a pictogram including the text, as shown in Figure D.1, is a 19 mm (0.75 in) square for presentation. The recommended minimum size of a pictogram is a 9.5 mm (0.375 in) square, as shown in Figure D.2. See Figure D.3 for pictogram proportions.

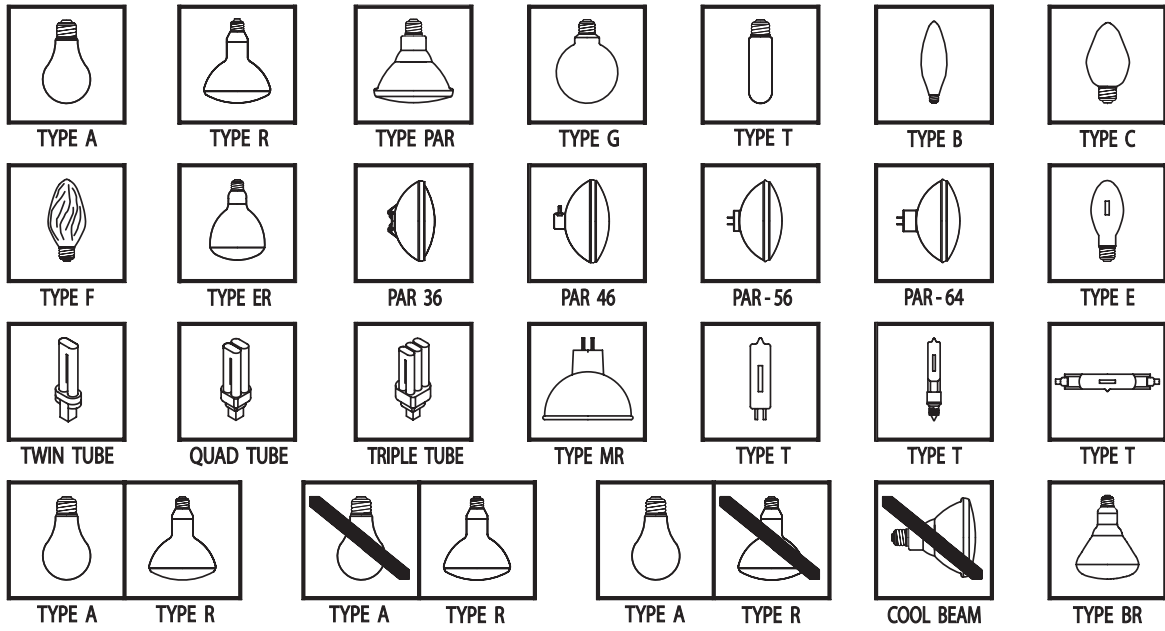
D.3 Current practice allows the pictogram of a lamp shape to be used without the border and text.

D.4 Figure D.4 is a pictogram for an open luminaire.

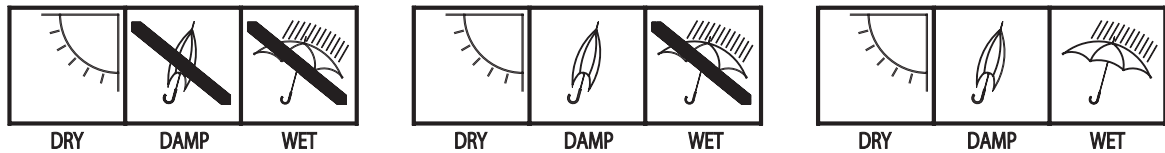
**Figure D.1**  
**Pictogram format**

(See Clause D.2.)

**LAMP TYPE**



**ENVIRONMENT**



**LOCATION**



**ORIENTATION**



**CAUTION**



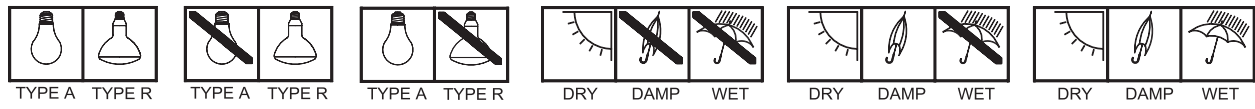
**MAX**

is a symbol that is a minimum of 4.8 mm (0.188 in) high and 15 mm (0.8 in) wide with a character stroke width of 1 mm (0.40 in). Uppercase typestyle Univers Bold 19 provides the correct size, character spacing, and character stroke width.

NOTE Pictogram format frame shown is a 16 mm (0.625 in) square.

**Figure D.2**  
**Pictogram minimum size**

(See Clause D.2.)

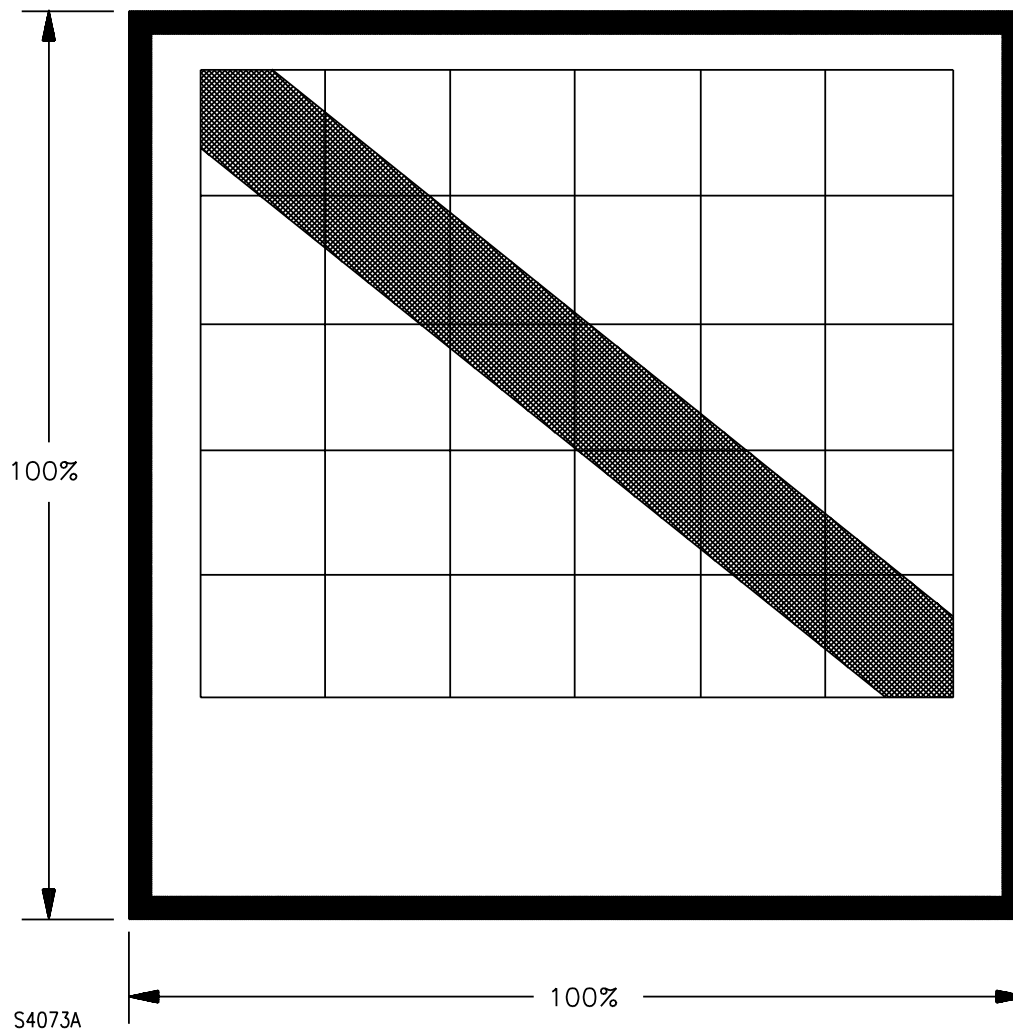


S3845

**NOTE** Pictogram format frame shown is a 9.5 mm (0.375 in) square.

**Figure D.3**  
**Pictogram proportions**

(See Clause D.2.)

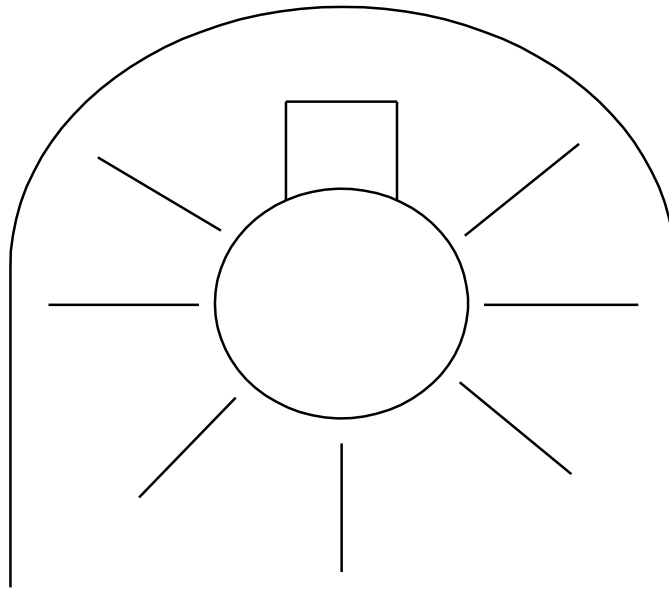


NOTE Pictogram proportions shall be as follows:

- (a) border width, 2.5 percent;
- (b) graphic area 6 x 5 grid, 14 percent;
- (c) text height, 11.5 percent;
- (d) negative slash width, 11.5 percent;
- (e) top and bottom inside border, 4 percent; and
- (f) side inside border, 5.5 percent.

**Figure D.4**  
**Pictogram for an open luminaire**

(See Clauses 7.3.1.2 and D.4.)



S4636

**Annex E (informative)**  
Metric Conversion Information

**Table E.1**  
**Metric conversion multipliers**

SI unit	SI symbol	Multiplier (SI x Mult = Imp)	Imperial unit	Imperial symbol
gram	g	0.0022	pound (weight)	lb
kilogram	kg	2.2046	pound (weight)	lb
millimeter	mm	0.0394	inch	in
meter	m	3.2808	foot	ft
square millimeter	mm <sup>2</sup>	0.00155	square inch	in <sup>2</sup>
square centimeter	cm <sup>2</sup>	0.1550	square inch	in <sup>2</sup>
cubic centimeter	cm <sup>3</sup>	0.0610	cubic inch	in <sup>3</sup>
square meter	m <sup>2</sup>	10.7639	square foot	ft <sup>2</sup>
cubic meter	m <sup>3</sup>	35.3147	cubic foot	ft <sup>3</sup>
Newton	N	0.2248	pound-force (force)	lb
Newton meter	N·m	0.7376	pound-force foot (torque)	lb·ft
Newton meter	N·m	8.8512	pound-force inch (torque)	lb·in
Joule	J	0.7376	foot pound-force (energy)	ft·lb
kilopascal	kPa	0.1450	pounds per square inch	psi
Rsi (thermal resistance)	Rsi m <sup>2</sup> · C°/W	5.6783	R (thermal resistance)	R ft <sup>2</sup> · F° · h/BTU
Gram/meter <sup>2</sup>	g/m <sup>2</sup>	0.00328	ounces/foot <sup>2</sup>	oz/ft <sup>2</sup>

**NOTE** The values in this Standard are specified in SI (metric) units and the Imperial units given in parenthesis are provided for information only.

## Annex F (CAN) (normative)

### Printed Circuit Boards

#### F.1 Special terminology

The following definitions apply:

**Insulation, basic** – insulation to provide basic protection against electric shock.

**Insulation, double** – insulation comprising both basic insulation and supplementary insulation.

**Insulation, functional** – insulation that is necessary only for the correct operation of the equipment.

**Insulation, reinforced** – a single insulation system which provides a degree of protection against electric shock equivalent to double insulation under the conditions specified in this Standard.

**Insulation, supplementary** – independent insulation applied in addition to basic insulation in order to reduce the risk of electric shock in the event of a failure of the basic insulation.

#### F.2 General

F.2.1 A printed circuit board that is coated with a conformal coating or other coating shall be capable of withstanding the printed circuit board coatings test of Clause F.3. The coating shall be applied to the printed circuit board before installation of electrical components.

F.2.2 Printed circuit boards, conformal coating, and components shall comply with the vertical burning test of Clause 16.26 or the needle-flame test of Clause 16.27, for a flammability classification of at least V-2.

F.2.3 Components, such as IC packages, transistors, opto-isolators, and capacitors, shall be exempt from the flammability classification V-2 requirement of Clause F.2.2, if they are mounted on material having a flammability classification of at least V-1.

F.2.4 Spacings between uninsulated live parts of a circuit containing a solid state component, such as a rectifier, resistor, capacitor, or transistor shall:

- (a) be not less than the values shown in Table F.2.1;
- (b) withstand the insulation resistance test of Clause F.3.3; or
- (c) withstand the fault conditions test of Clause F.3.4.

**Table F.2.1**  
**Minimum spacings on printed circuit boards**

(See Clauses F.2.4 and F.3.4.2.)

To be classified as functional, basic, or supplementary insulation					To be classified as reinforced insulation			
Operating voltage rms	Uncoated		Conformal coated		Uncoated		Conformal coated	
	mm	(in)	mm	(in)	Mm	(in)	mm	(in)
0 – 50	0.6	(0.024)	0.1	(0.004)	1.2	(0.048)	0.2	(0.008)
51 – 100	0.7	(0.028)	0.2	(0.008)	1.4	(0.055)	0.4	(0.016)
101 – 150	0.8	(0.032)	0.3	(0.012)	1.6	(0.063)	0.6	(0.024)
151 – 200	1.0	(0.039)	0.4	(0.016)	2.0	(0.079)	0.8	(0.032)
201 – 250	1.3	(0.051)	0.6	(0.024)	2.6	(0.102)	1.2	(0.048)
251 – 300	1.6	(0.063)	0.8	(0.032)	3.2	(0.126)	1.6	(0.063)
301 – 400	2.0	(0.079)	1.0	(0.039)	4.0	(0.157)	2.0	(0.079)
401 – 500	2.6	(0.102)	1.3	(0.051)	5.2	(0.205)	2.6	(0.102)
501 – 630	3.6	(0.142)	1.8	(0.071)	7.2	(0.238)	3.6	(0.142)
631 – 800	3.8	(0.150)	2.4	(0.094)	7.6	(0.299)	4.8	(0.189)
801 – 1000	4.0	(0.157)	2.8	(0.110)	8.0	(0.315)	5.6	(0.220)
1001 – 1250	4.2	(0.165)	3.4	(0.134)	8.4	(0.331)	6.8	(0.268)
1251 – 1600	4.6	(0.181)	4.1	(0.161)	9.2	0.362	8.2	(0.323)
1601 – 2000	5.0	(0.197)	5.0	(0.197)	10.0	(0.394)	10.0	(0.394)
2001 – 2500	6.3	(0.248)	6.3	(0.248)	12.6	(0.496)	12/6	(0.496)

### F.3 Printed circuit board coatings

#### F.3.1 Dielectric strength

F.3.1.1 A specimen shall be conditioned by flexing it 4 times so that the midpoint of the board is displaced from the line joining the two shortest edges of the board a distance equal to 5 percent of the length of the printed circuit board, to simulate conditions that can be expected under normal handling.

F.3.1.2 The following test voltages shall be applied for 1 min, without breakdown, between adjacent printed circuit conductors where the reduced spacings exist:

- (a) 500 V for a circuit operating at 50 V or less; and
- (b) 1000 V plus twice the working voltage for a circuit operating at more than 50 V.

F.3.1.3 The same specimen shall be conditioned by maintaining it for 96 h at  $90 \pm 1$  °C, and then shall be subjected to the test specified in Clause F.3.1.2.

F.3.1.4 The same specimen shall be conditioned at  $23 \pm 1$  °C and  $96 \pm 2$  percent relative humidity for 96 h and then shall be subjected to the test specified in Clause F.3.1.2.

### F.3.2 Adhesion

F.3.2.1 The same specimen used for the dielectric strength test shall be investigated for adhesion of the coating to the board by pressing a strip of pressure-sensitive celluloid tape 12.7 mm (0.5 in) wide and 50 mm (2 in) long firmly onto the surface of a conductor pattern, eliminating all air bubbles, and then removing it by manually gripping one end and rapidly pulling it off at an angle of approximately 90 degrees. There shall be no evidence of removal of the protective coating or the conductor pattern as shown by the pattern particles adhering to the tape. If slivers of metal adhere to the tape, it can be evidence of overheating and of unacceptable bond strength. The tape used for this test shall have an adhesion of  $400 \pm 60$  N/m ( $27 \pm 4$  lb/ft), as determined by ASTM D 1000.

F.3.2.2 Using a specimen as described in Clause F.3.2.1 and the apparatus of Clause F.3.2.5, scratches shall be made across 5 pairs of conducting parts and the intervening separations at points where the separations will be subjected to the maximum potential gradient during the tests.

F.3.2.3 Scratches shall be made by drawing the pin along the surface in a plane perpendicular to the conductor edges at a speed of  $20 \pm 5$  mm/s ( $0.8 \pm 0.2$  in/s), as shown in Figure F.2.1. The pin shall be so loaded that the force exerted along its axis is  $10 \pm 0.5$  N ( $2.25 \pm 0.1$  lb) from the edge of the specimen.

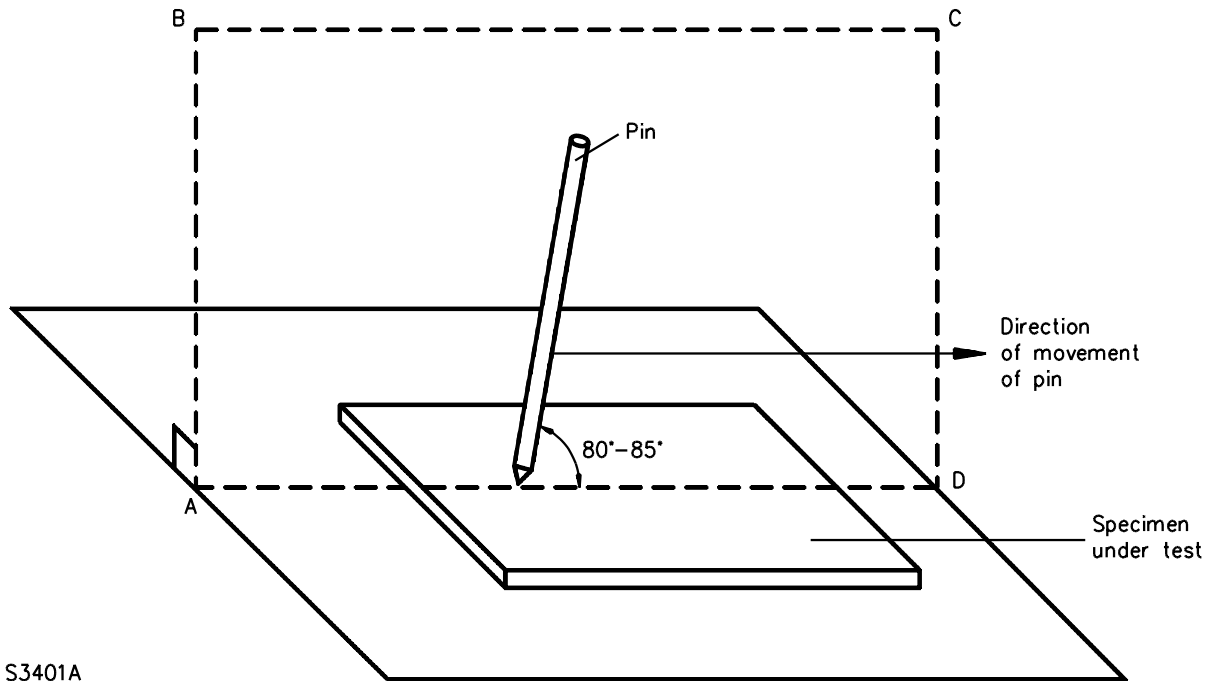
F.3.2.4 After this test, the coating layer shall neither have loosened nor have been pierced, and the specimen shall withstand a dielectric strength test between conductors, as specified in Clause F.3.1.

#### F.3.2.5 Abrasion resistance test apparatus

The test apparatus shall be as shown in Figure F.2.1. The pin shall be made of hardened steel. The end of the pin shall have the form of a cone with a top angle of 40 degree, and its tip shall be rounded and polished, with a radius of  $0.25 \pm 0.02$  mm ( $0.010 \pm 0.001$  in).

**Figure F.2.1**  
**Abrasion resistance test apparatus for PCB conformal coatings**

(See Clauses F.3.2.3 and F.3.2.5.)



S3401A

**F.3.3 Insulation resistance test voltage**

Functional, basic, supplementary, double, and reinforced insulation shall withstand the test voltages shown in Table F.2.2, in accordance with the dielectric voltage-withstand test of Clause F.3.1.

**Table F.2.2**  
**Insulation resistance test voltages**

(See Clause F.3.3.)

<b>Printed circuit boards with an earth ground conductive part as the protective means</b>				
Maximum operating voltage (MOV)	0 – 50	51 – 130	131 – 250	251 – 1000
Basic insulation between the supply conductors and grounded metal parts	500	1000	1500	Twice MOV + 1000
Basic insulation between the supply circuit conductors and the isolated secondary circuits	500	1000	1500	Twice MOV + 1000
Basic insulation between the isolated secondary circuits and grounded metal parts	500	500	500	500
Functional insulation between the isolated secondary circuits	500	500	500	500
<b>Printed circuit boards provided with double or reinforced insulation</b>				
Maximum operating voltage (MOV)	0 – 50	51 – 130	131 – 250	251 – 1000
Basic insulation between the supply-circuit conductors and the isolated circuits	500	2500	3000	3000
Basic insulation between the supply-circuit conductors and internal intermediate metal parts	500	1000	1500	Twice MOV + 1000
Supplementary insulation	500	1500	1500	Twice MOV + 1000

Table F.2.2 Continued on Next Page

**Table F.2.2 Continued**

Functional insulation between the isolated secondary circuits	500	500	500	500
Double or reinforced insulation between uninsulated live parts of the supply circuit and ungrounded accessible enclosure surfaces	500	2500	3000	3000

F.3.4.1 The printed circuit board with components shall be subjected to the fault conditions test of Clause F.3.4.2.

F.3.4.2 Each of the fault conditions of Items (a) and (b), as well as any other associated fault conditions that may arise as logical consequences, shall be applied in turn. Only one component at a time shall be subjected to any one fault condition:

(a) single-fault conditions representing the failure of components such as, but not limited to, semiconductor devices, capacitors, resistors, inductors, transformers, and protective devices. The failure mode shall be chosen to represent the manner in which the component is known to fail; and

(b) opening or bridging points in the circuit where the spacing between the uninsulated live parts of a rectifier, resistor, capacitor, transistor, or other solid state device is less than the values shown in Table F.2.1 and where such a fault condition can impair safety.